



NICE3000^{new}
Integrated Elevator Controller
User Manual V1.0



NICE3000^{new}

Integrated Elevator Controller

Suzhou MONARCH Control Technology Co., Ltd.

Data code:19010185

Preface

Thank you for purchasing the NICE3000^{new} integrated elevator controller.

The NICE3000^{new} is a new-generation integrated elevator controller independently developed and manufactured by Suzhou MONARCH Control Technology Co., Ltd., by optimizing the NICE3000 controller based on a large number of applications and combining new industrial features.

The NICE3000^{new} has the following advantages:

1. It supports high-performance vector control and open-loop low speed running. It can drive both AC asynchronous motor and permanent magnetic synchronous motor (PMSM), and implement switchover between the two types of motors easily by modifying only one parameter.
2. It supports direct parallel control and group control of two elevators, and supports the CANbus and Modbus communication protocols for remote monitoring, which reduces the required quantity of traveling cables.
3. It supports a maximum of 40 floors and is widely applied to elevators used in the residence, office buildings, shopping centers, and hospitals.

This manual describes the correct use of the NICE3000^{new}, including product features, safety information and precautions, installation, parameter setting, commissioning, and maintenance & inspection. Read and understand the manual before using the product, and keep it carefully for reference to future maintenance.

The personnel who involve in system installation, commissioning, and maintenance must receive necessary safety and use training, understand this manual thoroughly, and have related experience before performing operations.

Notes
<ul style="list-style-type: none">• The drawings in the manual are sometimes shown without covers or protective guards. Remember to install the covers or protective guards as specified first, and then perform operations in accordance with the instructions.• The drawings in the manual are shown for description only and may not match the product you purchased.• The instructions are subject to change, without notice, due to product upgrade, specification modification as well as efforts to increase the accuracy and convenience of the manual.• Contact our agents or customer service center if you need a new user manual or have problems during the use.

■ Product Checking

Upon unpacking, check:

- Whether the nameplate model and controller ratings are consistent with your order. The box contains the controller, certificate of conformity, user manual and warranty card.
- Whether the controller is damaged during transportation. If you find any omission or damage, contact your supplier or Monarch immediately.

■ First-time Use

For users who use this product for the first time, read the manual carefully. If you have any problem concerning the functions or performance, contact the technical support personnel of Monarch to ensure correct use.

■ CE Mark

The CE mark on the NICE3000^{new} declares that the controller complies with the European low voltage directive (LVD) and EMC directive.



■ Standard Compliance

The NICE3000^{new} series controller complies with the following LVD and EMC directives and standards:

Directive	Directive Code	Standard
EMC Directive	2004/18/EC	EN 61800-3: 2004+A1: 2012 EN 12015: 2004 EN 12016: 2004+A1: 2008
LVD Directive	2006/95/EC	EN 61800-5-1

The NICE3000^{new} series controller complies with the requirements of the EMC standard on the condition of correct installation and use by following the instructions in chapter 9 "EMC".

Introduction

1. Comparison with the NICE3000

The following table lists the comparison between the NICE3000^{new} and the NICE3000.

Item	NICE3000	NICE3000 ^{new}
Maximum number of floors	31 (standard)	40 (standard)
Maximum elevator speed	4 m/s	4 m/s
I/O terminals	24 inputs, 6 outputs	24 inputs, 6 outputs, 3 higher-voltage inputs
CANbus	1 x CANbus	2 x CANbus
Modbus	1 x Modbus	1 x Modbus
Motor driving type	Separate control for synchronous and asynchronous motors	Integrated control for synchronous and asynchronous motors
No-load-cell startup	Supporting SIN/COS encoder only	Supporting: <ul style="list-style-type: none"> • Push-pull encoder • Open-collector incremental encoder • UVW encoder • SIN/COS encoder • Endat encoder
Control mode	<ul style="list-style-type: none"> • Sensorless vector control (SVC) • Closed-loop vector control (CLVC) 	<ul style="list-style-type: none"> • Sensorless vector control (SVC) • Closed-loop vector control (CLVC) • V/F control
Inside-car commissioning	Not support	Support

2. Connection to peripheral devices

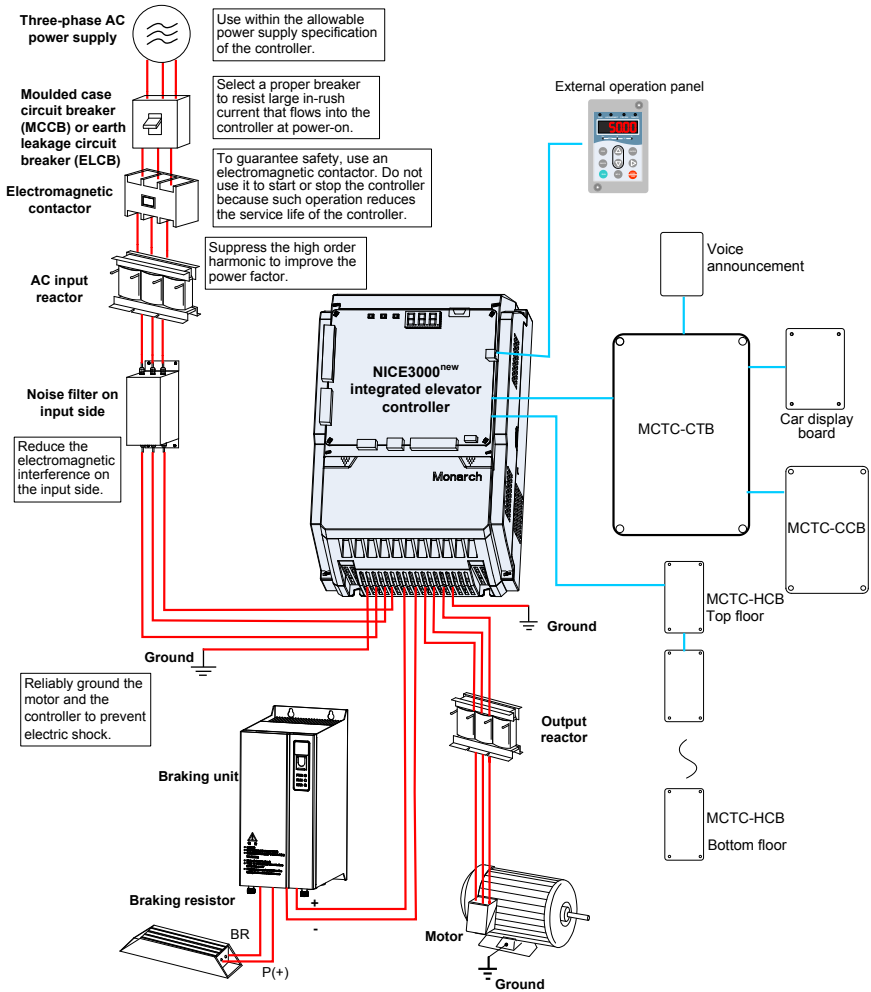

- Do not install the capacitor or surge suppressor on the output side of the controller. Otherwise, it may cause faults to the controller or damage to the capacitor and surge suppressor.
- Inputs/Outputs (main circuit) of the controller contain harmonics, which may interfere with the communication device connected to the controller. Therefore, install an anti-interference filter to minimize the interference.
- For more details on peripheral devices, refer to related selection guidelines.

3. Function list of the NICE3000^{new}

Common Running Functions	
Full collective selective	In automatic running or attendant state, this function enables the elevator to respond both car calls and hall calls. Passengers at any service floor can call the elevator by pressing the up call button and down call button.
Door open time setting	The system automatically determines different door open time for door open for call, command, protection, or delay according to the set door open holding time.
Door open holding	In automatic running state, passengers can press the door open button in the car to delay door open to facilitate goods to be moved in or out.
Door machine service floor setting	You can set the required service floors of the door machines.
Door pre-close by the door close button	During door open holding in automatic running state, passengers can press the door close button to close the door in advance, which improves the efficiency.
Floor number display setting	The system supports display of floor numbers in combinations of numbers and letters, which meets the requirements of special conditions.
Light curtain signal judgment	If the door is blocked by stuff during door close, the light curtain acts and the elevator opens the door. This function is invalid in fire emergency state.
Auxiliary operation box	An optional auxiliary operation box that has the same functions as the main operation box is available.
Independent control of the front door and back door	When there are two doors for a car, automatic control on the two doors depends on your requirements.
Repeat door close	If the door lock is not applied after the elevator performs door close for a certain time, the elevator automatically opens the door and then closes the door again.
Independent command	When the main and auxiliary operation boxes are configured, they can independently control door open/close according to the commands in automatic running state.
Voice announcement	The elevator automatically announces information such as the running direction and next arriving floor during running.
Auto-leveling	The systems implements automatic accurate leveling based on the floor pulse counting and up/down leveling feedback signals.
Response at acceleration	The system allows the elevator to automatically respond to calls from the service floors during acceleration.
Down collective selective control	In automatic running or attendant state, the elevator responds only to hall down calls besides car calls.
Idle elevator returning to base floor	In automatic running state, the elevator automatically returns to the set parking floor and waits for passengers if there is no car call or hall call within the set time.

Landing at another floor	If the door open time exceeds the door open protection time but the door open limit signal is still inactive, the elevator closes the door and then automatically runs to the next landing floor. The system reports fault Err55.
Forced door close	When the door fails to close within the set time due to the action of the light curtain or safety edge, the elevator enters the forced door close state, closes the door slowly, and gives a prompt tone.
Cancellation of wrong calls	Passengers can press the button consecutively twice to cancel wrong calls.
Service floor setting	You can enable or disable the system service for certain floors flexibly based on actual requirements.
Time-based floor service	You can flexibly set the time periods and corresponding service floors or select the service floors by using the service floor switchover switch.
Independent running	The elevator does not respond to any call, and the door needs to be closed manually. In the case of group control, the elevator runs independently out of the group control system.
Attendant running	In attendant state, the running of the elevator is controlled by the attendant.
Low-speed self-rescue	When the elevator is in non-inspection state and stops at non-leveling area, the elevator automatically runs to the leveling area at low speed if the safety requirements are met, and then opens the door.
Door control function	You can set whether the system keeps outputting commands after door open limit and door close limit based on the type of the door machine.
Car arrival gong	After the elevator arrives at the destination floor, the CTB gives a prompt tone.
Hall arrival forecast indicator	When the elevator will arrive at the destination floor soon, the hall arrival forecast indicator becomes ON.
Hall arrival gong	After the elevator will arrive at the destination floor soon, the system outputs the hall arrival gong.
Hall I/O extension function	If the hall I/O terminals are not sufficient, more terminals can be provided by using an HCB-B board.
Car I/O extension function	If the car I/O terminals are not sufficient, more terminals can be provided by using an HCB-B board.
Button stuck check	The system can automatically identify whether a hall call button is stuck and cancel the stuck call, preventing the condition that the elevator cannot close and run due to stuck hall calls.
Automatic startup torque compensation	The system automatically implements startup torque compensation based on the current car load, achieving smooth startup and improving the riding comfort.
Direct travel ride	The system automatically calculates and generates the running curves based on the distance, enabling the elevator to directly stop at the leveling position without creeping.
Automatic generation of optimum curve	The system automatically calculates the optimum speed curve compliant with the human-machine function principle based on the distance, without being limited by the number of curves or short floor.

Service suspension output	When the elevator cannot respond to hall calls, the corresponding terminal outputs the service suspension signal.
Running times recording	In automatic running state, the system automatically records the running times of the elevator.
Running time recording	The system automatically records the accumulative power-on time, working hours, and working days of the elevator.
Automatic door open upon door lock abnormality	If the system detects that the door lock circuit is abnormal during door open/close, the elevator automatically opens and closes the door again, and reports a fault after the set door open/close times is reached.
VIP service	The elevator first directly runs to the VIP floor and provides services for special persons.
Specified elevator preferred	The specified elevator is preferred to respond to calls of specified floors.
Disability service	When the elevator is waiting at the leveling position, if there is a call at this floor from the disability operation box, the door open holding time is prolonged. It is the same for the back door.
Full-load direct running	When the car is full-loaded in automatic running state, the elevator does not respond to hall calls from the passing floors. These halls calls, however, can still be registered, and will be executed at next time of running (in the case of single elevator) or by another elevator (in the case of parallel/group control).
Overload protection	When the car load exceeds the rated elevator load, the elevator alarms and stops running.
Fault data recording	The system automatically records detailed information of faults, which helps improve the efficiency of maintenance and repair.
Inspection-related Functions	
Simple maintenance keypad	The 3-button keypad on the MCB provides the functions such as commissioning the running floors and door open/close.
Operation box commissioning	The operation panel can be connected to the system in the car for elevator commissioning, which improves the commissioning efficiency.
Shaft auto-tuning	Shaft auto-tuning is required before first-time automatic running. During shaft auto-tuning, the elevator runs from the bottom floor to the top floor at the inspection speed and automatically records all position signals in the shaft.
User-defined parameter display	You can view the parameters that are modified and different from the default setting.
Inspection running	After entering the inspection state, the system cancels automatic running and related operations. You can press the up or down call button to make the elevator jog at the inspection speed.
Motor auto-tuning	With simple parameter setting, the system can obtain the motor parameters no matter whether the motor is with-load or without load.
Floor position intelligent correction	Every time the elevator runs to the terminal floor, the system automatically checks and corrects the car position information based on slow-down switch 1, and eliminates over travel top terminal or bottom terminal with use of the slow-down switches.

Dual-speed for inspection	Considering inaccurate running control at high inspection speed but a long running time at low inspection speed, the system provides the dual-speed curve for inspection, which greatly improves the efficiency at inspection.
Test running	The test running includes the fatigue test of a new elevator, car call floor test, hall call test, and tests such as hall call response forbidden, door open/close forbidden, terminal floor limit switch shielded, and overload signal shielded.
Fire Emergency and Security Functions	
Returning to base floor at fire emergency	After receiving a fire emergency signal, the elevator does not respond to any call but directly runs to the fire emergency floor and waits.
Firefighter running	After the elevator enters the firefighter running mode, door open/close is implemented by the jog operation (optional) by using the door open and close buttons rather than automatically. In addition, the elevator responds to only car calls and only one call can be registered once.
Security floor	After the security floor function is enabled, the security floor is used at 10:00 p.m. to 6:00 a.m, and the elevator runs to the security floor first every time, stops and opens the door, and then runs to the destination floor.
Elevator lock	In automatic running state, when the elevator lock switch acts or the set elevator time is reached, the elevator cancels all registered calls, returns to the elevator lock floor, stops running, and turns off the lamp and fan in the car.
Troubleshooting based on fault level	Faults are classified into different levels based on the severity. Different levels of faults are rectified using different methods.
Runaway prevention	The system detects the running state of the elevator in real time. If the elevator speed exceeds the limit, the system immediately stops running of the elevator.
Automatic identification of power failure	The system automatically identifies power failure and outputs the relay signal for emergency evacuation automatic switchover to implement emergency evacuation at power failure.
Automatic running mode switchover at power failure	For the synchronous motor, when the power supply is interrupted, the system can perform automatic switchover between shorting stator braking mode and controller drive mode, implementing quick and stable self-rescue. Shorting stator braking mode: Upon power failure, UPS is used, the motor stator is shorted, and the brake is automatically released, making the car move slowly under the effect of the weighing difference between the car and the counterweight.
Running direction self-identification at power failure	When the power supply is interrupted, the system can automatically identify the current car load and determine the running direction.
Base floor verification	After detecting a position abnormality, the system runs the elevator to each floor until reaching the terminal floor for verification, guaranteeing system security.

Passenger unloading first upon fault	The system automatically determines the fault level. If the safety running conditions are met, the elevator first runs to the leveling position to unload passengers.
Interference degree judgment	The system judges the degree of communication interference.
Earthquake protection	When the earthquake detection device acts and inputs a signal to the system, the elevator lands at the nearest floor and stops running. After the earthquake signal becomes inactive and the fault is reset manually, the elevator restores to normal running.
Current cancellation in ramp mode	For the PMSM, after the elevator decelerates to stop, the holding current of the motor is cancelled in ramp mode, preventing abnormal noise during current cancellation.
Independent working power supply	The NICE3000 ^{new} system supports not only three-phase 380 VAC but also single-phase 220 VAC to meet different applications of the power supply system (such as 220 V UPS)
Automatic voltage identification	The system detects the bus voltage and automatically adjusts the running speed of the elevator to adapt to the situation of insufficient power from power supply (such as emergency UPS).
Parallel/Group Control and Other Functions	
Parallel control	The system supports parallel control of two elevators and provides multiple scheduling algorithms to meet requirements of different customers.
Dispersed waiting	In parallel/group control, the elevators can wait at different floors.
Parallel/Group control exit	If the parallel/group control exit switch of a certain elevator in a parallel/group control system is valid or the time for exiting the parallel/group control is reached, the elevator exits parallel/group control and runs independently. This does not affect normal running of the parallel/group control system.
Parallel/Group control automatic exit	If an elevator in the parallel/group control system cannot respond to calls in time due to faults, the elevator automatically exits the parallel/group control system and runs independently. This does not affect normal running of the parallel/group control system.
Anti-nuisance function	The system automatically judges the number of passengers in the car and compares it with the number of registered car calls. If there are excessive car calls, the system determines that it is nuisance and cancels all car calls. In this case, passengers need to register correct car calls again.
Prompt of non-door zone stop	The system gives a prompt when the elevator stops at a non-door zone area due to faults.
Full-load indication	When the elevator is full-loaded, a full-load indication is displayed on the HCBs and the elevator directly runs to the desired floors.
Interface for intelligent residential management	The system provides an interface for intelligent residential management to perform remote monitoring on the state of elevators in the residential district.

Energy-saving Functions	
Car energy-saving	If there is no running command within the set time, the system automatically cuts off the power supply to the lamp and fan in the car.
Energy-saving running with standby power supply	When the normal power supply is interrupted and the emergency power supply is used, the system reduces the running speed of the elevator in the prerequisite of guaranteeing the smooth running curve.
Arrival gong disabled at night	Within the set time period, the arrival gong is disabled.
Energy-saving of idle door machine	After the car lamp is turned off, the system does not output the door close command, which reduces power consumption of the door machine.

4. Optional functions

Function	Description	Remark
Micro-leveling	After landing at a floor, the elevator may move upward or downward due to the load change and the car door is not aligned with the ground, which is inconvenient for in and out of passengers and goods. In this case, the system allows the elevator to run to the leveling position in the door open state at the leveling speed.	MCTC-SCB required
Power failure emergency evacuation	For the elevator configured with UPS, the system uses the UPS to implement low-speed self-rescue in the case of power failure.	UPS required
Onsite commissioning	The system can control and monitor running of elevators by using the NEMS software.	NEMS software required
Residential monitoring	The control system can be connected to the terminal in the monitoring room. By using the NEMS software, you can view the floor position, running direction, and fault state of the elevator.	NEMS, accessories, and MCTC-MIB required
Door pre-open	During normal stop, when the elevator speed is smaller than 0.2 m/s and the door zone signal is active, the system shorts the door lock by means of the shorting door lock circuit contactor and outputs the door open signal, implementing door pre-open. This improves the elevator use efficiency.	MCTC-SCB required
IC card	Passengers need to use the IC card to go to floors that require authorization.	IC card required

Contents

Preface	1
Introduction.....	3
Chapter 1 Safety Information and Precautions.....	14
1.1 Safety Precautions	14
1.2 General Precautions.....	17
1.3 Protective Functions	19
Chapter 2 Product Information	22
2.1 System Configuration of the NICE3000 ^{new}	22
2.2 Designation Rules and Model Description.....	23
2.3 Models and Specifications.....	24
2.4 Technical Specifications	25
2.5 Physical Appearance and Mounting Dimensions	27
2.6 Optional Parts.....	30
2.7 Selection of Braking Components	31
Chapter 3 Mechanical and Electrical Installation.....	34
3.1 NICE3000 ^{new} Integrated Elevator Controller	34
3.2 CTB Board (MCTC-CTB).....	40
3.3 Display Board (MCTC-HCB).....	43
3.4 CCB Board (MCTC-CCB).....	53
3.5 Selection and Use of the MCTC-PG Card.....	56
3.6 Selection of Peripheral Electrical Devices	59
3.7 Electrical Wiring Diagram of the NICE3000 ^{new} Control System	61
3.8 Installation of Shaft Position Signals	61
Chapter 4 Use of the Commissioning Tools	68
4.1 Use of the Onboard Keypad.....	68
4.2 Use of the LED Operation Panel	71
Chapter 5 System Commissioning and Application Example.....	78
5.1 System Commissioning.....	78
5.2 System Application	89
Chapter 6 Function Code Table.....	104



6.1 Function Code Description	104
6.2 Function Code Groups	104
6.3 Function Code Table.....	105
Chapter 7 Description of Function Codes.....	136
Group F0: Basic Parameters	136
Group F1: Motor Parameter	138
Group F2: Vector Control Parameters.....	141
Group F3: Running Control Parameters.....	143
Group F4: Floor Parameters.....	147
Group F5: Terminal Function Parameters	148
Group F6: Basic Elevator Parameters.....	158
Group F7: Test Function Parameters	170
Group F8: Enhanced Function Parameters.....	171
Group F9: Time Parameters.....	174
Group FA: Keypad Setting Parameters	176
Group Fb: Door Function Parameter	187
Group FC: Protection Function Parameters	189
Group Fd: Communication Parameters.....	193
Group FE: Elevator Function Parameters	195
Group Fr: Leveling Adjustment Parameters	198
Group FF: Factory Parameters.....	200
Group FP: User Parameters.....	200
Chapter 8 Troubleshooting	202
8.1 Maintenance.....	202
8.2 Description of Fault Levels	203
8.3 Fault Information and Troubleshooting.....	205
Chapter 9 EMC.....	222
9.1 Definition of Terms.....	222
9.2 Introduction to EMC Standard	222
9.3 Selection of Peripheral EMC Devices.....	223
9.4 Shielded Cable	226
9.5 Solutions to Common EMC Interference Problems.....	228



Safety Information and Precautions

Chapter 1 Safety Information and Precautions

In this manual, the notices are graded based on the degree of danger:







-  **DANGER** indicates that failure to comply with the notice will result in severe personal injury or even death.
-  **WARNING** indicates that failure to comply with the notice will result in potential risk of severe personal injury or even death.
-  **CAUTION** indicates that failure to comply with the notice will result in minor or moderate personal injury or equipment damage.



In addition, **NOTE** appearing in other chapters indicates that an unintended result or situation may occur if the notice is not complied with.





The notices in this manual you have to observe are aimed at guaranteeing your personal safety, as well as to prevent damage to the controller or the parts connected to it. Read this chapter carefully so that you have a thorough understanding and perform all operations by following the notices in this chapter. Monarch will assume no liability or responsibility for any injury or loss caused by improper operation.

1.1 Safety Precautions

Use Stage	Safety Grade	Precautions
Warning	 WARNING	<ul style="list-style-type: none"> • This controller has hazardous high voltage and the controlled motor is a dangerous rotating device. Failure to comply with the notices may result in personal injury or damage to the property. • Transportation, installation, operation and maintenance of the controller can be performed only by qualified personnel after they get familiar with the safety information in this manual. This is the prerequisite of safe and stable running of the equipment. • Do not open the front cover or touch the power terminals on the main circuit within 10 minutes after the controller is powered off. The capacitor on the DC circuit still has residual high voltage even after power-off. Failure to comply will result in electric shock.

Use Stage	Safety Grade	Precautions
During installation	 DANGER	<ul style="list-style-type: none"> Do not install the equipment if you find water seepage, component missing or damage upon unpacking. Do not install the equipment if the packing list does not conform to the product you received. Install the equipment on incombustible objects such as metal, and keep it away from combustible materials. Failure to comply may result in a fire.
	 WARNING	<ul style="list-style-type: none"> Do not loosen the fixed screws of the components, especially the screws with red mark. Do not install the controller on vibrating parts. Failure to comply may result in damage to the equipment or unexpected accidents.
	 CAUTION	<ul style="list-style-type: none"> Handle the equipment with care during transportation to prevent damage to the equipment. Do not drop wire end or screw into the controller. Failure to comply will result in damage to the controller. Do not use the equipment with damaged or missing components. Failure to comply will result in personal injury. Do not touch the components with your hands. Failure to comply will result in static electricity damage. Install the controller in places free of vibration and direct sunlight.
At wiring	 DANGER	<ul style="list-style-type: none"> Wiring must be performed only by qualified personnel under instructions described in this manual. Failure to comply may result in unexpected accidents. A circuit breaker must be used to isolate the power supply and the controller. Failure to comply may result in a fire. Ensure that the power supply is cut off before wiring. Failure to comply may result in electric shock. Tie the controller to ground properly according to the standard. Failure to comply may result in electric shock.
	 WARNING	<ul style="list-style-type: none"> Never connect the power cables to the output terminals (U, V, W) of the controller. Pay attention to the marks of the wiring terminals and ensure correct wiring. Failure to comply will result in damage to the controller. Never connect the braking resistor between the DC bus terminals (+) and (-). Failure to comply may result in a fire.
	 CAUTION	<ul style="list-style-type: none"> Ensure that the cabling satisfies the EMC requirements and local codes. Use wire sizes recommended in the manual. Failure to comply may result in accidents. Use the shielded cable for the encoder, and ensure that the shield is reliably grounded at one end. Use a twisted cable with twisted distance of 20–30 mm as the communication cable, and ensure that the shield is reliably grounded.

Use Stage	Safety Grade	Precautions
	 DANGER	<ul style="list-style-type: none"> • All peripheral devices must be connected properly according to the circuit wiring instructions provided in this manual. Failure to comply will result in accidents • Cover the controller properly before power-on to prevent electric shock. • Do not open the controller's cover after power-on. Failure to comply may result in electric shock. • Do not touch the controller and peripheral circuits with wet hand. Failure to comply may result in electric shock. • Do not touch any I/O terminal of the controller. Failure to comply may result in electric shock. • The controller performs safety detection on external strong power circuits automatically at the beginning of power-on. Do not touch the U, V, W terminals of the controller or the motor terminals at the moment. Failure to comply may result in electric shock. • Do not touch the fan or the discharging resistor to check the temperature. Failure to comply will result in personal burnt. • Signal detection must be performed only by qualified personnel during operation. Failure to comply will result in personal injury or damage to the controller.
<p>During running</p>	 WARNING	<ul style="list-style-type: none"> • Do not touch the rotating part of the motor during the motor auto-tuning or running. Failure to comply will result in accidents. • Check that the following requirements are met: • The voltage class of the power supply is consistent with the rated voltage class of the controller. • The input terminals (R, S, T) and output terminals (U, V, W) are properly connected. • No short-circuit exists in the peripheral circuit. • The wiring is secured. <p>Failure to comply will result in damage to the controller.</p>
	 CAUTION	<ul style="list-style-type: none"> • For synchronous motor, ensure that motor auto-tuning is performed successfully. Perform trial running before resuming the steel rope so as to make the motor run properly. • Avoid objects falling into the controller when it is running. Failure to comply will result in damage to the controller. • Do not perform the voltage resistance test on any part of the controller because such test has been done in the factory. Failure to comply may result in accidents. • Do not change the default settings of the controller. Failure to comply will result in damage to the controller. • Do not start/stop the controller by turning on or off the contactor. Failure to comply will result in damage to the controller.

Use Stage	Safety Grade	Precautions
During maintenance	 DANGER	<ul style="list-style-type: none"> Do not repair or maintain the controller at power-on. Failure to comply will result in electric shock. Repair or maintain the controller when its voltage is lower than 36 VAC, about 10 minutes after the controller is powered off. Otherwise, the residual voltage in the capacitor may result in personal injury. Do not allow unqualified personnel to repair or maintain the controller. Failure to comply will result in personal injury or damage to the controller.
	 WARNING	<ul style="list-style-type: none"> Repair or maintenance of the controller can be performed only by the warranty center or qualified personnel authorized by Monarch. Failure to comply will result in personal injury or damage to the controller. Power supply must be cut off before repair or maintenance of the controller.
	 CAUTION	<ul style="list-style-type: none"> Set the parameters again after the controller is replaced. All the pluggable components must be plugged or removed only after power-off. Strictly obey the laws and regulations and repair and maintain the elevator equipment periodically. Only timely troubleshooting can ensure the safety of passengers.
Disposal	 CAUTION	<p>The packaging materials, screws and terminal blocks can be re-used and it is suggested that you keep them well for future use.</p>
	 WARNING	<p>The electrolytic capacitors on the main circuits and PCB may explode when they are burnt. Poisonous gas is generated when the plastic parts are burnt. Treat them as ordinary industrial waste.</p>

1.2 General Precautions

1. Requirement on the residual current device (RCD)

The controller generates high leakage current during running, which flows through the protective earthing conductor. Thus install a type- B RCD at primary side of the power supply. When selecting the RCD, you should consider the transient and steady-state leakage current to ground that may be generated at startup and during running of the controller. You can select a specialized RCD with the function of suppressing high harmonics or a general-purpose RCD with relatively large residual current.

2. High leakage current warning

 **DANGER** The controller generates high leakage current during running, which flows through the protective earthing conductor. Earth connection must be done before connection of power supply. Earthing shall comply with local regulations and related IEC standards.

3. Motor insulation test

Perform the insulation test when the motor is used for the first time, or when it is reused after being stored for a long time, or in a regular check-up, in order to prevent the poor insulation of motor windings from damaging the controller. The motor must be disconnected from the controller during the insulation test. A 500-V mega-Ohm meter is recommended for the test. Ensure that the insulation resistance is not less than 5 MΩ.

4. Thermal protection of motor

If the rated capacity of the motor selected does not match that of the controller, especially when the rated power of the controller is greater than that of the motor, adjust the motor protection parameters on the operation panel of the controller or install a thermal relay for the motor circuit for protection.

5. Motor heat and noise

The output of the controller is pulse width modulation (PWM) wave with certain harmonic wave, and therefore, the motor temperature rise, noise, and vibration are slightly greater than those at running with the mains frequency.

6. Voltage-sensitive device or capacitor on the output side of the controller

The controller outputs PWM waves, and therefore, do not install the capacitor for improving power factor or lightning protection voltage-sensitive resistor on the output side of the controller. Otherwise, the controller may suffer transient overcurrent or even be damaged.

7. Contactor on the input and output sides of the controller

When a contactor is installed between the input side of the controller and the power supply, the controller must not be started or stopped by turning on or off the contactor. When a contactor is installed between the output side of the controller and the motor, do not turn on or off the contactor when the controller has output. Otherwise, modules inside the controller may be damaged.

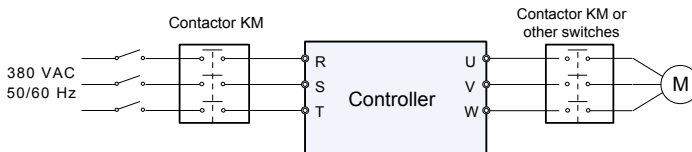

8. Use outside the rated voltage

The controller must not be used outside the allowable voltage range specified in this manual. Otherwise, components inside the controller may be damaged. If required, use a corresponding voltage step-up or step-down device.

9. Surge suppressor

The controller has a built-in voltage dependent resistor (VDR) for suppressing the surge voltage generated when the inductive loads (electromagnetic contactor, electromagnetic relay, solenoid valve, electromagnetic coil and electromagnetic brake) around the controller are switched on or off. If the inductive loads generate very high surge voltage, use a surge suppressor for the inductive load or use a surge suppressor together with a diode.

Note

Do not connect the surge suppressor on the output side of the controller.

10. Altitude and de-rating

In places where the altitude is above 1000 m and the cooling effect reduces due to thin air, it is necessary to de-rate the controller. Contact Monarch for technical support.

11. Disposal

The electrolytic capacitors on the main circuits and PCB may explode when they are burnt. Poisonous gas is generated when the plastic parts are burnt. Treat them as ordinary industrial waste.

12. Adaptable motor

The controller is adaptable to squirrel-cage asynchronous motor or AC PMSM. Select a proper controller according to motor nameplate.

The default parameters configured inside the controller are squirrel-cage asynchronous motor parameters. It is still necessary to perform motor auto-tuning or modify the default values based on actual conditions. Otherwise, the running effect and protection performance will be affected. For PMSM, motor auto-tuning must be performed.

13. Precautions on selecting residual-current circuit breaker (RCCB)

Tripping may be caused if an improper RCCB is selected when the controller drives the motor. This is because the output wave of the controller has high harmonics and the motor cable and the cable connecting the controller and the motor produce leakage current, which is much larger than the current when the motor runs at the mains frequency.

Thus, it is necessary to determine the proper RCCB sensitivity based on the general leakage current of the cables and the motor. The leakage current is dependent on the motor capacity, cable length, insulation class and wiring method. Generally, the leakage current on the output side of the controller is three times of the current when the motor runs at the mains frequency.

1.3 Protective Functions

Adopting different protective functions for different levels of faults, the NICE3000^{new} provides the elevator running system with full abnormality protection. For detailed solutions to the faults, see chapter 8.

Faults of the controller are classified as follows:

1. Speed abnormal

The controller monitors the encoder feedback speed and output torque. Once the feedback speed exceeds the limit or the deviation between the torque limit and the speed feedback is too large, the controller performs protection immediately, reports an alarm and prohibits running.

2. Drive control abnormal

The related faults include drive overcurrent, overvoltage/undervoltage, power input/output phase loss, overload, and storage abnormality. If such a fault occurs, the controller performs protection immediately, stops output, applies the brake and prohibits running.

3. Encoder abnormal

The related faults include encoder phase loss, direction reversing, wire-breaking, and pulse interference. If such a fault occurs, the controller performs protection immediately to avoid unexpected accidents. If pulse interference is large, the controller reports an alarm immediately. If pulse interference is small, the controller performs position correction every time it receives a leveling signal and clears the accumulative error.

4. Leveling sensor abnormal

The related faults include sensor failure or sensor stuck. The controller judges whether a fault occurs based on the leveling signal change. If the leveling signal does not change within the set time, the system reports an alarm.

5. Floor data abnormal

The system stores the floor information through the shaft auto-tuning. If the floor data is abnormal, the system prompts the fault information at the first-time running. During actual running, the controller continuously compares position information input by DIs with the stored floor data. If the deviation is large, the system reports an alarm.



Product Information

Chapter 2 Product Information

2.1 System Configuration of the NICE3000^{new}

The NICE3000^{new} series integrated elevator control system combines the functions of both elevator controller and the high-performance vector controller. It mainly includes the integrated elevator controller, car top board (MCTC-CTB), hall call board (MCTC-HCB), car call board (MCTC-CCB), and optional door pre-open module, and remote monitoring system.

The following figure shows the system components.

Figure 2-1 System components of the NICE3000^{new}

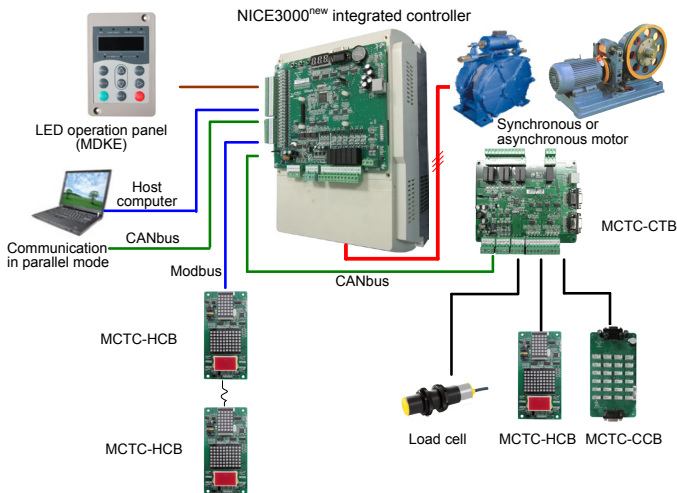

1. It controls the motor based on feedback signals from the encoder, and records information of all position switches in the shaft by pulse, implementing accurate leveling and direct travel ride and guaranteeing running safety.
2. It implements information collection and control of car-related components by means of CANbus communication with the MCTC-CTB.
3. It registers and displays hall calls of all floors with easy address setting by means of Modbus communication with the MCTC-HCB.

The following figure shows the system structure of the NICE3000^{new}.

Figure 2-2 System structure of the NICE3000^{new}

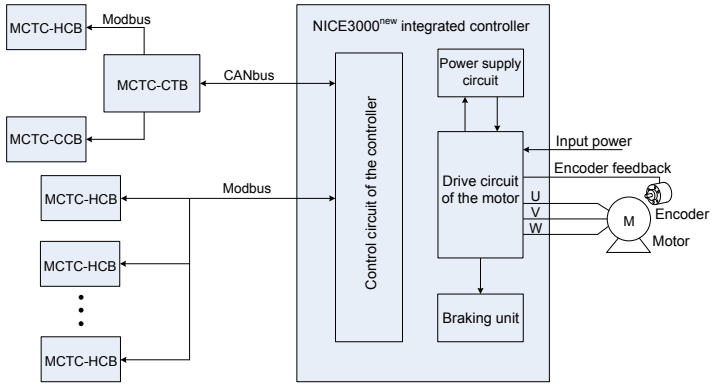

2.2 Designation Rules and Model Description

Figure 2-3 Designation rules and nameplate of the NICE3000^{new}

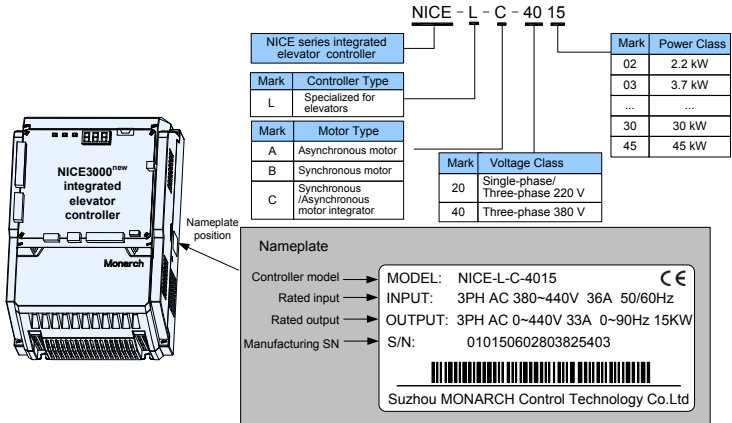

2.3 Models and Specifications

Table 2-1 NICE3000^{new} models and specifications

Controller Model	Power Capacity (kVA)	Input Current (A)	Output Current (A)	Motor Power (kW)
Single-phase 220 V, range: -15% to 20%				
NICE-L-C-2002	2.0	9.2	5.2	1.1
NICE-L-C-2003	2.9	13.3	7.5	1.5
220-NICE-L-C-4007	3.9	17.9	10.3	2.2
220-NICE-L-C-4011	5.9	25.3	15.5	3.7
220-NICE-L-C-4015	7.3	31.3	19	4.0
220-NICE-L-C-4018	8.6	34.6	22.5	5.5
220-NICE-L-C-4022	10.6	42.6	27.7	11
220-NICE-L-C-4030	13.1	52.6	34.6	15
Three-phase 220 V, range: -15% to 20%				
NICE-L-C-2002	4.0	11.0	9.6	2.2
NICE-L-C-2003	5.9	17.0	14.0	3.7
220-NICE-L-C-4007	7.0	20.5	18.0	4.0
220-NICE-L-C-4011	10.0	29.0	27.0	5.5
220-NICE-L-C-4015	12.6	36.0	33.0	7.5
220-NICE-L-C-4018	15.0	41.0	39.0	11.0
220-NICE-L-C-4022	18.3	49.0	48.0	15.0
220-NICE-L-C-4030	23.0	62.0	60.0	18.5
Three-phase 380 V, range: -15% to 20%				
NICE-L-C-4002	4.0	6.5	5.1	2.2
NICE-L-C-4003	5.9	10.5	9.0	3.7
NICE-L-C-4005	8.9	14.8	13.0	5.5
NICE-L-C-4007	11.0	20.5	18.0	7.5
NICE-L-C-4011	17.0	29.0	27.0	11.0
NICE-L-C-4015	21.0	36.0	33.0	15.0
NICE-L-C-4018	24.0	41.0	39.0	18.5
NICE-L-C-4022	30.0	49.5	48.0	22.0
NICE-L-C-4030	40.0	62.0	60.0	30.0
NICE-L-C-4037	57.0	77.0	75.0	37.0
NICE-L-C-4045	69.0	93.0	91.0	45.0

Controller Model	Power Capacity (kVA)	Input Current (A)	Output Current (A)	Motor Power (kW)
NICE-L-C-4055	85.0	113.0	112.0	55.0
NICE-L-C-4075	114.0	157.5	150.0	75.0
NICE-L-C-4090	134.0	180.0	176.0	90.0
NICE-L-C-4110	160.0	214.0	210.0	110.0
NICE-L-C-4132	192.0	256.0	253.0	132.0
NICE-L-C-4160	231.0	307.0	304.0	160.0

Note

1. In terms of single-phase and three-phase 220 VAC, NICE-L-C-2002 and NICE-L-C-2003 are specially designed for 220 VAC. The other models that are marked by prefixing "220-" are modified from the three-phase 380 VAC models.
2. Same models are available for single-phase 220 VAC and three-phase 220 VAC. Pay attentions to the power class of the adaptable motor during the use.
3. Select the proper controller output current based on the rated motor current. Ensure that the controller output current is equal to or greater than the rated motor current.
4. If you require higher voltage or power class, contact Monarch.

2.4 Technical Specifications

Table 2-2 Technical specifications of the NICE3000^{new}

Item		Specification
Basic specifications	Maximum frequency	99 Hz
	Carrier frequency	2–16 kHz, adjusted automatically based on the load features
	Motor control mode	Sensorless vector control (SVC) Closed-loop vector control (CLVC) Voltage/Frequency (V/F) control
	Startup torque	0.5 Hz: 180% (SVC) 0 Hz: 200% (CLVC)
	Speed adjustment range	1:100 (SVC) 1:1000 (CLVC) 1:50 (V/F)
	Speed stability accuracy	±0.5% (SVC) ±0.05% (CLVC)
	Torque control accuracy	±5% (CLVC)
	Overload	60s for 150% of the rated current, 1s for 200% of the rated current
	Motor auto-tuning	With-load auto-tuning; no-load auto-tuning

	Item	Specification
Basic specifications	Distance control	Direct travel ride mode in which the leveling position can be adjusted flexibly
	Acceleration/Deceleration curve	N curves generated automatically
	Slow-down	New reliable slow-down function, automatically identifying the position of the slow-down shelf
	Shaft auto-tuning	32-bit data, recording the position in the shaft accurately
	Leveling adjustment	Flexible and easy leveling adjustment function
	Startup torque compensation	Load cell startup pre-torque compensation No-load-cell startup pre-torque self-adaption
	Real-time clock	Real-time clock for time-based floor service, peak service and automatic password
	Test function	Easy to implement multiple elevators commissioning functions.
	Fault protection	Solutions to different levels of elevator faults
	Intelligent management	Remote monitoring, user management, and group control adjustment
	Security check of peripheral devices after power-on	Security check of peripheral devices, such as grounding and short circuit, after power-on
	Status monitor	Monitoring the state of feedback signals to ensure that the elevator works properly
I/O feature	Digital input (DI)	24 x DI Input specification: 24 V, 5 mA
		3 heavy-current detection input terminals of safety circuit and door lock circuit Input specification: 95–125 V
	Analog input (AI)	AI (voltage range: –10 V to +10 V)
	Communication port	2 CANbus communication ports 1 Modbus communication port
	Output terminal block	6 relay outputs The terminals can be allocated with different functions.
Encoder interface	Supporting different encoders by using an optional PG card	
Operation and display	Keypad	3-digit LED display, implementing certain commissioning functions
	LED operation panel	5-digit LED display, querying/modifying most parameters and monitoring the system state
	Status monitor	Connecting the control system and the host computer, convenient for querying/motoring the system state.

Item		Specification
Environment	Altitude	Below 1000 m (de-rated 1% for each 100 m higher)
	Ambient temperature	-10°C to 40°C (de-rated if the ambient temperature is above 40°C, maximum temperature: 50°C)
	Humidity	Maximum relative humidity 95%, non-condensing
	Vibration	Maximum vibration: 5.9 m/s ² (10–55 Hz, 0.35 mm)
	Storage temperature	-20°C to 60°C
	IP level	IP20
Environment	Pollution degree	PD2
	Power distribution system	TN, TT

2.5 Physical Appearance and Mounting Dimensions

The following figures show the physical appearance and mounting dimensions of the NICE3000^{new}.

Figure 2-4 Physical appearance of the NICE3000^{new}

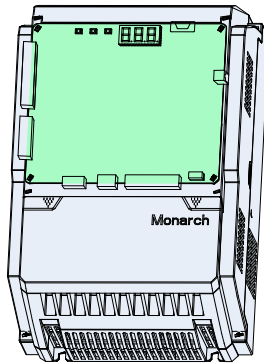
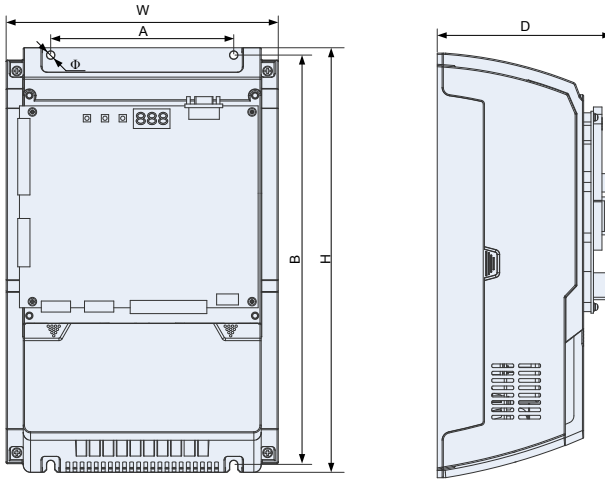

Figure 2-5 Mounting dimensions of the NICE3000^{new}



The NICE3000^{new} has different sizes. The following table lists the mounting dimensions of models under these sizes.

Table 2-3 Mounting dimensions of the NICE3000^{new}

Controller Model	A (mm)	B (mm)	H (mm)	W (mm)	D (mm)	Hole Diameter (mm)	Gross Weight (kg)	Size
Single-phase/Three-phase 220 V, range: -15% to 20%								
NICE-L-C-2002	150	334.5	347	223	143	6.5	5.5	SIZE-C
NICE-L-C-2003								
220-NICE-L-C-4007	150	334.5	347	223	173.5	6.5	7	SIZE-D
220-NICE-L-C-4011								
220-NICE-L-C-4015								
220-NICE-L1-C-4007	190	305	322	208	212	6	7	
220-NICE-L1-C-4011								
220-NICE-L1-C-4015								
220-NICE-L-C-4018	235	541.5	554.5	289.6	223	6.5	14.5	SIZE-E
220-NICE-L-C-4022								
220-NICE-L-C-4030								
Three-phase 380 V, range: -15% to 20%								
NICE-L-C-4002	150	334.5	347	223	143	6.5	5.5	SIZE-C
NICE-L-C-4003								
NICE-L-C-4005								

Controller Model	A (mm)	B (mm)	H (mm)	W (mm)	D (mm)	Hole Diameter (mm)	Gross Weight (kg)	Size
NICE-L -C-4007	150	334.5	347	223	173.5	6.5	7	SIZE-D
NICE-L -C-4011								
NICE-L -C-4015								
NICE-L1-C-4007	190	305	322	208	212	6	7	
NICE-L1-C-4011								
NICE-L1-C-4015								
NICE-L-C-4018	235	541.5	554.5	289.6	223	6.5	14.5	SIZE-E
NICE-L-C-4022								
NICE-L-C-4030								
NICE-L-C-4037	260	580	549	385	265	10	32	SIZE-F
NICE-L-C-4045								
NICE-L-C-4055								
NICE-L-C-4075	343	678	660	473	307	10	47	SIZE-G
NICE-L-C-4090								
NICE-L-C-4110	449	903	880	579	380	10	90	SIZE-H
NICE-L-C-4132								
NICE-L-C-4160								

Note

For the models of other higher power classes that are still not often applied onsite, the preceding table does not list the mounting dimensions. If you need such models, directly contact Monarch.

2.6 Optional Parts

If any optional part in the following table is required, specify it in your order.

Table 2-4 Optional parts of the NICE3000^{new}

Name	Model	Function	Remark
External braking unit	MDBUN	It is provided for the NICE3000 ^{new} of 37 kW and above.	For details, see section 2.7 "Selection of Braking Resistor".
PG card	MCTC-PG-A2	It is used to adapt to the push-pull and open-collector incremental encoders.	-
	MCTC-PG-D	It is used to adapt to the UVW differential encoder and applied to synchronous motor. It requires 5 V power supply.	-
	MCTC-PG-E	It is used to adapt to the SIN/COS encoder.	-
	MCTC-PG-F1	It is used to adapt to the absolute encoder (Heidenhain ECN413/1313)	-
Car top board (CTB)	MCTC-CTB	The MCTC-CTB is the car control board of the NICE3000 ^{new} . It has 8 DI's, 1 AI and 9 relay outputs (7 as standard configuration). It can communicate with the CCB and HCB simultaneously.	-
Hall call board (HCB)	MCTC-HCB	The HCB receives the passenger calls and displays the floor where the elevator is located and the running direction. It can also be used as car display board.	A number of HCB models are available. For details, see section 3.3.
Car call board (CCB)	MCTC-CCB	The MCTC-CCB is another interface for passengers to interact with the control system. It mainly collects the car calls and outputs the call indicator state.	-
External LED operation panel	MDKE	It is the external LED display and operation panel.	It provides the RJ45 interface for connecting to the controller.
Extension cable	MDCAB	It is a standard 8-core network cable and can be connected to MDKE and MDKE3.	The cable length is 3 m in the standard configuration.

2.7 Selection of Braking Components

The NICE3000^{new} models of 30 kW and below have a built-in braking unit, and you only need to connect an external braking resistor between PB and + terminals. For models above 30 kW, you need to install a braking unit and a braking resistor externally.

Select the braking resistor based on the configuration listed in the following table.

Table 2-5 Braking resistor selection for the NICE3000^{new} models

Controller Model	Power of Adaptable Motor (kW)	Max. Resistor (Ω)	Min. Resistance (Ω)	Power of Braking Resistor (W)	Braking Unit
Single-phase 220 V, range: -15% to 20%					
NICE-L-C-2002	1.1	145.0	125.0	300	Built-in
NICE-L-C-2003	1.5	105.0	90.0	450	
220-NICE-L-C-4007	2.2	72.0	63.0	600	
220-NICE-L-C-4011	3.7	43.0	37.0	1100	
220-NICE-L-C-4015	4.0	40.0	35.0	1200	
220-NICE-L-C-4018	5.5	29.0	25.0	1600	
220-NICE-L-C-4022	11.0	18.0	16.0	3500	
220-NICE-L-C-4030	15.0	13.0	13.0	4500	
Three-phase 220 V, range: -15% to 20%					
NICE-L-C-2002	2.2	72.0	65.0	600	Built-in
NICE-L-C-2003	3.7	54.0	50.0	1100	
220-NICE-L-C-4007	4.0	40.0	35.0	1200	
220-NICE-L-C-4011	5.5	29.0	25.0	1600	
220-NICE-L-C-4015	7.5	26.0	22.0	2500	
220-NICE-L-C-4018	11.0	14.5	13.0	3500	
220-NICE-L-C-4022	15.0	13.0	12.5	4500	
220-NICE-L-C-4030	18.5	12.5	12.0	5500	
Three-phase 380 V, range: -15% to 20%					
NICE-L-C-4002	2.2	290	230	600	Built-in
NICE-L-C-4003	3.7	170	135	1100	
NICE-L-C-4005	5.5	115	90	1600	
NICE-L-C-4007	7.5	85	65	2500	
NICE-L-C-4011	11	55	43	3500	
NICE-L-C-4015	15	43	35	4500	
NICE-L-C-4018	18.5	34.0	25	5500	
NICE-L-C-4022	22	24	22	6500	
NICE-L-C-4030	30	20	16	9000	

Controller Model	Power of Adaptable Motor (kW)	Max. Resistor (Ω)	Min. Resistance (Ω)	Power of Braking Resistor (W)	Braking Unit
NICE-L-C-4037	37	16.0	13	11000	MDBUN-60-T
NICE-L-C-4045	45	14.0	11	13500	MDBUN-60-T
NICE-L-C-4055	55	12.0	10	16500	MDBUN-90-T
NICE-L-C-4075	75	16x2	13 x 2	12000 x 2	MDBUN-60-T x 2
NICE-L-C-4090	90	14 x 2	13 x 2	13500x2	MDBUN-60-T x 2
NICE-L-C-4110	110	12 x 2	9 x 2	18000 x 2	MDBUN-90-T x 2
NICE-L-C-4132	132	13.5 x 3	10.5 x 3	14000 x 3	MDBUN-90-T x 3
NICE-L-C-4160	160	12 x 3	9 x 3	18000 x 3	MDBUN-90-T x 3

Note

1. The preceding configuration takes the synchronous motor as an example. The asynchronous motor has poor energy transfer efficiency, and you can reduce the power of the braking resistor or increase the resistance of the braking resistor.

2. It is recommended that you select the braking resistor closest to the minimum resistance.

3. "x 2" indicates that two sets are required. Take NICE-L-C-4110 as an example: "9 x 2, 18000 x 2, MDBUN-90-T x 2" indicates that two sets of (9 Ω , 15000 W) braking resistor + MDBUN-90-T braking unit are connected in parallel to the controller. "x 3" indicates that three sets are required.



Mechanical and Electrical Installation

Chapter 3 Mechanical and Electrical Installation

3.1 NICE3000^{new} Integrated Elevator Controller

3.1.1 Installation Environment Requirements

Item	Requirements
Ambient temperature	-10°C to 50°C
Heat dissipation	Install the controller on the surface of an incombustible object, and ensure that there is sufficient space around for heat dissipation. Install the controller vertically on the support using screws.
Mounting location	Free from direct sunlight, high humidity and condensation
	Free from corrosive, explosive and combustible gas
	Free from oil dirt, dust and metal powder
Vibration	Less than 0.6 g
Protective enclosure	The controllers of plastic housing are whole-unit built-in products operated through remote control and need to be installed in the final system. The final system must have the required fireproof cover, electrical protective cover and mechanical protective cover, and satisfy the regional laws & regulations and related IEC requirements.

3.1.2 Installation Clearance Requirements

The clearance that needs to be reserved varies with the power class of the NICE3000^{new}, as shown in the following figure.

Figure 3-1 Clearance around the NICE3000^{new} for installation

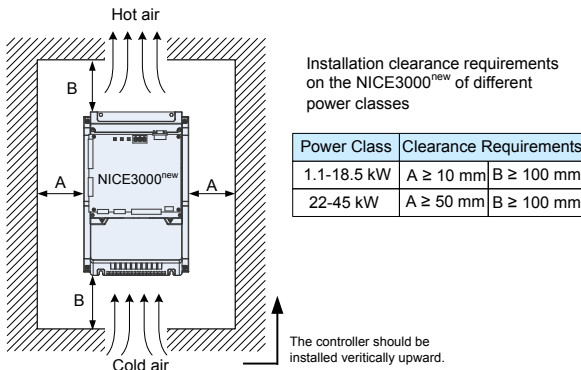

The NICE3000^{new} is installed vertically upward on the support with screws fixed into the four mounting holes, as shown in the following figure.

Figure 3-2 Diagram of mounting holes

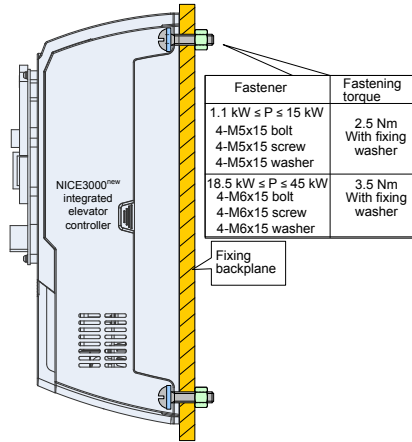

The controller is generally installed in the control cabinet of the elevator equipment room. Pay attention to the following points when designing the control cabinet:

1. The temperature inside the cabinet must not rise to 10°C higher than the temperature outside the cabinet.
2. A closed control cabinet must be configured with a fan (or other air cooling device such as air conditioner) to ensure air circulation.
3. The air from the fan must not blow directly to the drive unit because this easily causes dust adhesion and further a fault on the drive unit.
4. A vent must be available at bottom of the control cabinet to form bottom-up air flow, which prevents heat island effect on the surface of components or partial thermal conductivity effect.
5. If the fan cannot meet the cooling requirements, install an air conditioner in the cabinet or in the equipment room. Note that the temperature inside the cabinet must not be too low; otherwise, condensation may occur, causing short-circuit of components.
6. For special environment where the temperature is high but cannot be reduced effectively, de-rate the controller during use.

3.1.3 Terminal Arrangement and Wiring Description

■ Terminal Arrangement

The following figure shows terminal arrangement of the NICE3000^{new}.

Figure 3-3 Terminal arrangement of the NICE3000^{new}

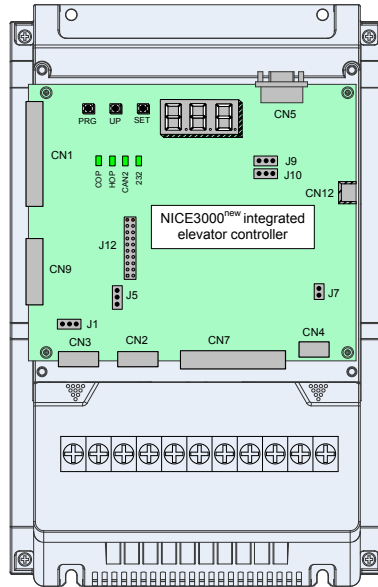

■ Description of Main Circuit Terminals

The following figure shows main circuit terminal arrangement.

Figure 3-4 Main circuit terminal arrangement

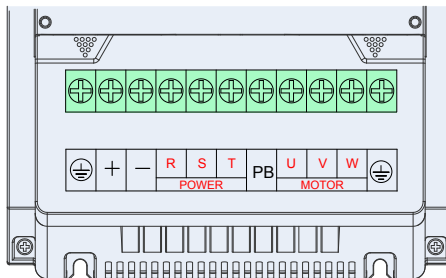

Figure 3-5 Wiring of the main circuit

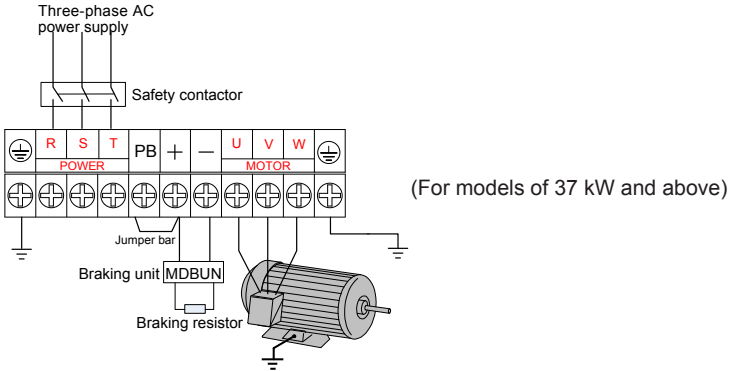
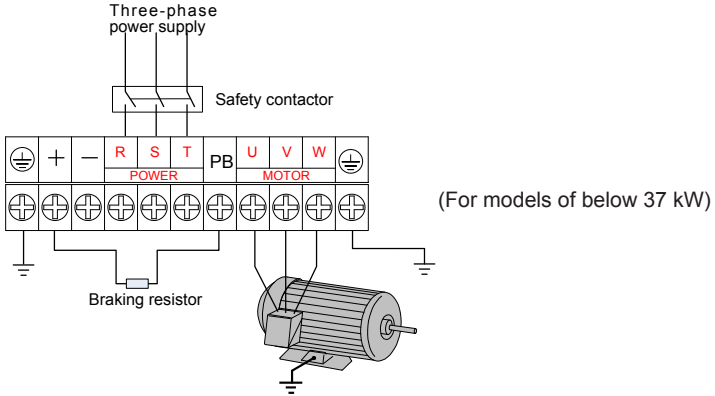



Table 3-1 Description of main circuit terminals

Terminal	Name	Description
R, S, T	Three-phase power input terminals	Provide three-phase power supply.
(+), (-)	Positive and negative terminals of DC bus	Connect the external braking unit and energy feedback unit for models of 37 kW and above.
(+), PB (P)	Terminals for connecting braking resistor	Connect the braking resistor for models of below 37 kW. Connect the DC reactor for models of 37 kW and above. At delivery, the (+) and P terminals are shorted with the jumper bar. If you need not connect the DC reactor, do not remove the jumper bar.
U, V, W	Controller output terminals	Connect the three-phase motor.

Terminal	Name	Description
	Grounding terminal	Must be grounded.



Precautions about wiring of the main circuit terminals are as follows:

1. Select the braking resistor according to the recommended values in the braking resistor selection table.
2. The circuit on the output side must not be short-circuited or grounded.
3. U, V, W cables of the controller must run through the grounding metal pipe and be laid separately or vertically with the control circuit signal cable.
4. If the motor cable is too long, electrical resonance will be generated due to the impact of distributed capacitance, thus damaging the motor insulation or generating higher leakage current, causing the controller to trip in overcurrent protection.
5. The grounding terminal of the main circuit must be tied to the ground reliably with the short and thick PE conductor. The multi-strand copper cable above 4 mm² is recommended, and the grounding resistance must be larger than 4 Ω. Do not connect this terminal to the neutral conductor of the power supply.
6. The requirements for the PE conductor are as follows:
 - The impedance of the PE conductor/cable must be able to bear the probable maximum short-circuit current when a fault occurs.
 - Use a yellow/green cable as the PE conductor.
 - Select the size of the PE conductor according to the following table.

Cross-sectional Area of a Phase Conductor (S)	Min. Cross-sectional Area of Protective Conductor (Sp)
$S \leq 16 \text{ mm}^2$	S
$16 \text{ mm}^2 < S \leq 35 \text{ mm}^2$	16 mm ²
$35 \text{ mm}^2 < S$	S/2

■ Description of Control Circuit Terminals

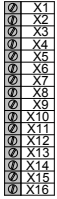
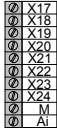
Table 3-2 Description of control circuit terminals

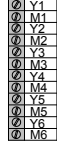
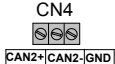
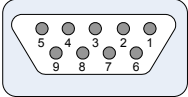
Mark	Code	Terminal Name	Function Description	Terminal Arrangement
CN1	X1 to X16	DI	<ul style="list-style-type: none"> Input voltage range: 10–30 VDC Input impedance: 4.7 kΩ Optocoupler isolation 	 <p>CN1</p>
	X17 to X24	DI	<ul style="list-style-type: none"> Input current limit: 5 mA Functions set in F5-01 to F5-24	
CN9	Ai/M	AI	Used for the analog load cell device	 <p>CN9</p>
	24V/COM	External 24 VDC power supply	24 VDC power supply for the entire board	
CN3	MOD+/-	RS485 differential signal	Standard isolated RS485 communication interface, used for hall call and display	 <p>CN3</p>
	CAN+/-	CANbus differential signal	CANbus communication interface, communication with the CTB	
CN2	X25 to X27/ XCM	Higher-voltage detection terminal	Input voltage range: 110 VAC±15% Safety circuit and door lock circuit, function set in F5-37 to F5-39	 <p>CN2</p>
CN7	Y1/M1 to Y6/M6	Relay output	Normally-open (NO), maximum current and voltage rating: 5 A, 250 VAC Function set in F5-26 to F5-31	 <p>CN7</p>
CN4	CAN2+/-	CAN2 differential signal	CAN2 communication interface, used for parallel/group control	 <p>CN4</p>
CN5	DB9 interface	RS232 communication interface	Used as the interface for commission software, cell monitoring, RS232/RS485 parallel/group control, and software download for the MCB and drive board	 <p>CN5</p>





Mark	Code	Terminal Name	Function Description	Terminal Arrangement
CN12	RJ45 interface	Operation panel interface	Used to connect the external operation panel	 CN12
J1			Optional grounding terminal for AI. The pins marked with "COM" are connected to the ground.	 J1
J5			Used to connect the terminal resistor for the CANbus communication control board; the pins marked with "ON" are connected to the terminal resistor.	 J5
J7			Grounding terminal of the control board. If it is shorted, the ground of the control board is connected to the ground of the controller.	 J7
J12			Interface for connecting the PG card	 J12
J9/ J10			Factory reserved. Do not short them randomly. Otherwise, the controller may not work properly.	-

Table 3-3 Description of indicators on the MCB

Mark	Terminal Name	Function Description
COP	CAN1 communication indicator	When communication between the MCB and the CTB is normal, this indicator is on (green).
HOP	Modbus communication indicator	When communication between the MCB and the HCB is normal, this indicator is on (green).
CAN2	Group control communication indicator	This indicator is steady on (green) when communication for parallel/group control is normal, and blinks when the running in parallel/group mode is normal.
232	Serial communication indicator	This indicator is on (green) when communication with the host computer or cell/remote monitoring board is normal.
X1 to X24	Input signal indicator	This indicator is on when the external input is active.
Y1 to Y6	Output signal indicator	This indicator is on when the system output is active.

3.2 CTB Board (MCTC-CTB)

3.2.1 Dimensions and Installation

The car top board (MCTC-CTB) is the elevator car control board of the NICE3000^{new}. It consists of 8 DI terminals, 1 AI terminal, and 9 relay output terminals (standard: 7). The following figures show the appearance and structure and installation method of the CTB.

Figure 3-6 Appearance and structure of the CTB

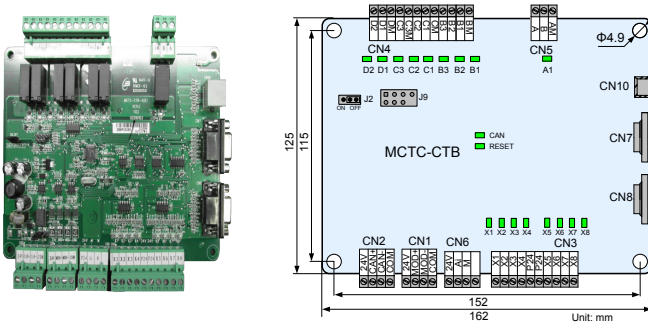
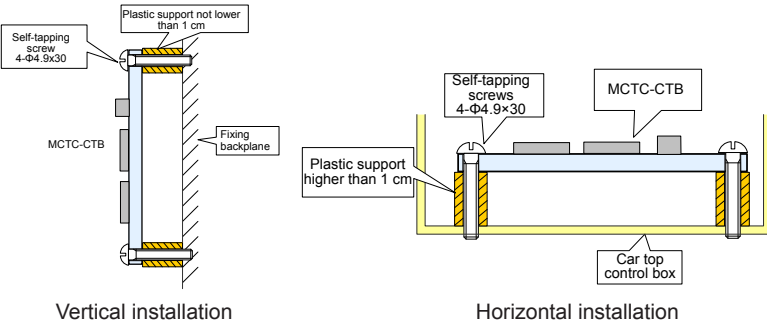



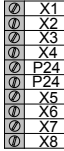
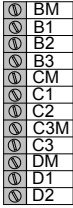

Figure 3-7 Installation method of the CTB (unit: mm)





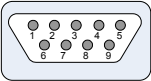

3.2.2 Wiring of CTB Terminals

Table 3-4 Wiring description of CTB terminals

Mark		Terminal Name	Function Description	Terminal Arrangement
CN2	+24V/COM	External 24 VDC power supply	24 VDC power supply for the entire CTB	
	CAN+/CAN-	CANbus communication interface	Connecting the MCB for CANbus communication	
CN1	+24V/COM	24 VDC power supply	24 VDC power supply for the HCB	
	MOD+/MOD-	Modbus communication	Connecting the HCB for Modbus communication	

Mark		Terminal Name	Function Description	Terminal Arrangement
CN6	Ai-M	Load cell signal input	0–10 VDC	 CN6
CN3	P24	24 VDC power supply	DI common terminal	 CN3
	X1	Light curtain 1	DI terminal 1. Photocoupler isolation, unipolarity input 2. Input impedance: 3.3 kΩ Signals of the CTB are active when there is 24 VDC power supply.	
	X2	Light curtain 2		
	X3	Door open limit 1		
	X4	Door open limit 2		
	X5	Door close limit 1		
	X6	Door close limit 2		
	X7	Full-load signal (100%)		
X8	Overload signal (110%)			
CN4	B1-BM	Door open signal 1	Relay output terminal Contact drive capacity: 30 VDC, 1 A	 CN4
	B2-BM	Door close signal 1		
	B3-BM	Forced door close 1		
	C1-CM	Door open signal 2		
	C2-CM	Door close signal 2		
	C3-C3M	Forced door close 2		
	D1-DM	Up arrival signal		
	D2-DM	Down arrival signal		
CN5	A-AM (NC contact) B-AM (NO contact)	Car fan and lamp control	Relay output terminal Contact drive capacity: 250 VAC, 3 A or 30 VDC, 1 A	 CN5
CN7/CN8		DB9-pin port for communication with the CCB	Connecting the CCB CN7 mainly used for front door and ordinary calls CN8 mainly used for back door and disability calls	 CN7/CN8

Mark	Terminal Name	Function Description	Terminal Arrangement
CN10	RJ45 interface	Connecting the external operation panel	 CN10
J2	CTB address jumper in parallel control	Setting the CTB addresses: Short OFF or do not connect the terminal for a single elevator. For the setting in parallel control, see section 5.2.2.	 J2
CAN	CANbus communication indicator	This indicator blinks when communication between the CTB and the MCB is normal, and is steady on when a communication fault occurs.	 CAN RESET
RESET	CANbus communication fault indicator	This indicator blinks and the CANbus communication indicator is steady on when a fault occurs during communication between the CTB and the MCB.	
X1 to X8	DI indicator	This indicator is on (green) when the external input is active.	 X1 X2 X3 X4 X5 X6 X7 X8
A1, B1 to B3, C1 to C3, D1 to D2	Relay output indicator	This indicator is on (green) when the system output is active.	 D2 D1 C3 C2 C1 B3 B2 B1 A1
J9	Reserved	It is factory reserved. Do not short it randomly. Otherwise, the controller may not be used properly.	-

Note

- To prevent external interference on the communication, you are advised to use the shielded twisted pair as communication cables and lay them parallel.
- Connect cables to the terminals according to the terminal marks, and fix the cables.

3.3 Display Board (MCTC-HCB)

As an important interface between users and the control system, the MCTC-HCB receives hall calls and displays the current floor and running direction for the hall. This board can also be used as car display board.

Monarch provides many types of display boards. The following part describes only a few common types. If the types available cannot meet your requirements, you can use a parallel-serial conversion board to make the board provided match your own. For any further requirement, contact Monarch.

The common types to be described are listed in the following table.

Table 3-5 Common HCB types

Type	Description	Size (mm)
HCB-H	Dot-matrix display board (red)	144 x 70 x 18
HCB-R1	Ultrathin dot-matrix display board (red)	144 x 70 x 10
HCB-D2	Ultrathin segment LCD display board (blue background white display)	144 x 70 x 10
HCB-U1	4.3-inch segment LCD display board (blue background white display)	143.5 x 79.2 x 9.4
HCB-V1	6.4-inch segment LCD display board (blue background white display)	131 x 184.6 x 14.2

3.3.1 HCB-H (Dot-Matrix Display Board)

The following figure shows the appearance and dimensions of HCB-H.

Figure 3-8 Appearance and dimensions of HCB-H

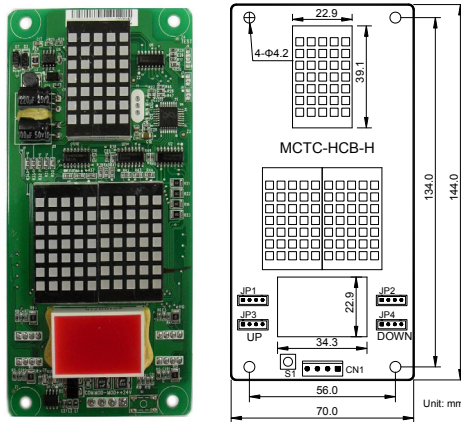

The following figure shows the installation method of HCB-H.

Figure 3-9 Installation method of HCB-H

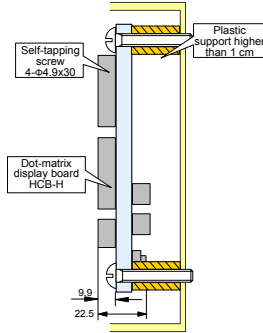

The following table describes the input and output terminals of HCB-H.

Table 3-6 Input and output terminals of HCB-H

Terminal Name	Function	Terminal Wiring
JP1	Interface for the elevator lock switch and up arrival indicator Pins 2 and 3 are for switch input. Pins 1 and 4 are output of the up arrival indicator (24 VDC output, load capacity: 40 mA).	
JP2	Interface for the fire emergency switch and down arrival indicator Pins 2 and 3 are for switch input. Pins 1 and 4 are output of the down arrival indicator (24 VDC output, load capacity: 40 mA).	
JP3	Interface for the up call button and indicator Pins 2 and 3 are for up call input. Pins 1 and 4 are power supply for the up call indicator (24 VDC output, load capacity: 40 mA).	

Terminal Name	Function	Terminal Wiring
JP4	Interface for the down call button and indicator Pins 2 and 3 are for down call input. Pins 1 and 4 are power supply for the down call indicator (24 VDC output, load capacity: 40 mA).	
S1	Button for setting the floor address. Hold down the button to adjust the floor address (range 0–56). After you stop pressing, the address number blinks three times and the setting is successful.	
CN1	Modbus communication and power supply terminal Pins 2 and 3 are for Modbus communication. Pins 1 and 4 are for DC power supply.	

3.3.2 HCB-R1 (Ultrathin Dot-Matrix Display Board)

The following figure shows the appearance and dimensions of HCB-R1.

Figure 3-10 Appearance and dimensions of HCB-R1

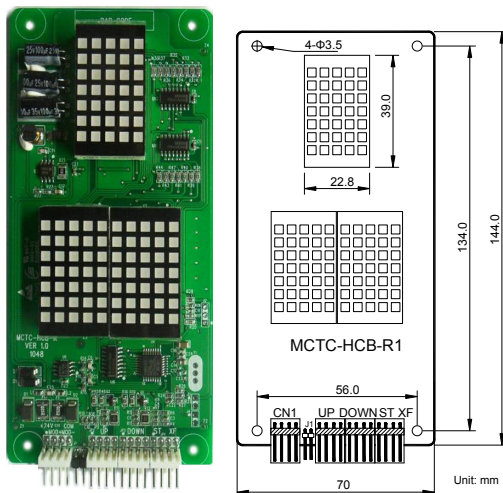

The following figure shows the installation method of HCB-R1.

Figure 3-11 Installation method of HCB-R1

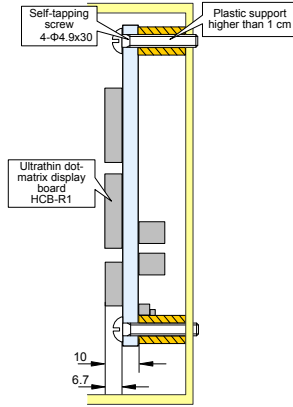

The following table describes the input and output terminals.

Table 3-7 Input and output terminals of HCB-R1

Terminal Name	Function	Terminal Wiring
UP	Interface for the up call button and indicator Pins 2 and 3 are for up call input. Pins 1 and 4 are power supply for the up call indicator (24 VDC output, load capacity: 40 mA).	
DOWN	Interface for the down call button and indicator Pins 2 and 3 are for down call input. Pins 1 and 4 are power supply for the down call indicator (24 VDC output, load capacity: 40 mA).	
XF/ST	Interface for the fire emergency and elevator lock switches Pins 1 and 2 are for fire emergency input. Pins 3 and 4 are for elevator lock input.	
J1	Terminal for setting the floor address. Short J1, and press the UP button or DOWN button to set the floor address (range 0–56). After the jumper cap is removed, the address is automatically stored.	
CN1	Modbus communication and power supply terminal Pins 2 and 3 are for Modbus communication. Pins 1 and 4 are for DC power supply.	

3.3.3 HCB-D2 (Ultrathin Segment LCD Display Board)

The following figure shows the appearance and dimensions of HCB-D2.

Figure 3-12 Appearance and dimensions of HCB-D2

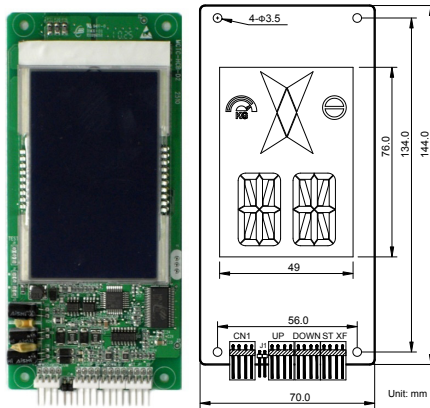

The following figure shows the installation method of HCB-D2.

Figure 3-13 Installation method of HCB-D2

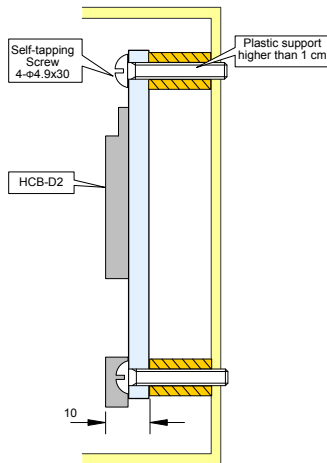

The following table describes the input and output terminals of HCB-D2.

Table 3-8 Input and output terminals of HCB-D2

Terminal Name	Function	Terminal Wiring
UP	Interface for the up call button and indicator Pins 2 and 3 are for up call input. Pins 1 and 4 are power supply for the up call indicator (24 VDC output, load capacity: 40 mA).	
DOWN	Interface for the down call button and indicator Pins 2 and 3 are for down call input. Pins 1 and 4 are power supply for the down call indicator (24 VDC output, load capacity: 40 mA).	
XF/ST	Interface for the fire emergency and elevator lock switch Pins 1 and 2 are for fire emergency input. Pins 3 and 4 are for elevator lock input.	
J1	Terminal for setting the floor address Short J1, and press the UP button or DOWN button to set the floor address (range 0–56). After the jumper cap is removed, the address is automatically stored.	
CN1	Modbus communication and power supply terminal Pins 2 and 3 are for Modbus communication. Pins 1 and 4 are for power supply.	

3.3.4 HCB-U1 (4.3-inch Segment LCD Display Board)

The following figure shows the appearance and dimensions of HCB-U1.

Figure 3-14 Appearance and dimensions of HCB-U1

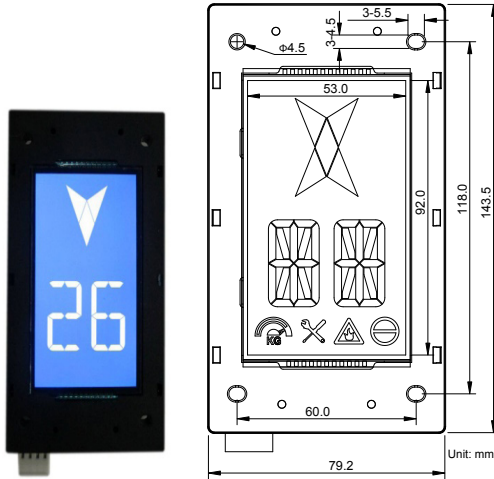

The following figure shows the installation method of HCB-U1.

Figure 3-15 Installation method of HCB-U1

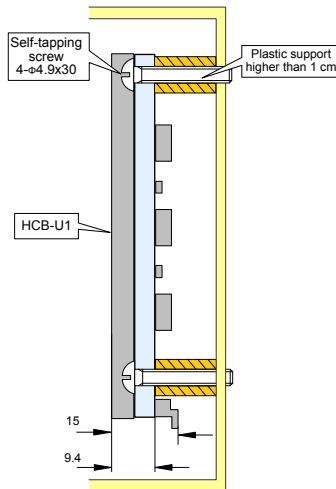

The following table describes the input and output terminals of HCB-U1.

Table 3-9 Input and output terminals of HCB-U1

Terminal Name	Function	Terminal Wiring
J1	Interface for the up call button and indicator Pins 2 and 3 are for up call input. Pins 1 and 4 are power supply for the up call indicator (24 VDC output, load capacity: 40 mA).	
J2	Interface for the down call button and indicator Pins 2 and 3 are for down call input. Pins 1 and 4 are power supply for the down call indicator (24 VDC output, load capacity: 40 mA).	
J3	Interface for the fire emergency and elevator lock switches Pins 1 and 2 are for fire emergency input. Pins 3 and 4 are for elevator lock input.	
S1	Button for setting the floor address. Hold down the button to adjust the floor address (range: 0-56). After you stop pressing, the address number blinks three times, and therefore the setting is successful.	
CN1	Modbus communication and power supply terminal Pins 2 and 3 are for Modbus communication. Pins 1 and 4 are for DC power supply.	

3.3.5 HCB-V1 (6.4-inch Segment LCD Display Board)

The following figure shows the appearance and dimensions of HCB-V1.

Figure 3-16 Appearance and dimensions of HCB-V1

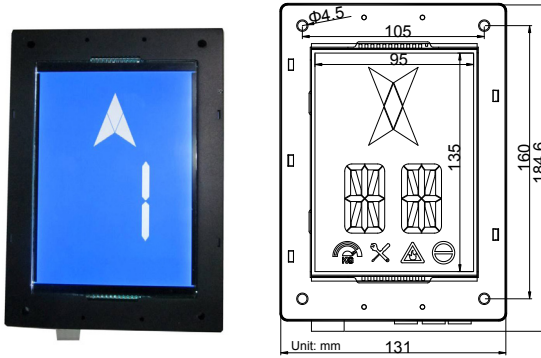

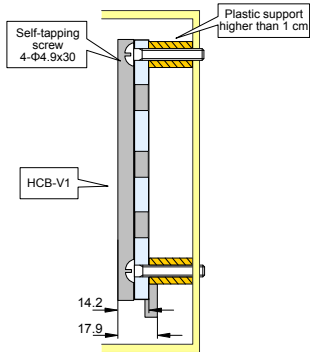

The following figure shows the installation method of HCB-V1.

Figure 3-17 Installation method of HCB-V1

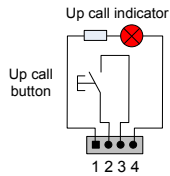
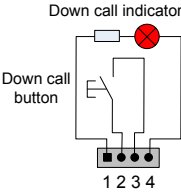
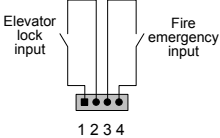

The following table describes the input and output terminals of HCB-V1.

Table 3-10 Input and output terminals of HCB-V1

Terminal Name	Function	Terminal Wiring
J1	Interface for the up call button and indicator Pins 2 and 3 are for up call input. Pins 1 and 4 are power supply for the up call indicator (24 VDC output, load capacity: 40 mA).	
J2	Interface for the down call button and indicator Pins 2 and 3 are for down call input. Pins 1 and 4 are power supply for the down call indicator (24 VDC output, load capacity: 40 mA).	
J3	Interface for the fire emergency and elevator lock switch Pins 1 and 2 are for fire emergency input. Pins 3 and 4 are for elevator lock input.	
S1	Button for setting the floor address. Hold down the button to adjust the floor address (range: 0–56). After you stop pressing, the address number blinks three times, and therefore the setting is successful.	 S1
CN1	Modbus communication and power supply terminal Pins 2 and 3 are for Modbus communication. Pins 1 and 4 are for DC power supply.	 1 2 3 4

3.4 CCB Board (MCTC-CCB)

The car call board (MCTC-CCB) is another interface between users and the control system. Each CCB comprises 24 inputs and 22 outputs, including 16 floor buttons and 8 functional signals. The CCB mainly collects button calls and outputs signals of the button call indicators. The need for 31-floor use can be implemented through cascaded connection. CN2 is an input connector and CN1 is a cascaded output connector.

The following figure shows the appearance and dimensions of the CCB.

Figure 3-18 Appearance and dimensions of the CCB

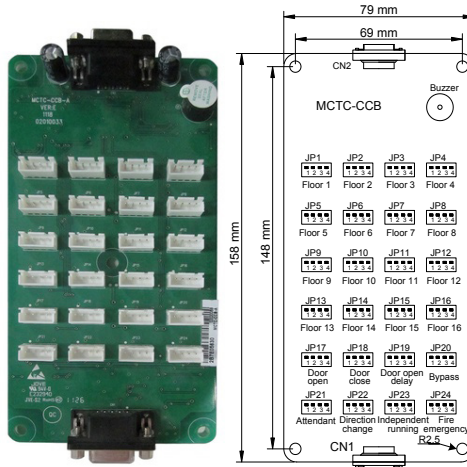

The following figure shows the installation method of the CCB.

Figure 3-19 Installation method of the CCB

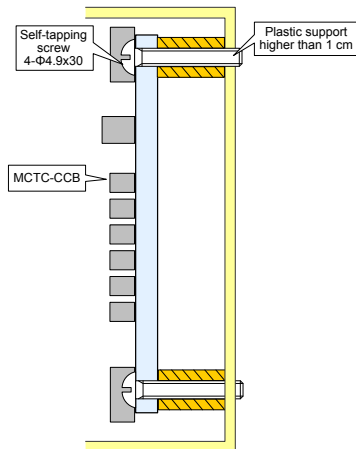

The following table describes the input and output terminals of MCTC-CCB.

Table 3-11 Input and output terminals of MCTC-CCB

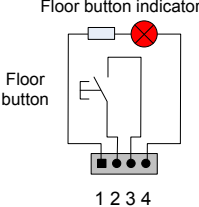
No.	Interface	Pins 2 and 3	Pins 1 and 4	Remarks
1	JP1	Floor 1 button input	Floor 1 display output	 <p style="text-align: center;">1 2 3 4</p> <p>For CCB2 (second MCTC-CCB), the input signal of JPn corresponds to floor (16+n) button input.</p>
2	JP2	Floor 2 button input	Floor 2 display output	
3	JP3	Floor 3 button input	Floor 3 display output	
4	JP4	Floor 4 button input	Floor 4 display output	
5	JP5	Floor 5 button input	Floor 5 display output	
6	JP6	Floor 6 button input	Floor 6 display output	
7	JP7	Floor 7 button input	Floor 7 display output	
8	JP8	Floor 8 button input	Floor 8 display output	
9	JP9	Floor 9 button input	Floor 9 display output	
10	JP10	Floor 10 button input	Floor 10 display output	
11	JP11	Floor 11 button input	Floor 11 display output	
12	JP12	Floor 12 button input	Floor 12 display output	
13	JP13	Floor 13 button input	Floor 13 display output	
14	JP14	Floor 14 button input	Floor 14 display output	
15	JP15	Floor 15 button input	Floor 15 display output	
16	JP16	Floor 16 button input	Floor 16 display output	Invalid for CCB2.
17	JP17	Door open button input	Door open display output	
18	JP18	Door close button input	Door close display output	
19	JP19	Door open delay button input	Door open delay display output	
20	JP20	Direct travel ride input	Non-door zone stop output	
21	JP21	Attendant input	Reserved	
22	JP22	Direction change input	Reserved	
23	JP23	Independent running input	Reserved	
24	JP24	Fire emergency input	Reserved	

Note: Pins 1 and 2 are positive of power supply. The pin with white dot mark or that is rectangular is pin 1.

Note

- Perform wiring strictly according to the terminal marks and ensure that the button is inserted securely.
- The MCTC-CCB has the same interfaces on both ends, and do not make wrong connection when connecting multiple boards in series.

3.5 Selection and Use of the MCTC-PG Card

The NICE3000^{new} can implement CLVC only with use of the MCTC-PG card. The following figures show the appearance of the MCTC-PG card and its installation on the controller. Directly insert the J1 terminal of the MCTC-PG card into the J12 terminal of the controller.

Figure 3-20 Appearance of the MCTC-PG card and its installation on the controller

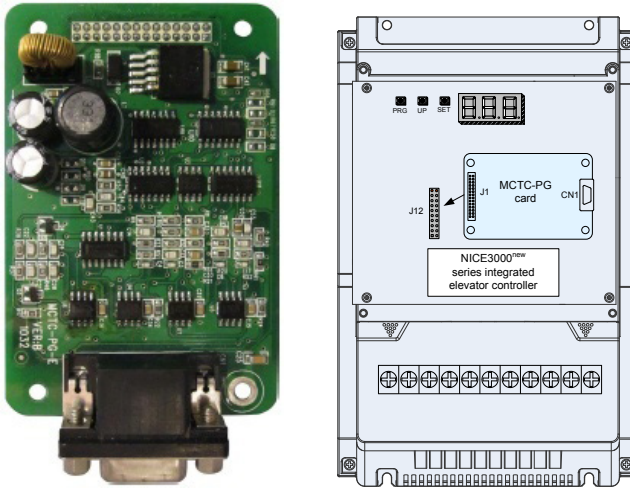

3.5.1 Selection of the MCTC-PG Card

Monarch provides four PG card models, MCTC-PG-A2, MCTC-PG-D, MCTC-PG-E and MCTC-PG-F1 for different encoder types, as described in the following table.

Table 3-12 Selection of the MCTC-PG card models

Encoder Type	Adaptable PG Card	Appearance
<ul style="list-style-type: none"> • Push-pull encoder • Open-collector incremental encoder 	MCTC-PG-A2	
UVW encoder	MCTC-PG-D	

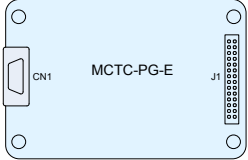
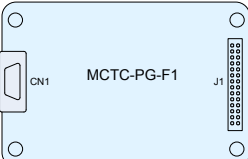
Encoder Type	Adaptable PG Card	Appearance
SIN/COS encoder	MCTC-PG-E	
Absolute encoder (ECN413/1313)	MCTC-PG-F1	

3.5.2 Terminal Wiring and Description of the MCTC-PG Card

The MCTC-PG card is connected to the controller and the encoder as follows:

The J1 terminal and CN1 terminal of the MCTC-PG card are respectively connected to the J12 terminal of the MCB on the controller and the encoder of the motor.

Different MCTC-PG card models are connected to the MCB in the same way. The connection method to the encoder depends on the CN1 terminal of the model.

The following figure shows the wiring between MCTC-PG-E and the controller.

Figure 3-21 Wiring between MCTC-PG-E and the controller

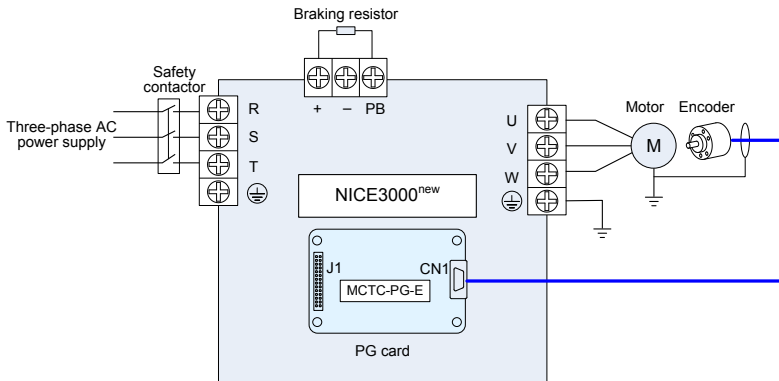

The following table defines the CN1 terminals of different MCTC-PG card models.

Table 3-13 Definitions of the CN1 terminals of different MCTC-PG card models

MCTC-PG-A2		MCTC-PG-D				MCTC-PG-E				MCTC-PG-F1									
1	15V	1	A+	6	NC	11	W+	1	B-	6	A-	11	C-	1	B-	6	A-	11	CLK-
2	PGM	2	A-	7	U+	12	W-	2	NC	7	COM	12	D+	2	NC	7	GND	12	DATA+
3	PGA	3	B+	8	U-	13	VCC	3	Z+	8	B+	13	D-	3	NC	8	B+	13	DATA-

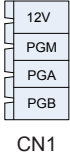
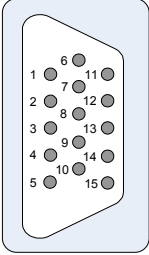
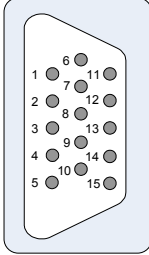
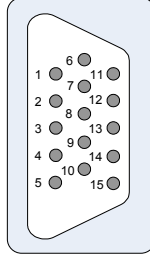
MCTC-PG-A2		MCTC-PG-D					MCTC-PG-E					MCTC-PG-F1							
4	PGB	4	B-	9	V+	14	COM	4	Z-	9	VCC	14	NC	4	NC	9	5V (Up)	14	NC
		5	NC	10	V-	15	NC	5	A+	10	C+	15	NC	5	A+	10	CLK+	15	5V (Sensor)
 <p>CN1</p>		 <p>CN1</p>					 <p>CN1</p>					 <p>CN1</p>							

3.5.3 Precautions on Connecting the MCTC-PG Card

1. The cable from the MCTC-PG card to the encoder must be separated from the cables of the control circuit and the power circuit. Parallel cabling in close distance is forbidden.
2. The cable from the MCTC-PG card to the encoder must be a shielded cable. The shield must be connected to the PE on the controller side. To minimize interference, single-end grounding is suggested.
3. The cable from the MCTC-PG card to the encoder must run through the duct separately and the metal shell is reliably grounded.

3.5.4 Selection of Adaptable Motor

The main counters of the electrical relationship between the controller and the motor are voltage and current.

1. In general elevator applications, the input mains voltage is 380 V, and the motor voltage can only be equal to or smaller than 380 V. Thus, when selecting the NICE3000^{new}, you can take only the current of the motor into consideration.
2. When the NICE3000^{new} is designed, large safety allowance is reserved for the main power module. The controller can run properly within the nominal output current. During stable running, the maximum output torque is 150% of the rated torque and can reach up to 200% of the rated torque for a short time.

Therefore, for the motor with the rated voltage of 380 V, you can select the controller of the same power class. As long as the rated current of the motor is smaller than the output current of the controller, the controller of the same power class can also be used.

Generally speaking, select an adaptable motor based on the output current of the controller, and ensure that the rated current of the motor is equal to or smaller than the output current of the controller. For technical specifications of the controller, see section 2.3.

3.6 Selection of Peripheral Electrical Devices

3.6.1 Description of Peripheral Electrical Devices

1. Do not install the capacitor or surge suppressor on the output side of the controller. Otherwise, it may cause faults to the controller or damage to the capacitor and surge suppressor.
2. Inputs/Outputs (main circuit) of the controller contain harmonics, which may interfere with the communication device connected to the controller. Therefore, install an anti-interference filter to minimize the interference.
3. Select the peripheral devices based on actual applications as well as by referring to section 3.6.2.

The following table describes the peripheral electrical devices.

Table 3-14 Description of peripheral electrical devices

Part	Mounting Location	Function Description
MCCB	Forefront of controller power input side	Cut off the power supply of the controller and provide short-circuit protection.
Safety contactor	Between MCCB and the controller input side	Apply/Cut off the power supply of the controller. The close/open of the contactor is controlled by the external safety circuit.
AC input reactor	Controller input side	Improve the power factor of the input side. Eliminate the higher harmonics on the input side to provide effective protection on the rectifier bridge. Eliminate the input current unbalance due to unbalance between the power phases.
AC output reactor	Between the controller output side and the motor, close to the controller	If the distance between the controller and the motor is greater than 100 m, install an AC output reactor.

3.6.2 Selection of Peripheral Electrical Devices

Proper cable specification and cabling greatly improves anti-interference capability and safety of the system, facilitating installation and commissioning and enhancing system running stability.

The following table describes the specifications of peripheral electrical devices for selection.

Table 3-15 Specification of peripheral electrical devices for selection

Controller Model	MCCB (A)	Contactor (A)	Cable of Main Circuit (mm ²)	Cable of Control Circuit (mm ²)	Grounding Cable (mm ²)
Single-phase 220 V, range: -15% to 20%, 50/60 Hz					
NICE-L-C-2002	16	12	1	0.75	1
NICE-L-C-2003	20	18	2.5	0.75	2.5
220-NICE-L-C-4007	25	18	4	0.75	4

Controller Model	MCCB (A)	Contactor (A)	Cable of Main Circuit (mm ²)	Cable of Control Circuit (mm ²)	Grounding Cable (mm ²)
220-NICE-L-C-4011	40	25	6	0.75	6
220-NICE-L-C-4015	50	32	6	0.75	6
220-NICE-L-C-4018	50	38	6	0.75	6
220-NICE-L-C-4022	63	50	10	0.75	10
220-NICE-L-C-4030	80	65	16	0.75	16
Three-phase 220 V, range: -15% to 20%, 50/60 Hz					
NICE-L-C-2002	16	12	1.5	0.75	1.5
NICE-L-C-2003	25	18	2.5	0.75	2.5
220-NICE-L-C-4007	32	25	4	0.75	4
220-NICE-L-C-4011	40	32	6	0.75	6
220-NICE-L-C-4015	50	38	6	0.75	6
220-NICE-L-C-4018	63	40	10	0.75	10
220-NICE-L-C-4022	80	50	10	0.75	10
220-NICE-L-C-4030	100	65	16	0.75	16
Three-phase 380 V, range: -15% to 20%, 50/60 Hz					
NICE-L-C-4002	10	9	0.75	0.75	0.75
NICE-L-C-4003	16	12	1.5	0.75	1.5
NICE-L-C-4005	25	18	2.5	0.75	2.5
NICE-L-C-4007	32	25	4	0.75	4
NICE-L-C-4011	40	32	6	0.75	6
NICE-L-C-4015	50	38	6	0.75	6
NICE-L-C-4018	63	40	10	0.75	10
NICE-L-C-4022	80	50	10	0.75	10
NICE-L-C-4030	100	65	16	0.75	16
NICE-L-C-4037	100	80	25	0.75	16
NICE-L-C-4045	125	95	35	0.75	16
NICE-L-C-4055	160	115	50	0.75	25
NICE-L-C-4075	225	170	70	0.75	35
NICE-L-C-4090	250	205	95	0.75	50
NICE-L-C-4110	315	245	120	0.75	60
NICE-L-C-4132	350	300	120	0.75	60
NICE-L-C-4160	400	300	150	0.75	75

Note

To prevent the strong power from interfering with the weak power, the strong-power cables must be separated from the weak-power cables during cabling in the shaft. Grounding cables must be used to separate strong-power and weak-power traveling cables. "Strong power" refers to the voltage of 36 V and above.

3.7 Electrical Wiring Diagram of the NICE3000^{new} Control System

Figure 3-22 Electrical wiring diagram of the NICE3000^{new} control system

See the last page of this chapter.

3.8 Installation of Shaft Position Signals

In elevator control, to implement landing accurately and running safely, the car position needs to be identified based on shaft position signals.

These shaft position signals include the leveling switches, up/down slow-down switches, up/down limit switches, and up/down final limit switches.

These shaft position signals are directly transmitted by the shaft cables to the MCB of the controller. For the electrical wiring method, refer to Figure 3-22.

The following figure shows the arrangement of shaft position signals in the shaft.

Figure 3-23 Arrangement of shaft position signals

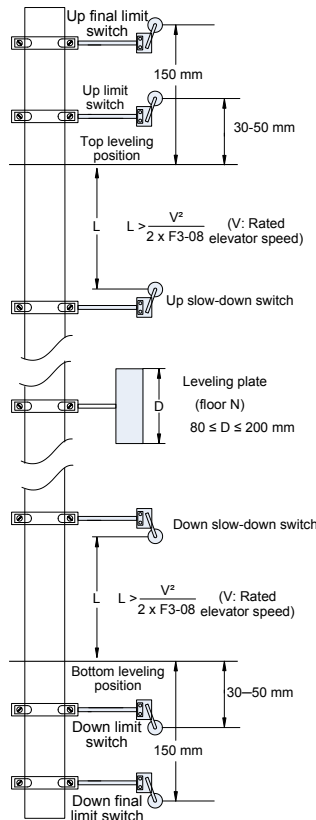

3.8.1 Installation of Leveling Signals

Leveling signals comprise the leveling switch and leveling plate and are directly connected to the input terminal of the controller. It is used to enable the car to land at each floor accurately.

The leveling switches are generally installed on the top of the car. The NICE3000^{new} system supports the installation of 1–3 leveling switches. The leveling plate is installed on the guide rail in the shaft. A leveling plate needs to be installed at each floor. Ensure that leveling plates at all floors are mounted with the same depth and verticality.

The following figure shows the installation of leveling signals

Figure 3-24 Installation of leveling signals

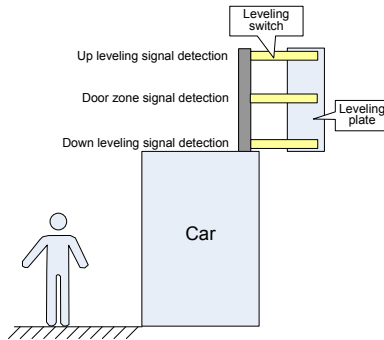

The following table describes the installation requirements of leveling switches

Table 3-16 Installation requirements of leveling switches

Number of Leveling Switches	Installation Method	Connecting to Input Terminals of Controller	Setting of Function Code
1			F5-01 = 0 F5-02 = 35 (NC) F5-03 = 0
			F5-01 = 0 F5-02 = 03 (NO) F5-03 = 0

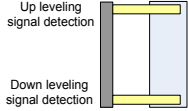
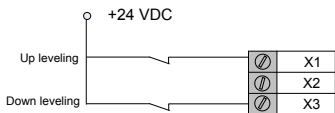
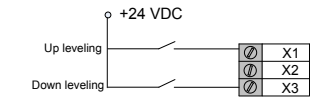
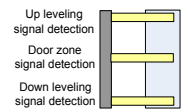
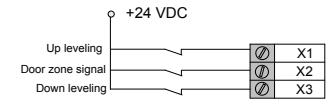
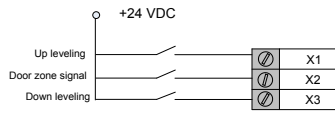
Number of Leveling Switches	Installation Method	Connecting to Input Terminals of Controller	Setting of Function Code
2			F5-01 = 33 (NC) F5-02 = 0 F5-03 = 34 (NC)
			F5-01 = 01 (NO) F5-02 = 0 F5-03 = 02 (NO)
3			F5-01 = 33 (NC) F5-02 = 35 (NC) F5-03 = 34 (NC)
			F5-01 = 01 (NO) F5-02 = 03 (NO) F5-03 = 02 (NO)

Note

- When installing leveling plates, ensure that the plates at all floors are mounted with the same depth and verticality. Otherwise, the leveling accuracy will be affected. The recommended length of the plate is 80–200 mm.
- More leveling input signals need to be added if the door pre-open function is used. In this case, you need to increase the length of the plate properly. For details on the door pre-open module, contact the local agent or Monarch.

3.8.2 Installation of Slow-Down Switches

The slow-down switch is one of the key protective components of the NICE3000^{new}, protecting the elevator from over travel top terminal or over travel bottom terminal at maximum speed when the elevator position becomes abnormal.

The NICE3000^{new} system supports a maximum of three pairs of slow-down switches. The slow-down switch 1, slow-down switch 2 and slow-down switch 3 are installed from the two ends of the shaft to the middle floor one by one. Generally, only one pair of slow-down switches is required for the low-speed elevator. Two or three pairs of slow-down switches are required for the high-speed elevator.

The slow-down distance L indicates the distance from the slow-down switch to the leveling plate at the terminal floor. The calculating formula is as follows:

$$L > \frac{V^2}{2 \times F3-08}$$

In the formula, "L" indicates the slow-down distance, "V" indicates the F0-04 (Rated elevator

speed), and "F3-08" indicates the special deceleration rate.

The default value of F3-08 (Special deceleration rate) is 0.9 m/s^2 . The slow-down distances calculated based on different rated elevator speeds are listed in the following table:

Table 3-17 Slow-down distances based on different rated elevator speeds

Rated Elevator Speed (m/s)	0.25	0.4	0.5	0.63	0.75	1	1.5	1.6	1.75	2	2.5	3	3.5	4
Distance of Slow-down 1 (m)	0.2	0.2	0.2	0.2	0.4	0.7	1.5	1.7	2.0	2.0	2.0	2.0	2.0	2.0
Distance of Slow-down 2 (m)	None									2.5	4.0	4.0	4.0	4.0
Distance of Slow-down 3 (m)	None											6	8	11
<p>"V" indicates the elevator speed, and precautions on the actual installation distance are as follows:</p> <ul style="list-style-type: none"> • $V < 1 \text{ m/s}$: The actual installation distances of the slow-down switches should be close to the values recommended in this table. • $1 \text{ m/s} \leq V \leq 2 \text{ m/s}$: The actual installation distances of the slow-down switches are allowed to have an error within $\pm 0.1 \text{ m}$ based on the values recommended in this table. • $2 \text{ m/s} < V \leq 4 \text{ m/s}$: The actual installation distances of the slow-down switches are allowed to have an error within $\pm 0.3 \text{ m}$ based on the values recommended in this table. 														

Note

- The slow-down distances above are calculated on the basis of the default values (special deceleration rate 0.9 m/s^2 , and acceleration rate and deceleration rate 0.6 m/s^2).
- Increasing the acceleration rate and deceleration rate or reducing the special deceleration rate may bring safety hazard. If any change is in need, re-calculate the slow-down distance by using the above formula.

3.8.3 Installation of Limit Switches

The up limit switch and down limit switch protect the elevator from over travel top/bottom terminal when the elevator does not stop at the leveling position of the terminal floor.

- The up limit switch needs to be installed 30–50 mm away from the top leveling position. The limit switch acts when the car continues to run upward 30–50 mm from the top leveling position.
- The down limit switch needs to be installed 30–50 mm away from the bottom leveling position. The limit switch acts when the car continues to run downward 30–50 mm from the bottom leveling position.

3.8.4 Installation of Final Limit Switches

The final limit switch is to protect the elevator from over travel top/bottom terminal when the elevator does not stop completely upon passing the up/down limit switch.

- The up final limit switch is mounted above the up limit switch. It is usually 150 mm away from the top leveling position.
- The down final limit switch is mounted below the down limit switch. It is usually 150 mm away from the bottom leveling position.

Figure 3-22 Electrical wiring diagram of the NICE3000^{new} control system

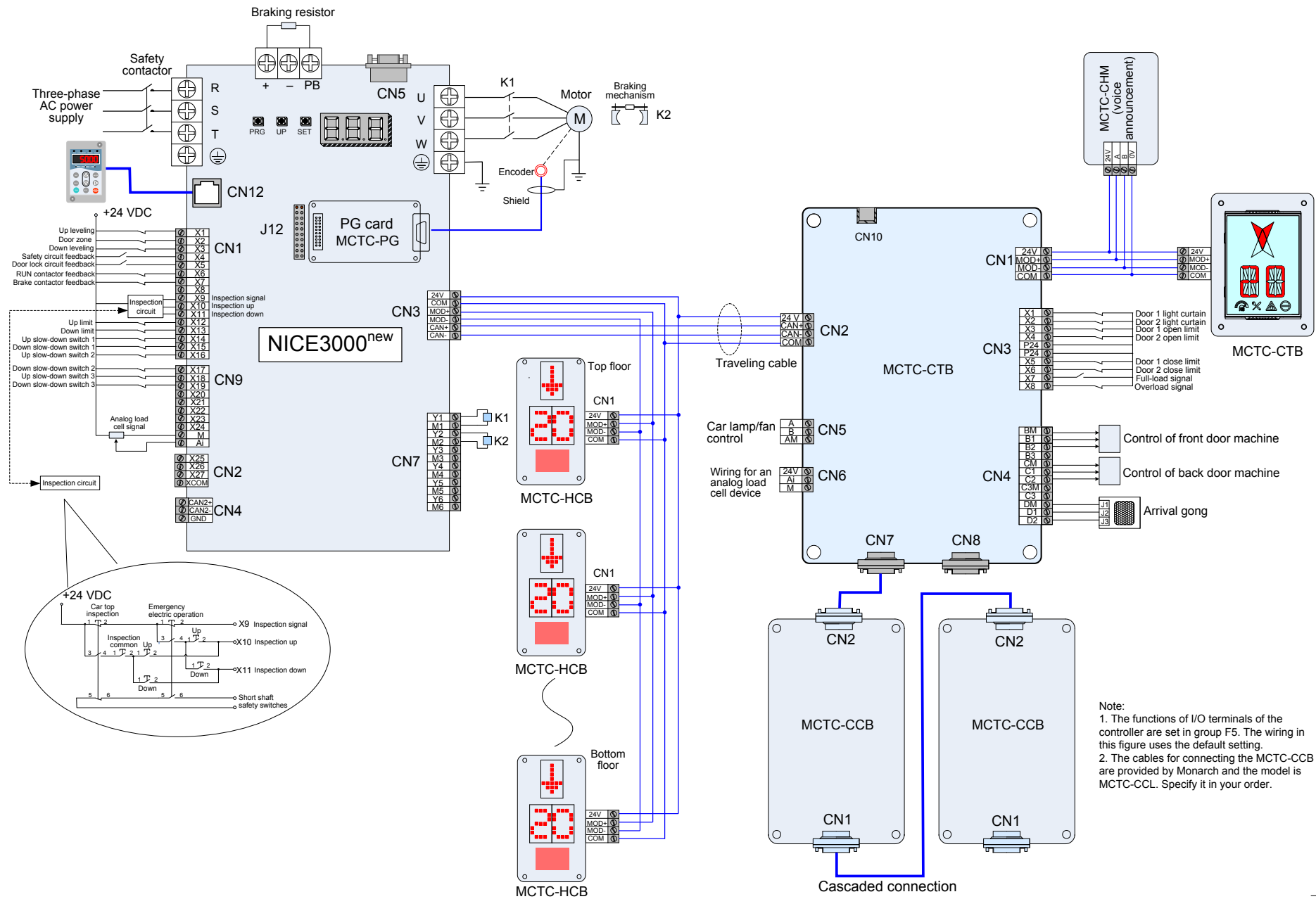

Note:
 1. The functions of I/O terminals of the controller are set in group F5. The wiring in this figure uses the default setting.
 2. The cables for connecting the MCTC-CCB are provided by Monarch and the model is MCTC-CCL. Specify it in your order.



Use of the Commissioning Tools

Chapter 4 Use of the Commissioning Tools

The NICE3000^{new} supports three commissioning tools, 3-button keypad on the MCB, LED operation panel, and host computer monitoring software.

Tool	Function Description	Remark
Onboard 3-button keypad	It is used to enter the shaft commissioning commands and view floor information.	Standard
LED operation panel	It is used to view and modify parameters related to elevator drive and control.	Optional
Host computer monitoring software	It is used to monitor the current elevator state, view and modify all parameters, and upload and download parameters on the PC.	Optional

The following part describes the commonly used keypad and LED operation panel in detail.

4.1 Use of the Onboard Keypad

The onboard keypad consists of three 7-segment LEDs and three buttons. You can view information about the controller and enter simple commands on the keypad.

Note

The keypad is exposed, and pay attentions to the following points during use:

1. Wear insulated gloves when performing operations on the keypad to prevent electric shock or damage to the controller components due to electrostatic discharge.
2. Do not use a metal or sharp tool to press the button to prevent the short-circuit fault or damage to the components on the MCB.

The following figure shows the appearance of the keypad.

Figure 4-1 Appearance of the keypad

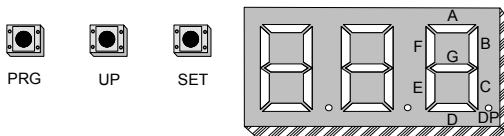

As shown in the preceding figure, the three buttons are PRG, UP, and SET. The functions of the three buttons are as follows:

- PRG: Press this button in any state to display the current function group number.
You can press the UP button to change the function group number.
- UP: Press this button to increase the function group number.

Currently, the MCB defines a total of 13 function code groups, namely, F0 to F9, and FA to FC. You can press the UP button to display them in turn. In addition, in special

function code group menu, you can input simple references by using the UP button.

- SET: In the function code group menu, press this button to enter the menu of the function code group.

In special function code group menu, after you input a simple reference and press this button to save the setting, the display will return to the F0 menu by default.

The following figure shows the setting of increasing the called floor to 5.

Figure 4-2 Setting the called floor

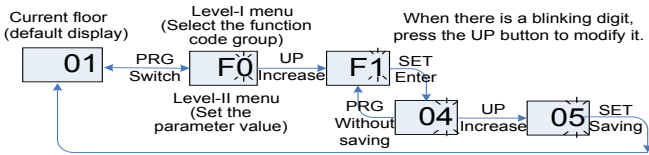

The function code groups displayed on the keypad are described as follows:

1. F0: display of floor and running direction

The F0 menu is displayed on the keypad by default upon power-on. The first 7-segment LED indicates the running direction, while the last two 7-segment LEDs indicate the current floor number of the elevator.

When the elevator stops, the first 7-segment LED has no display. When the elevator runs, the first 7-segment LED blinks to indicate the running direction.

When a system fault occurs, the 7-segment LEDs automatically display the fault code and blink. If the fault is reset automatically, the F0 menu is displayed.

2. F1: command input of the running floor

After you enter the F1 menu, the 7-segment LEDs display the bottom floor (F6-01). You can press the UP button to set the destination floor within the range of lowest to top and then press the SET button to save the setting. The elevator runs to the destination floor, and the display automatically switches over to the F0 menu at the same time.

3. F2: fault reset and fault code display

After you enter the F2 menu, the 7-segment LEDs display "0". You can press the UP button to change the setting to 1 or 2.

- Display "1": If you select this value and press the SET button, the system fault is reset. Then, the display automatically switches over to the F0 menu.
- Display "2": If you select this value and press the SET button, the 7-segment LEDs display the 11 fault codes and occurrence time circularly. You can press the PRG button to exit.

4. F3: time display

After you enter the F3 menu, the 7-segment LEDs display the current system time circularly.

5. F4: contract number display

After you enter the F4 menu, the 7-segment LEDs display the user's contract number.

6. F5: running times display

After you enter the F5 menu, the 7-segment LEDs display the elevator running times circularly.

7. F6: door open/close control

After you enter the F6 menu, the 7-segment LEDs display "1-1", and the UP and SET buttons respectively stand for the door open button and door close button. You can press the PRG button to exit.

8. F7: shaft auto-tuning command input

After you enter the F7 menu, the 7-segment LEDs display "0". You can select 0 or 1 here, where "1" indicates the shaft auto-tuning command available.

After you select "1" and press the SET button, shaft auto-tuning is implemented if the conditions are met. Meanwhile, the display switches over to the F0 menu. After shaft auto-tuning is complete, F7 is back to "0" automatically. If shaft auto-tuning conditions are not met, fault code "Err35" is displayed.

9. F8: test function

After you enter the F8 menu, the 7-segment LEDs display "0". The setting of F8 is described as follows:

- 1: Hall call forbidden
- 2: Door open forbidden
- 3: Overload forbidden
- 4: Limit switches disabled
- 6: Entering slip experiment state

After the setting is complete, press the SET button. Then the 7-segment LEDs display "Err88" and blink, prompting that the elevator is being tested. When you press PRG to exit, F8 is back to 0 automatically.

10. F9: reserved

11. FA: auto-tuning

After you enter the FA menu, the 7-segment LEDs display "0". The setting range of FA is 1 and 2, as follows:

- 1: With-load auto-tuning
- 2: No-load auto-tuning

After the setting is complete, press the SET button. Then the 7-segment LEDs display "TUNE", and the elevator enters the auto-tuning state. After confirming that the elevator meets the safe running conditions, press the SET button again to start auto-tuning.

After auto-tuning is complete, the 7-segment LEDs display the current angle for 2s, and then switch over to the F0 menu.

You can press the PRG button to exit the auto-tuning state.

12. Fb: CTB state display

After you enter the Fb menu, the 7-segment LEDs display the input/output state of the CTB. The following table describes the meaning of each segment of the LEDs.

Table 4-1 Input/Output state of the CTB

LED No.	Segment Mark	Meaning of Segment	Meaning of ON	Diagram
1	A	Light curtain 1	Light curtain 1 input active	
	B	Light curtain 2	Light curtain 2 input active	
	C	Door open limit 1	Door open limit 1 input active	
	D	Door open limit 2	Door open limit 2 input active	
	E	Door close limit 1	Door close limit 1 input active	
	F	Door close limit 2	Door close limit 2 input active	
	G	Full-load	Full-load input active	
DP	Overload	Overload input active		
2	A	Light-load	Light-load signal active	
3	A	Door open 1	Door open 1 relay output	
	B	Door close 1	Door close 1 relay output	
	C	Forced door close 1	Forced door close 1 relay output	
	D	Door open 2	Door open 2 relay output	
	E	Door close 2	Door close 2 relay output	
	F	Forced door close 2	Forced door close 2 relay output	
	G	Up arrival gong	Up arrival gong relay output	
	DP	Down arrival gong	Down arrival gong relay output	

13. FC: elevator direction change (same as the function of F2-10)

- 0: Direction unchanged
- 1: Direction reversed

4.2 Use of the LED Operation Panel

The LED operation panel is connected to the RJ45 interface of the controller by using an 8-core flat cable. You can modify the parameters, monitor the working status and start or stop the controller by operating the operation panel. The following figure shows the LED operation panel.

Figure 4-3 Diagram of the LED operation panel

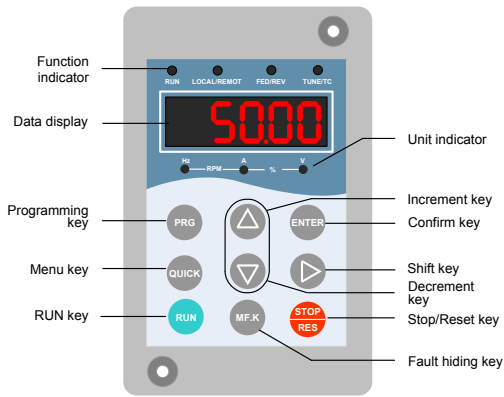

4.2.1 Description of Indicators

■ RUN

ON indicates that the controller is in the running state, and OFF indicates that the controller is in the stop state.

■ LOCAL/REMOT

Reserved.

■ FWD/REV

ON indicates up direction of the elevator, and OFF indicates down direction of the elevator.

■ TUNE/TC

ON indicates the auto-tuning state.

■ Unit Indicators

● means that the indicator is ON, and ○ means that the indicator is OFF.

●—RPM—○—%—○ Hz: unit of frequency

○—RPM—●—%—○ A: unit of current

○—RPM—○—%—● V: unit of voltage

●—RPM—●—%—○ RPM: unit of rotational speed

○—RPM—●—%—● %: percentage

4.2.2 Description of Keys on the Operation Panel

Table 4-2 Description of keys on the operation panel

Key	Name	Function
	Programming	Enter or exit Level-I menu.
	Confirm	Enter the menu interfaces level by level, and confirm the parameter setting.
	Increment	Increase data or function code.
	Decrement	Decrease data or function code.
	Shift	Select the displayed parameters in turn in the stop or running state, and select the digit to be modified when modifying parameters.
	Run	Start the controller in the operation panel control mode.
	Stop/Reset	Stop the controller when it is in the running state and perform the reset operation when it is in the fault state.
	Quick	Enter or exit Level-I quick menu.
	Fault hiding	Press this key to display or hide the fault information in the fault state, which facilitates parameter viewing.

4.2.3 Operation Procedure

The LED operation panel adopts three-level menu.

The three-level menu consists of function code group (Level I), function code (Level II), and function code setting value (level III), as shown in the following figure.

Figure 4-4 Operation procedure on the operation panel

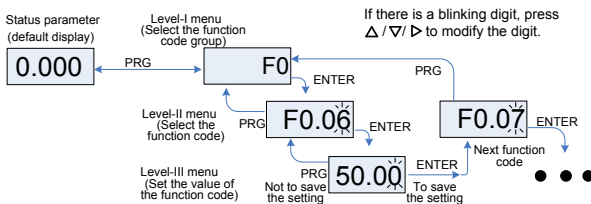

You can return to Level II menu from Level III menu by pressing **PRG** or **ENTER**. The difference between the two is as follows:

- After you press **ENTER**, the system saves the parameter setting first, and then goes back to Level II menu and shifts to the next function code.
- After you press **PRG**, the system does not save the parameter setting, but directly returns to Level II menu and remains at the current function code.

The following figure shows the shift between the three levels of menus.

Figure 4-5 Shift between the three levels of menus

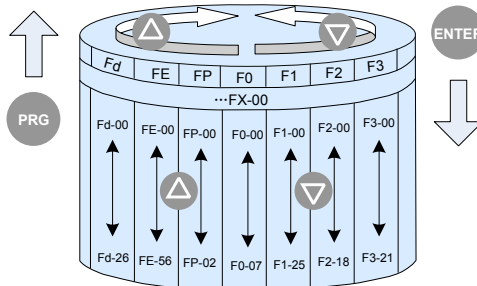

In Level III menu, if the parameter has no blinking digit, it means that the parameter cannot be modified. This may be because:

- Such a parameter is only readable, such as actually detected parameters and running record parameters.
- Such a parameter cannot be modified in the running state and can only be changed at stop.

4.2.4 Viewing Status Parameters

In the stop or running state, the operation panel can display multiple status parameters. Whether parameters are displayed is determined by the equivalent binary bits converted from the values of FA-01 and FA-02.

In the stop state, a total of 12 parameters can be displayed circularly by pressing **▶**. You can select the parameters to be displayed by setting FA-02 (each of the binary bits converted from the value of FA-02 indicates a parameter).

Figure 4-6 Shift between parameters displayed in the stop state

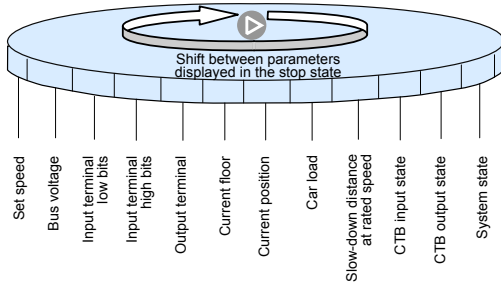

In the running state, a total of 16 parameters can be displayed circularly by pressing . You can select the parameters to be displayed by setting FA-01 (each of the binary bits converted from the value of FA-02 indicates a parameter).

Figure 4-7 Shift between parameters displayed in the running state



For details, see the description of corresponding parameters in Chapter 7.

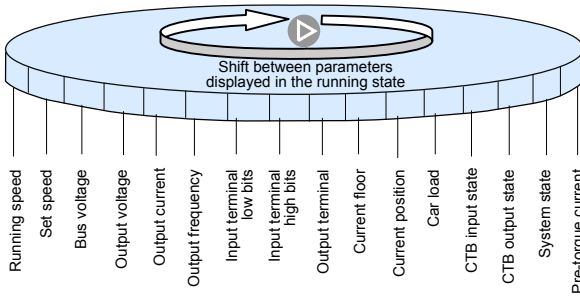

System Commissioning and Application Example

Chapter 5 System Commissioning and Application Example

5.1 System Commissioning

⚠ CAUTION

- Ensure that there is no person in the shaft or car before performing commissioning on the elevator.
- Ensure that the peripheral circuit and mechanical installation are ready before performing commissioning.

The following figure shows the commissioning procedure of the system.

Figure 5-1 Commissioning procedure of the system

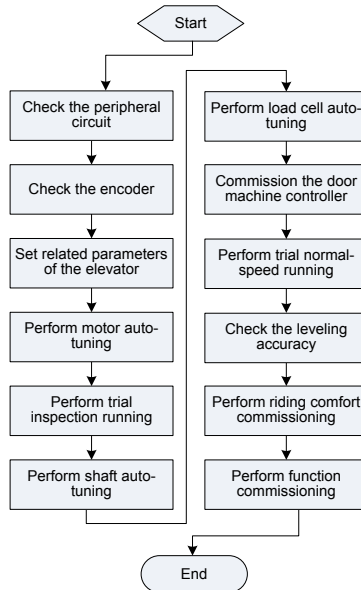

5.1.1 Check Before Commissioning

The elevator needs to be commissioned after being installed; the correct commissioning guarantees safe and normal running of the elevator. Before performing electric commissioning, check whether the electrical part and mechanical part are ready for commissioning to ensure safety.

At least two persons need to be onsite during commissioning so that the power supply can be cut off immediately when an abnormality occurs.

1. Check the field mechanical and electric wiring.

Before power-on, check the peripheral wiring to ensure component and personal safety.

The items to be checked include:

- 1) Whether the component models are matched
- 2) Whether the safety circuit is conducted and reliable
- 3) Whether the door lock circuit is conducted and reliable
- 4) Whether the shaft is unobstructed, and the car has no passenger and meets the conditions for safe running
- 5) Whether the cabinet and traction motor are well grounded
- 6) Whether the peripheral circuit is correctly wired according to the drawings of the vendor
- 7) Whether all switches act reliably
- 8) Whether there is short-circuit to ground by checking the inter-phase resistance of the main circuit
- 9) Whether the elevator is set to the inspection state
- 10) Whether the mechanical installation is complete (otherwise, it will result in equipment damage and personal injury)

2. Check the encoder.

The pulse signal from the encoder is critical to accurate control of the system. Before commissioning, check the following items carefully:

- 1) The encoder is installed reliably with correct wiring. For details on the encoder wiring, see section 3.5.
- 2) The signal cable and strong-current circuit of the encoder are laid in different ducts to prevent interference.
- 3) The encoder cable is preferably directly connected to the control cabinet. If the cable is not long enough and an extension cable is required, the extension cable must be a shielding cable and preferably welded to the original encoder cable by using the soldering iron.
- 4) The shielding cable of the encoder cable is grounded on the end connected to the controller (only one end is grounded to prevent interference).

3. Check the power supply before power-on.

- 1) The inter-phase voltage of the user power supply is within (380 V \pm 15%), and the unbalance degree does not exceed 3%.
- 2) The power input voltage between terminals 24V and COM on the MCB is within (24 VDC \pm 15%).
- 3) The total lead-in wire gauge and total switch capacity meet the requirements.

Note

If the input voltage exceeds the allowable value, serious damage will be caused. Distinguish the negative and positive of the DC power supply. Do not run the system when there is input power phase loss.

4. Check the grounding.

- 1) Check that the resistance between the following points and the ground is close to infinity.
 - R, S, T and PE
 - U, V, W and PE
 - 24V and PE on the MCB
 - Motor U, V, W and PE
 - +, – bus terminals and PE
 - Safety circuit, door lock circuit, and inspection circuit terminals and PE
- 2) Check the grounding terminals of all elevator electrical components and the power supply of the control cabinet

5.1.2 Setting and Auto-tuning of Motor Parameters

The NICE3000^{new} supports two major control modes, sensorless vector control (SVC) and closed-loop vector control (CLVC). SVC is applicable to inspection speed running for commissioning and fault judgment running during maintenance of the asynchronous motor. CLVC is applicable to normal elevator running. In CLVC mode, good driving performance and running efficiency can be achieved in the prerequisite of correct motor parameters.

■ Motor Parameters to Be Set

The motor parameters that need to be set are listed in the following table.

Table 5-1 Motor parameters to be set

Function Code	Parameter Name	Description
F1-25	Motor type	0: Asynchronous motor 1: Synchronous motor
F1-00	Encoder type	0: SIN/COS encoder, absolute encoder 1: UVW encoder 2: ABZ incremental encoder
F1-12	Encoder pulses per revolution	0–10000
F1-01 to F1-05	Rated motor power Rated motor voltage Rated motor current Rated motor frequency Rated motor rotational speed	These parameters are model dependent, and you need to manually input them according to the nameplate.
F0-00	Control mode	0: Sensorless vector control (SVC) 1: Closed-loop vector control (CLVC) 2: Voltage/Frequency (V/F) control

Function Code	Parameter Name	Description
F0-01	Command source selection	0: Operation panel control 1: Distance control
F1-11	Auto-tuning mode	0: No operation 1: With-load auto-tuning 2: No-load auto-tuning 3: Shaft auto-tuning

■ **Precautions for Motor Auto-tuning**

Follow the following precautions:

- Ensure that all wiring and installation meet the safety specifications.
- Ensure that the motor wiring is correct (UVW cables of the motor respectively connected to UVW cables of the controller) for with-load auto-tuning. If the motor wiring is incorrect, the motor may jitter or fail to run after the brake is released; in this case, you need to replace any two of the motor UVW cables.
- Reset the current fault and then start auto-tuning, because the system cannot enter the auto-tuning state ("TUNE" is not displayed) when there is a fault.
- Perform motor auto-tuning again if the phase sequence or encoder of the synchronous motor is changed.
- For the synchronous motor, perform three or more times of auto-tuning, compare the obtained values of F1-06 (Encoder initial angle). The value deviation of F1-06 shall be within $\pm 5^\circ$, which indicates that the auto-tuning is successful.
- After the auto-tuning is completed, perform trial inspection running. Check whether the current is normal, whether the actual running direction is the same as the set direction. If the running direction is different from the set direction, change the value of F2-10.
- With-load auto-tuning is dangerous (inspection-speed running of many control cabinets is emergency electric running and the shaft safety circuit is shorted). Ensure that there is no person in the shaft in this auto-tuning mode.

The following figure shows the motor auto-tuning process.

Figure 5-2 Motor auto-tuning process

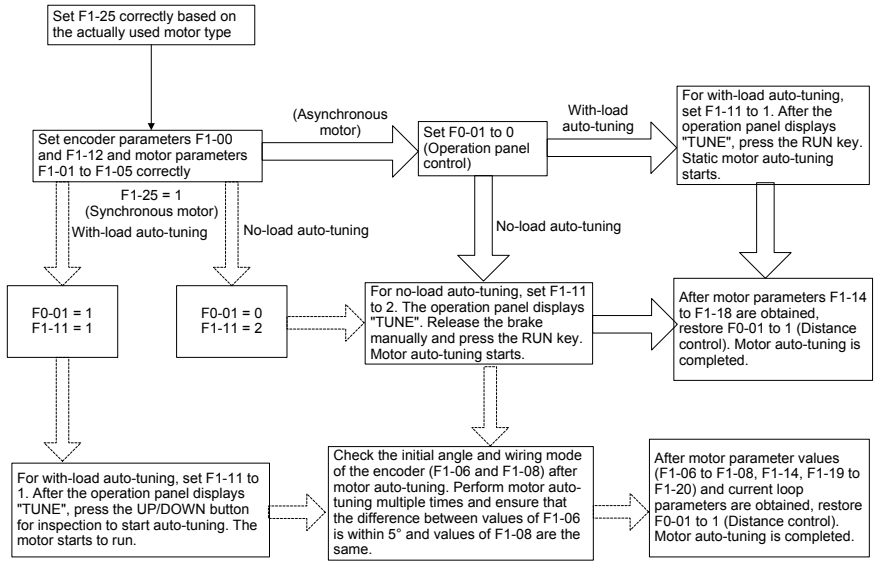

More descriptions of motor auto-tuning are as follows:

- When the NICE3000^{new} drives the synchronous motor, an encoder is required to provide feedback signals. You must set the encoder parameters correctly before performing motor auto-tuning.
- During synchronous motor auto-tuning, the motor needs to rotate. The best auto-tuning mode is no-load auto-tuning; if this mode is impossible, then try with-load auto-tuning.
- For synchronous motor, with-load auto-tuning learns stator resistance, shaft-D and shaft-Q inductance, current loop (including zero servo) PI parameters, and encoder initial angle; no-load auto-tuning additionally learns the encoder wiring mode.
- For the asynchronous motor, static auto-tuning learns stator resistance, rotor resistance, and leakage inductance, and automatically calculates the mutual inductance and motor magnetizing current. Complete auto-tuning learns the mutual inductance, motor magnetizing current, and current loop parameters are learned.

■ Output State of RUN and Brake Contactors

For the sake of safety in different control modes, the system handles the output commands to the RUN contactor or brake contactor differently. In some situations, it is necessary to release the RUN contactor or the brake contactor manually

The following table lists the output state of the running and brake contactors.

Table 5-2 Output state of the RUN and brake contactors

Control mode Output State	No-load Auto-tuning (F1-11 = 2)	With-load Auto-tuning (F1-11 = 1)		Operation Panel Control (F0-01 = 0)	Distance Control (F0-01 = 1)
		Synchronous motor	Asynchronous Motor		
RUN contactor	Output	Output	Output	Not output	Output
Brake contactor	Not output	Output	Not output	Not output	Output

5.1.3 Trial Running at Normal Speed

After ensuring that running at inspection speed is normal, perform shaft auto-tuning, and then you can perform trial running at normal speed (the elevator satisfies the safety running requirements).

To perform shaft auto-tuning, the following conditions must be satisfied:

1. The signals of the encoder and leveling sensors (NC, NO) are correct and the slow-down switches are installed properly and act correctly.
2. When the elevator is at the bottom floor, the down slow-down 1 switch acts.
3. The elevator is in the inspection state. The control mode is distance control and CLVC (F0-00 = 1, F0-01 = 1).
4. The top floor number (F6-00) and bottom floor number (F6-01) are set correctly.
5. The system is not in the fault alarm state. If there is a fault at the moment, press  to reset the fault.

Then set F1-11 to 3 on the operation panel or set F7 to 1 on the keypad of the MCB, and start shaft auto-tuning.

Note

For shaft auto-tuning when there are only two floors, the elevator needs to run to below the bottom leveling position, that is, the leveling sensor is disconnected from the leveling plate. There is no such requirement when there are multiple floors.

5.1.4 Door Machine Controller Commissioning

Correlation of the door machine controller and the elevator controller is that the CTB outputs door open/close command and the door machine controller feeds back the door open/close limit signal.

After commissioning and installation of the door machine controller are complete, check whether the wiring is correct and whether the door open/close limit signals are consistent with the default setting. To perform the door machine controller commissioning, do as follows:

1. In the terminal control mode of the door machine controller, manually short the door open relay output terminal BM/B1 and the door close relay output terminal BM/B2 on

the CTB, and observe whether the door machine can open and close correspondingly. If the door machine cannot act properly, check whether BM/B1 and BM/B2 are wrongly connected to the input terminals of the door machine controller and whether commissioning of the door machine controller is complete.

2. After ensuring that control of door open/close is normal, check whether the door open/close signal feedback from the door machine controller is normal.
 - a. Check the NO/NC states of the door input signals by observing the input indicators on the CTB, as listed in the following table.

Table 5-3 NO/NC state of the door input signals

Door State	Signal Input Point	NO Input Signal		NC Input Signal	
		Indicator State	F5-25 Setting	Indicator State	F5-25 Setting
Door open limit	X3 (door open limit 1)	When the signal is active, the corresponding input indicator is ON.	Bit2 = 1	When the signal is active, the corresponding input indicator is OFF.	Bit2 = 0
	X4 (door open limit 2)		Bit4 = 1		Bit4 = 0
Door close limit	X5 (door close limit 1)		Bit3 = 1		Bit3 = 0
	X6 (door close limit 2)		Bit5 = 1		Bit5 = 0

For details on the setting of F5-25, see the description of F5-25 in Chapter 7.

- b. Check whether the door open/close limit signal received by the system is correct.

As shown in the following figure which is part of display of parameter F5-35 on the operation panel, segments E and C of the upmost right 7-segment LED are the monitoring points of door open limit and door close limit.

- Segment C ON, segment E OFF: The system receives the door open limit signal and the door is in the open state.
- Segment E ON, segment C OFF: The system receives the door close limit signal and the door is in the close state.

The two segments should be OFF in the door open/close process.

Control the door to the open or close state manually and view the value of F5-35. If the following screen is displayed, it indicates that the door machine controller feeds back the correct door open and close signals.

Figure 5-3 Door open and close limit monitoring signals

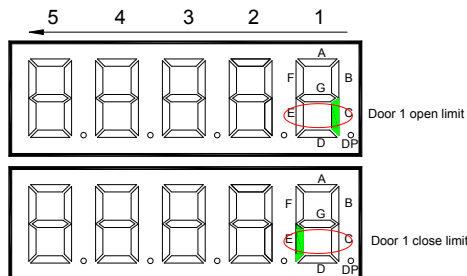

5.1.5 Riding Comfort

The riding comfort is an important factor of the elevator's overall performance. Improper installation of mechanical parts and improper parameter settings will cause discomfort. Enhancing the riding comfort mainly involves adjustment of the controller output and the elevator's mechanical construction.

■ Controller Output

The parameters that may influence the riding comfort are described in this part.

Function Code	Parameter Name	Setting Range	Default	Description
F1-09	Current filter time (synchronous motor)	0–3	0	It can reduce the lower-frequency vertical jitter during running.
F1-18	Magnetizing current	0.01–300.00	0.00 A	Increasing the value can improve the loading capacity of the asynchronous motor.
F2-00	Speed loop proportional gain KP1	0–100	40	F2-00 and F2-01 are the PI regulation parameters when the running frequency is lower than F2-02 (Switchover frequency 1). F2-03 and F2-04 are the PI regulation parameters when the running frequency is higher than F2-02 (Switchover frequency 2). The regulation parameters between F2-02 and F2-04 are the weighted average value of F2-00 & F2-01 and F2-03 & F2-04.
F2-01	Speed loop integral time T11	0.01–10.00s	0.60s	
F2-02	Switchover frequency 1	0.00 to F2-05	2.00 Hz	
F2-03	Speed loop proportional gain KP2	0–100	35	
F2-04	Speed loop integral time T12	0.01–10.00s	0.80s	
F2-05	Switchover frequency 2	F2-02 to F0-06	5.00 Hz	

For a faster system response, increase the proportional gain and reduce the integral time. Be aware that a fast system response causes system oscillation.

The recommended regulating method is as follows:

If the default setting cannot satisfy the requirements, make slight regulation. Increase the proportional gain first to the largest value under which the system does not oscillate. Then decrease the integral time to ensure fast responsiveness and small overshoot.

If both F2-02 (Switchover frequency 1) and F2-05 (Switchover frequency 2) are set to 0, only F2-03 and F2-04 are valid.

Function Code	Parameter Name	Setting Range	Default	Description
F2-06	Current loop proportional gain	10–500	60	F2-06 and F2-07 are the current loop adjustment parameters in the vector control algorithm.
F2-07	Current loop integral gain	10–500	30	

The optimum values of these two parameters are obtained during motor auto-tuning, and you need not modify them. Appropriate setting of the parameters can restrain jitter during running and have obvious effect on the riding comfort.

Function Code	Parameter Name	Setting Range	Default	Description
F2-18	Startup acceleration time	0.000–1.500s	0.000s	It can reduce the terrace feeling at startup caused by the breakout friction of the guide rail.
F3-00	Startup speed	0.000–0.030 m/s	0.000 m/s	
F3-01	Startup holding time	0.000–0.500s	0.000s	
F3-18	Zero-speed control time at startup	0.000–1.000s	0.200s	It specifies the zero speed holding time before brake output.
F3-19	Brake release delay	0.000–2.000s	0.200s 0.600s	It specifies the brake release time.
F3-20	Zero-speed control time at end	0.000–1.000s	0.300s	It specifies the zero speed holding time after the brake is applied.
F8-11	Brake apply delay	0.200–1.500s	0.200s	It specifies the brake apply time.

Figure 5-4 Running time sequence

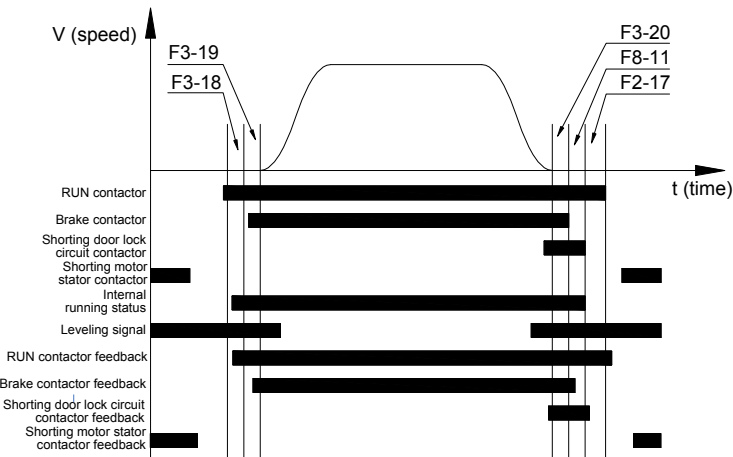

F3-18 (Zero-speed control time at startup) specifies the time from output of the RUN contactor to output of the brake contactor, during which the controller performs excitation on the motor and outputs zero-speed current with large startup torque.

F3-19 (Brake release delay) specifies the time from the moment when the system sends the brake release command to the moment when the brake is completely released, during which the system retains the zero-speed torque current output.

F3-20 (Zero-speed control time at end) specifies the zero-speed output time when the running curve ends.

F8-11 (Brake apply delay) specifies the time from the moment when the system sends the brake apply command to the moment when the brake is completely applied, during which the system retains the zero-speed torque current output.

The release time of the brakes varies according to the types and the response time of the brakes is greatly influenced by the ambient temperature. A high brake coil temperature slows the brake responsiveness. Thus, when the riding comfort at startup or stop cannot be improved by adjusting zero servo or load cell compensation parameters, appropriately increase the values of F3-19 and F8-11 to check whether the brake release time influences the riding comfort.

Function Code	Parameter Name	Setting Range	Default	Remarks
F8-01	Pre-torque selection	0: Pre-torque invalid 1: Load cell pre-torque compensation 2: Automatic pre-torque compensation	0	Set this parameter based on actual requirement.
F2-11	Zero servo current coefficient	0.20–50.0	15.0	These are zero-servo regulating parameters when F8-01 is set to 2 (Automatic pre-torque compensation).
F2-12	Zero servo speed loop KP	0.00–2.00	0.50	
F2-13	Zero servo speed loop KI	0.00–2.00	0.60	

When F8-01 is set to 2 (Automatic pre-torque compensation), the system automatically adjusts the compensated torque at startup.

- a. Gradually increase F2-11 (Zero servo current coefficient) until that the rollback is cancelled at brake release and the motor does not vibrate.
- b. Decrease the value of F2-11 (Zero servo current coefficient) if the motor jitters when F2-13 (Zero servo speed loop TI) is less than 1.00.
- c. Motor vibration and acoustic noise indicate excessive value of F2-12 (Zero servo speed loop KP). Decrease the default value of F2-12.
- d. If the motor noise is large at no-load-cell startup, decrease the value of F2-12 or F2-13.

Function Code	Parameter Name	Setting Range	Default	Remarks
F8-02	Pre-torque offset	0.0%–100.0%	50.0%	These are pre-torque regulating parameters.
F8-03	Drive gain	0.00–2.00	0.60	
F8-04	Brake gain	0.00–2.00	0.60	

When F8-01 is set to 1 (Load cell pre-torque compensation), the system with a load cell pre-outputs the torque matched the load to ensure the riding comfort of the elevator.

- Motor driving state: full-load up, no-load down
- Motor braking state: full-load down, no-load up

F8-02 (Pre-torque offset) is actually the elevator balance coefficient, namely, the percentage of the car load to the rated load when the car and counterweight are balanced.

F8-03 (Drive gain) or F8-04 (Brake gain) scales the elevator's present pre-torque coefficient when the motor runs at the drive or brake side. If the gain set is higher, then the calculated value of startup pro-torque compensation is higher. The controller identifies the braking or driving state according to the load cell signal and automatically calculates the required torque compensation value.

When an analog device is used to measure the load, these parameters are used to adjust the elevator startup. The method of adjusting the startup is as follows:

- In the driving state, increasing the value of F8-03 could reduce the rollback during the elevator startup, but a very high value could cause car lurch at start.
- In the braking state, increasing the value of F8-04 could reduce the jerk in command direction during the elevator startup, but a very high value could cause car lurch at start.

■ Mechanical Construction

The mechanical construction affecting the riding comfort involves installation of the guide rail, guide shoe, steel rope, and brake, balance of the car, and the resonance caused by the car, guide rail and motor. For asynchronous motor, abrasion or improper installation of the gearbox may arouse poor riding comfort.

1. Installation of the guide rail mainly involves the verticality and surface flatness of the guide rail, smoothness of the guide rail connection and parallelism between two guide rails (including guide rails on the counterweight side).
2. Tightness of the guide shoes (including the one on the counterweight side) also influences the riding comfort. The guide shoes must not be too loose or tight.
3. The drive from the motor to the car totally depends on the steel rope. Large flexibility of the steel rope with irregular resistance during the car running may cause curly oscillation of the car. In addition, unbalanced stress of multiple steel ropes may cause the car to jitter during running.
4. The riding comfort during running may be influenced if the brake arm is installed too tightly or released incompletely.
5. If the car weight is unbalanced, it will cause uneven stress of the guide shoes that connect the car and the guide rail. As a result, the guide shoes will rub with the guide rail during running, affecting the riding comfort.
6. For asynchronous motor, abrasion or improper installation of the gearbox may also affect the riding comfort.
7. Resonance is an inherent character of a physical system, related to the material and quality of system components. If you are sure that the oscillation is caused by resonance, reduce the resonance by increasing or decreasing the car weight or counterweight and adding resonance absorbers at connections of the components (for example, place rubber blanket under the motor).

5.1.6 Password Setting

The NICE3000^{new} provides the parameter password protection function. Here gives an example of changing the password into 12345 (indicates the blinking digit), as shown in the following figure.

Figure 5-5 Example of changing the password

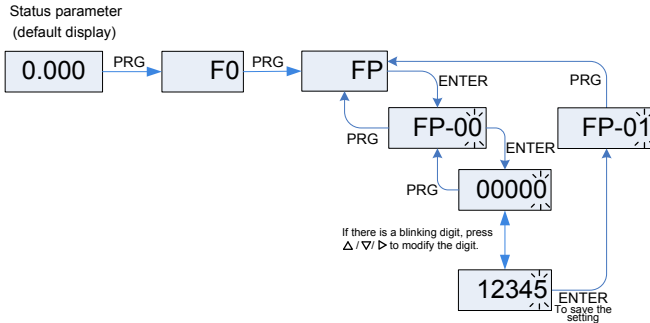

- After you set the user password (set FP-00 to a non-zero value), the system requires user password authentication (the system displays "-----") when you press PRG. In this case, you can modify the function code parameters only after entering the password correctly.
- For factory parameters (group FF), you also need to enter the factory password.
- Do not try to modify the factory parameters. If these parameters are set improperly, the system may be unstable or abnormal.
- In the password protection unlocked state, you can change the password at any time. The last input number will be the user password.
- If you want to disable the password protection function, enter the correct password and then set FP-00 to 0. If FP-00 is a non-zero value at power-on, the parameters are protected by the password.
- Remember the password you set. Otherwise, the system cannot be unlocked.

5.2 System Application

5.2.1 Emergency Evacuation at Power Failure

Passengers may be trapped in the car if power failure suddenly happens during the use of the elevator. The emergency evacuation function at power failure is designed to solve the problem.

The emergency evacuation function is implemented in the following two modes:

- Uninterrupted power supply (UPS)
- Emergency automatic rescue device (ARD) power supply
- Shorting PMSM stator

The three modes are described in detailed in the following part.

■ Emergency 220 V UPS

In this scheme, the 220 V UPS provides power supply to the main unit and the drive control circuit. The following figure shows the emergency 220 V UPS circuit.

Figure 5-6 Emergency 220 V UPS circuit

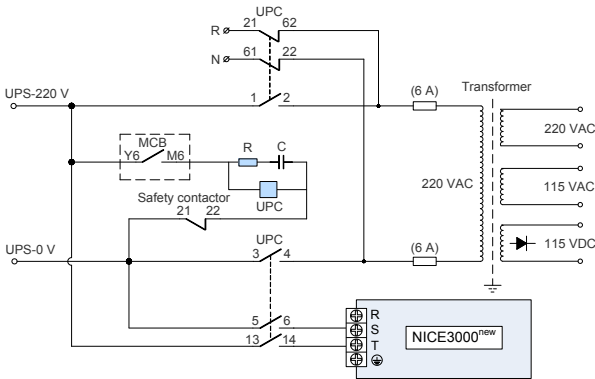

Note

The UPS emergency evacuation signal can be output only by Y6.

The following figure shows various contacts of the contactors.

Figure 5-7 Various contacts of the contactors

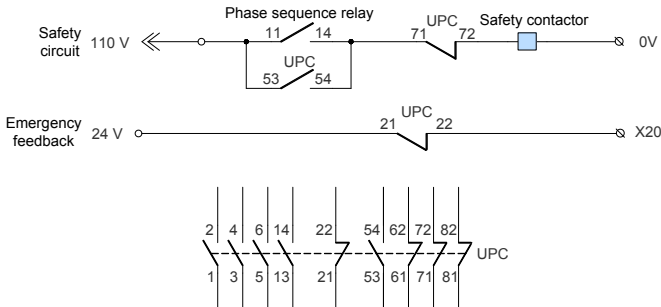

The UPS power is recommended in the following table.

Table 5-4 Recommended UPS power for each power class

UPS Power	Controller Power
1 kVA (700–800 W)	$P \leq 5.5 \text{ kW}$
2 kVA (1400–1600 W)	$5.5 \text{ kW} < P \leq 11 \text{ kW}$
3 kVA (2100–2400 W)	$15 \text{ kW} \leq P \leq 22 \text{ kW}$

The following table lists the setting of the related parameters.

Table 5-5 Parameter setting under the 220 V UPS scheme

Function Code	Parameter Name	Setting Range
F6-48	Emergency evacuation switching speed	0.010–0.630 m/s
F6-49	Evacuation parking floor	0 to F6-01
F8-09	Emergency evacuation operation speed at power failure	0.05 m/s
F8-10	Emergency evacuation operation mode at power failure	0: Invalid 1: UPS 2: 48 V battery power supply
F5-20 (X20)	X20 function selection	59 (UPS valid signal)
F5-31 (Y6)	Y6 function selection	13 (Emergency evacuation automatic switchover)

■ Emergency ARD Power Supply

In this scheme, the ARD supplies power to the main circuit and control circuit. The following figure shows the schematic diagram.

Figure 5-8 Three-phase emergency ARD power supply

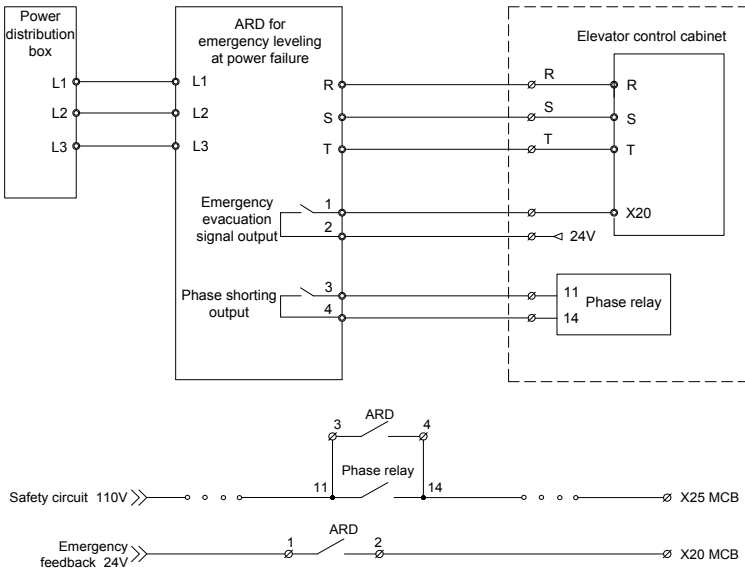
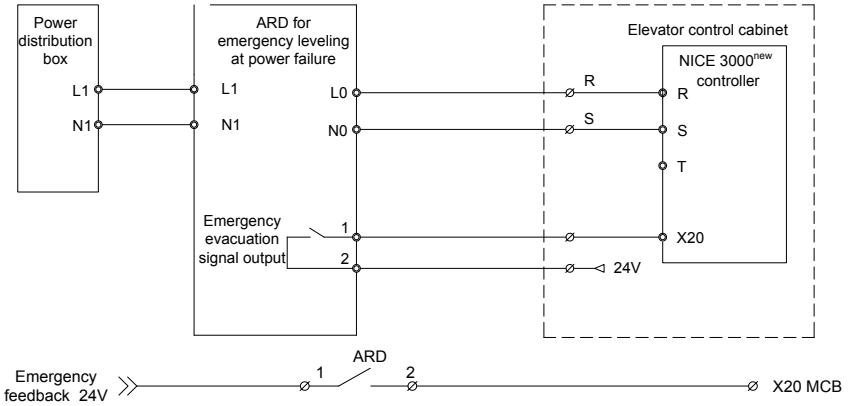

Figure 5-9 Single-phase emergency ARD power supply



The related configuration and description is as follows:

Select the ARD with the nominal output power equal to or larger than the rated motor power.

Monarch 380V ARD outputs the single-phase emergency voltage between the R and T phases to the control cabinet. Note that for ARDs of other brands, the phases that output the emergency voltage may be different.

Table 5-6 Parameter setting under the ARD scheme

Function Code	Parameter Name	Setting Range
F6-48	Emergency evacuation switching speed	0.010–0.630 m/s
F6-49	Evacuation parking floor	0 to F6-01
F8-09	Emergency evacuation operation speed at power failure	0.05 m/s
F8-10	Emergency evacuation operation mode at power failure	0: Invalid 1: UPS
F5-20 (X20)	X20 function selection	27 (UPS valid signal NO)

■ Shorting PMSM Stator

Shorting PMSM stator means shorting phases UVW of the PMSM, which produces resistance to restrict movement of the elevator car. In field application, an auxiliary NC contact is usually added to the NO contact of the output contactor to short PMSM UVW phases to achieve the effect. It is feasible in theory but may cause over-current actually. Due to the poor quality of the contactor and the wiring of adding the auxiliary contact, the residual current of the controller is still high when the outputs UVW are shorted at abnormal stop. This results in an over-current fault and may damage the controller or motor.

Monarch's shorting PMSM stator scheme requires the installation of an independent contactor for shorting PMSM stator. The shorting PMSM stator function is implemented via the relay NC contact. On the coil circuit of the RUN contactor, an NO contact of the shorting PMSM stator contactor is connected in serial, to ensure that output short-circuit does not occur when the parameter setting is incorrect.

The following figure shows wiring of the independent shorting PMSM stator contactor.

Figure 5-10 Wiring of the independent shorting PMSM stator contactor

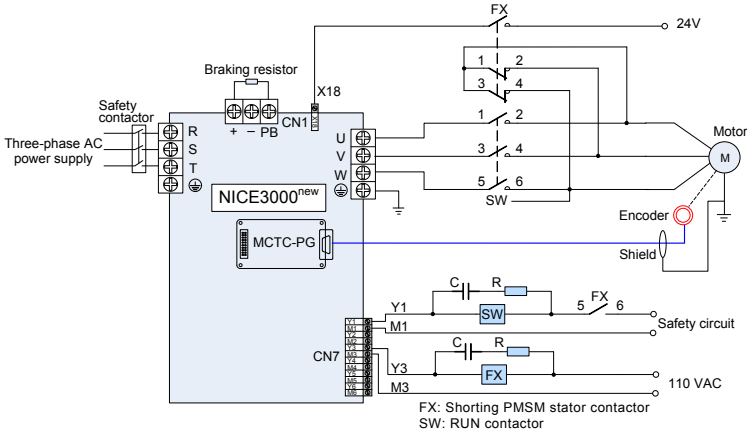

The parameter setting in such wiring mode is described in the following table.

Table 5-7 Parameter setting under the shorting PMSM stator scheme

Function Code	Parameter Name	Value	Description
F5-18	X18 function selection	30	Allocate X18 with "Input of shorting PMSM stator feedback signal".
F5-28	Y3 function selection	12	Allocate Y3 with "Output of shorting PMSM stator contactor feedback signal".
FE-33	Elevator function selection 2	-	Bit8 = 0: NC output contactor Bit8 = 1: NO output contactor

More details on the emergency evacuation setting are provided in F6-45, as listed in the following table.

Table 5-8 Parameter description of F6-45

Bit	Function Description	Binary Setting				Remarks
Bit0	Direction determine mode	0	Automatically calculating the direction	0	1	Direction of nearest landing floor If the torque direction is automatically calculated, the no-load-cell function must be enabled, that is, F8-01 is set to 2.
Bit1		0		1		
Bit2	Stop position	1	Stop at the base floor			-
		0	Stop at nearest landing floor			-

Bit	Function Description	Binary Setting		Remarks
Bit4	Startup compensation	1	Startup torque compensation valid in emergency evacuation running	When it is set that the torque direction is automatically calculated, enable automatic startup torque compensation.
Bit8	Emergency evacuation running time protection	1	If the elevator does not arrive at the required floor after 50s emergency evacuation running time, Err31 is reported.	This function is invalid when the function of switching over shorting stator braking mode to controller drive is used.
Bit10	Emergency buzzer output	1	The buzzer output is active during UPS emergency evacuation running.	-
Bit11	Reserved	0	-	-
Bit12	Shorting stator braking mode switched over to controller drive	1	Enable the function of switching over the shorting stator braking mode to controller drive.	-
Bit13	Mode of shorting stator braking mode switched over to controller drive	1	Speed setting	If the speed is still lower than the value set in F6-48 after the elevator is in shorting stator braking mode for 10s, the controller starts to drive the elevator.
		0	Time setting	If the time of the shorting stator braking mode exceeds 50s, the controller starts to drive the elevator.
Bit14	Emergency evacuation exit mode	1	Exit at door close limit	-
		0	Exit at door open limit	-
Bit15	Function selection of shorting stator braking mode	1	Enable this function.	When this function is enabled, the setting of related function codes becomes effective.

5.2.2 Parallel Control of Two Elevators

The NICE3000^{new} supports parallel control of two elevators, which is implemented by using the CANbus communication port for information exchange and processing between the two elevators. The NICE3000^{new} also supports group control of three to eight elevators if a group control board is used. This implements coordination between multiple elevators to respond to hall calls and improves the elevator use efficiency.

The NICE3000^{new} is compatible with the NICE3000 and NICE5000. This section describes the use of two elevators in parallel control. For use of multiple elevators in group control, refer to the description of the group control board or contact Monarch.

■ Communication Ports for Parallel Control

The following table lists the parameter setting of parallel control.

Table 5-9 Parameter setting of parallel control by means of communication ports

Function Code	Parameter Name	Setting Range	Setting in Parallel Control
F6-07	Number of elevators in parallel/group mode	1–8	2
F6-08	Elevator No.	1–8	Master elevator: 1 Slave elevator: 2
F6-09	Program control selection 2	Bit3: Parallel/Group control implemented at CAN2	Bit3 = 1 when CN4 of the CAN2 communication port is used for parallel/group control
		Bit4: Group control in compatibility with NICE3000	Bit4 = 1 when the NICE3000 is involved in group control

Note

By default, the CAN1 communication port is used for parallel control by default. Therefore, you need not select the parallel control port.

When the CAN2 communication port is used for parallel control, you need not set the CTB address switch.

■ Parallel Control by Using CAN1 (Terminal CN3)

When the CAN1 communication port (CN3 terminal) is used for parallel control, you need to set the CTB addresses, according to the following table.

Table 5-10 Address and jumper setting of the CTB for CAN1 is used for parallel control



CTB	Jumper Setting	Description
CTB of elevator 1#	 J2	Short J2 at the OFF position or do not connect it. Set the CTB as the master when setting the address.
CTB of elevator 2#	 J2	Short J2 at the ON position or do not connect it. Set the CTB as the slave when setting the address.

Figure 5-11 Wiring when CAN1 is used for parallel control



■ Parallel Control by Using CAN2 (Terminal CN4)

This mode can be implemented by directly connecting the CN4 terminals of two elevators and setting related parameters of group F6. You need not set the CTB addresses.

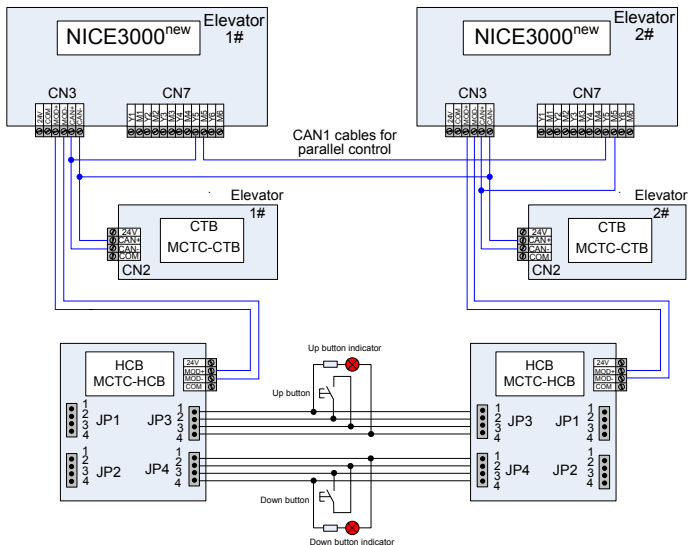
Figure 5-12 Wiring when CAN2 is used for parallel control

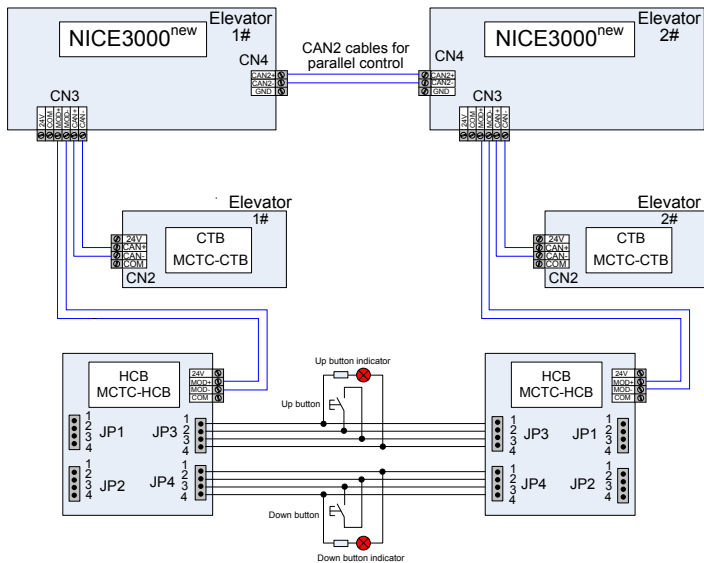

■ **Address Setting of Physical Floors**

Physical floors, relative to the NICE control system, are defined by the installation position of the leveling plate. The floor (such as the ground floor) at which the lowest leveling plate is installed corresponds to physical floor 1. The top physical floor is the accumulative number of the leveling plates. In parallel mode, the physical floor numbers of the same floor for two elevators are consistent.

If the floor structures of two elevators are different, physical floors should start with the floor with the lowest position. The physical floors at the overlapped area of the two elevators are the same. Even if one elevator does not stop a floor in the overlapped area, a leveling plate should be installed there. You can make the elevator not stop at the floor by setting service floors.

When two elevators are in parallel mode, the addresses of the HCBs should be set according to physical floors. Parallel running can be implemented only when the HCB address set for one elevator is the same as that for the other elevator in terms of the same floor.

Note

In parallel mode, the top floor (F6-00) and bottom floor (F6-01) of the elevators should be set based on corresponding physical floors.

Assume that there are two elevators in parallel mode. Elevator 1 stops at floor B1, floor 1, floor 2, and floor 3, while elevator 2 stops at floor 1, floor 3, and floor 4. Now, you need to set related parameters and HCB addresses according to the following table.

Table 5-11 Parameter setting and HCB addresses of two elevators

		Elevator 1		Elevator 2	
Number of elevators in parallel/group mode (F6-07)		2		2	
Elevator No. (F6-08)		1		2	
Actual floor	Physical floor	HCB address	HCB display	HCB address	HCB display
B1	1	1	FE-01 = 1101		
1	2	2	FE-02 = 1901	2	FE-02 = 1901
2	3	3	FE-03 = 1902	Non-stop floor but leveling plate required	FE-03 = 1902
3	4	4	FE-04 = 1903	4	FE-04 = 1903
4	5			5	FE-05 = 1904
Bottom floor (F6-01)		1		2	
Top floor (F6-00)		4		5	
Service floor (F6-05)		65535		65531 (not stop at physical floor 3)	

5.2.3 Opposite Door Control

The NICE3000^{new} supports four opposite door control modes: mode 1, mode 2, mode 3, and mode 4, which are implemented by using two methods set in Bit15 of FE-33.

Method A: Same as that of NICE3000

Method B: New method, completely different from that of NICE3000

1. Control modes and related parameter setting.

Table 5-12 Opposite door control modes and parameter setting

Opposite Door Control Mode	Parameter Setting	Function Description	Use Method
Method A (same as the NICE3000) FE-33 Bit15 = 1			
Mode 1	FE-33 Bit15 = 1; Fb-00 = 2	FC-04 = 0 (Simultaneous control)	The hall call addresses of the front door are set based on floor (1–15). The hall call addresses of the back door are set based on floor +16 (17–31). A maximum of 15 floors are supported.
Mode 2		FC-04 = 1 (Hall call independent, car call simultaneous)	
Mode 3		FC-04 = 2 (Hall call independent, car call manual control)	
Mode 4		FC-04 = 3 (Hall call independent, car call independent)	

Opposite Door Control Mode	Parameter Setting		Function Description	Use Method
Method B FE-33 Bit15 = 0 (default)				
Mode 1	Fb-00 = 2 F8-16 = N (N > current top floor)	FC-04 = 0 (Simultaneous control)	The front door and back door act simultaneously upon arrival for hall calls and car calls.	The hall call addresses of the front door are set based on floor (1-N). The hall call addresses of the back door are set based on floor (N+1 to N+20). A maximum of 20 floors are supported.
Mode 2		FC-04 = 1 (Hall call independent, car call simultaneous)	The corresponding door opens upon arrival for hall calls from this door. The front door and back door act simultaneously upon arrival for car calls.	
Mode 3		FC-04 = 2 (Hall call independent, car call manual control)	The corresponding door opens upon arrival for halls call from this door. Upon arrival for car calls, the door to open is selected between the front door and back door by using the door switchover switch. The door switchover signal is input from JP16 or JP20 of the CCB.	
Mode 4		FC-04 = 3 (Hall call independent, car call independent)	The corresponding door opens upon arrival for halls call and car calls from this door.	

Note

In the fire emergency and elevator lock state, the opposite door is under simultaneous control rather than independent control.

2. CCB wiring for opposite door control

The CCB wiring for modes 1, 2, and 3 either implemented in method A or B is the same, as shown in the following figures.

Figure 5-13 CCB wiring for modes 1, 2, and 3 (single operation box)

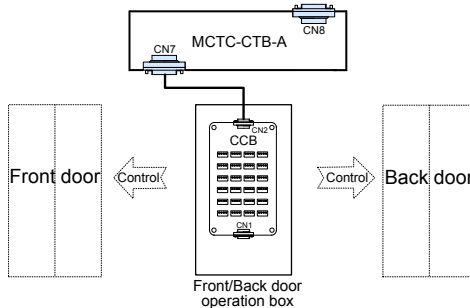
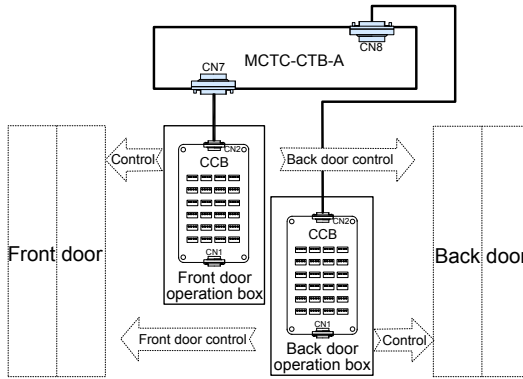

Figure 5-14 CCB wiring for modes 1, 2, and 3 (dual operation boxes)



For mode 4, The CCB wiring is different for method A and method B, as shown in the following figures.

Figure 5-15 CCB wiring for mode 4 (implemented in method A)

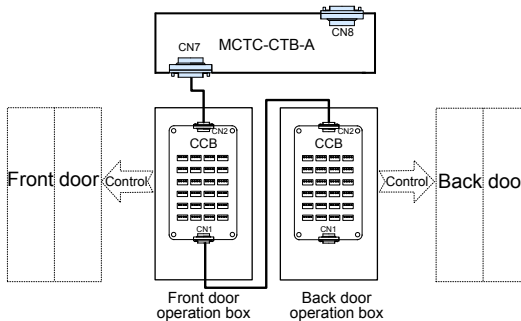
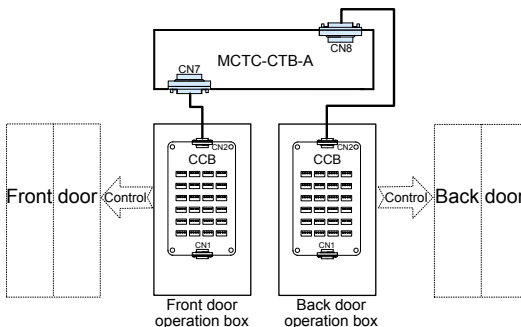

Figure 5-16 CCB wiring for mode 4 (implemented in method B)



3. HCB wiring and address setting

Figure 5-17 HCB wiring and address setting of method A

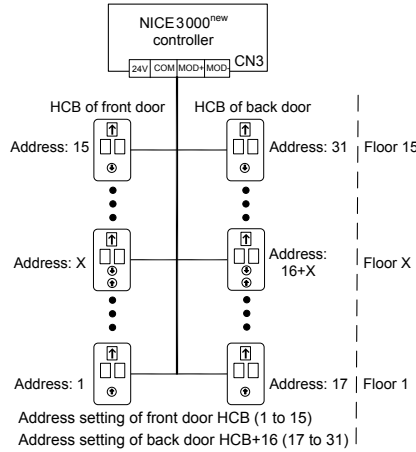
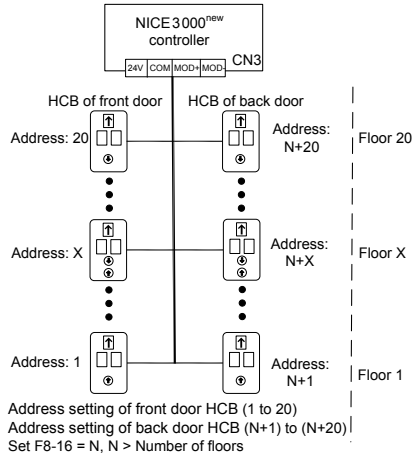

Figure 5-18 HCB wiring and address setting of method B



5.2.4 VIP Function Description

The NICE3000^{new} provides the VIP function that the elevator first directly runs to the VIP floor and provides services for special persons. After the system enters the VIP state, current car calls and halls are cleared; door open or close needs to be controlled manually; the elevator does not respond to hall calls.

Here gives an example to explain how to use the VIP function and set the VIP floor.

Assume that there are floors 1 to 20 for the elevator, and floor 8 is set as the VIP floor.

Table 5-13 Parameter setting of the VIP function

Function Code	Parameter Name	Setting Range	Value	Remarks
F6-00	Top floor of the elevator	F6-01 to 40	20	They are used to set the top floor and bottom floor of the elevator, determined by the number of actually installed leveling plates.
F6-01	Bottom floor of the elevator	1 to F6-00	1	
F6-12	VIP floor	0 to F6-00	8	Set floor 8 as the VIP floor.
FE-32	Elevator function selection 1	Bit9: VIP function	Bit9 = 1	The VIP service is enabled.
Fd-07	HCB:JP1 input	0: Reserved NO/NC input: 1/33: Elevator lock signal 2/34: Fire emergency signal 3/35: Current floor forbidden	4	These parameters are used to set the functions of pins 2 and 3 of JP1 and JP2 on the HCB. The setting is effective to the HCBs for all floors.
Fd-08	HCB:JP2 input	4/36: VIP floor signal 5/37: Security floor signal 6/38: Door close button input	4	
F6-46	VIP function selection	Bit0: VIP enabled by hall call (at VIP floor)	Bit0 = 1	The VIP function is enabled at a hall call.
		Bit1: VIP enabled by terminal	Bit1 = 1	After the hall call input for the VIP function is active, the system enters the VIP state.
		Bit2 to Bit7: Reserved	-	-
		Bit8: Number of VIP car calls limited	Bit8 = 1	If this function is enabled, only one car call is supported in the VIP state.

When there is a hall call at the VIP floor, the system automatically enters the VIP state. After the VIP input terminal is ON, the elevator returns to the VIP floor to provide the VIP service.

The VIP running times is limited by Bit8 of F6-46. If Bit8 is set to 1, the elevator responds to only one car call (the last one); after arriving at the floor required by the car call, the elevator automatically exits the VIP state. If Bit8 is set to 0, the number of car calls is not limited. The elevator automatically exits the VIP state if it does not enter the car call running within 30s after each time stop or after it executes all car calls. If there is no car call 30s after the elevator enters the VIP state, the elevator automatically exits the VIP state.



Function Code Table

Chapter 6 Function Code Table

6.1 Function Code Description

- There are a total of 18 function code groups, each of which includes several function codes. The function codes adopt the three-level menu. The function code group number is Level-I menu; the function code number is Level-II menu; the function code setting is Level-III menu.
- The meaning of each column in the function code table is as follows:

Function Code	Indicates the function code number.
Parameter Name	Indicates the parameter name of the function code.
Setting Range	Indicates the setting range of the parameter.
Default	Indicates the default setting of the parameter at factory.
Unit	Indicates the measurement unit of the parameter.
Property	Indicates whether the parameter can be modified (including the modification conditions)

The modification property of the parameters includes three types, described as follows:



" ☆ ": The parameter can be modified when the controller is in either stop or running state.

" ★ ": The parameter cannot be modified when the controller is in the running state.

" ● ": The parameter is the actually measured value and cannot be modified.

The system automatically restricts the modification property of all parameters to prevent mal-function.

6.2 Function Code Groups

On the operation panel, press  and then  or  , and you can view the function code groups. The function code groups are classified as follows:

F0	Basic parameters	F9	Time parameters
F1	Motor parameters	FA	Keypad setting parameters
F2	Vector control parameters	Fb	Door function parameters
F3	Running control parameters	FC	Protection function parameters
F4	Floor parameters	Fd	Communication parameters
F5	Terminal function parameters	FE	Elevator function parameters
F6	Basic elevator parameters	FF	Factory parameters
F7	Test function parameters	FP	User parameters
F8	Enhanced function parameters	Fr	Leveling adjustment parameters

6.3 Function Code Table

Function Code	Parameter Name	Setting Range	Default	Unit	Property
Group F0: Basic parameters					
F0-00	Control mode	0: Sensorless vector control (SVC) 1: Closed-loop vector control (CLVC) 2: Voltage/Frequency (V/F) control	1	-	★
F0-01	Command source selection	0: Operation panel control 1: Distance control	1	-	★
F0-02	Running speed under operation panel control	0.050 to F0-04	0.050	m/s	☆
F0-03	Maximum running speed	0.100 to F0-04	1.600	m/s	★
F0-04	Rated elevator speed	0.250–4.000	1.600	m/s	★
F0-05	Rated elevator load	300–9999	1000	kg	★
F0-06	Maximum frequency	20.00–99.00	50.00	Hz	★
F0-07	Carrier frequency	0.5–16.0	6.0	kHz	★
Group F1: Motor parameters					
F1-00	Encoder type	0: SIN/COS encoder, absolute encoder 1: UVW encoder 2: ABZ incremental encoder	0	-	★
F1-01	Rated motor power	0.7–75.0	Model dependent	kW	★
F1-02	Rated motor voltage	0–600	Model dependent	V	★

Function Code	Parameter Name	Setting Range	Default	Unit	Property
F1-03	Rated motor current	0.00–655.00	Model dependent	A	★
F1-04	Rated motor frequency	0.00–99.00	Model dependent	Hz	★
F1-05	Rated motor rotational speed	0–3000	Model dependent	RPM	★
F1-06	Encoder initial angle (synchronous motor)	0.0–359.9	0	Degree (°)	★
F1-07	Encoder angle at power-off (synchronous motor)	0.0–359.9	0	Degree (°)	★
F1-08	Synchronous motor wiring mode	0–15	0	-	★
F1-09	Current filter time (synchronous motor)	0–3	0	-	★
F1-10	Encoder verification selection	0–65535	0	-	★
F1-11	Auto-tuning mode	0: No operation 1: With-load auto-tuning 2: No-load auto-tuning 3: Shaft auto-tuning	0	-	★
F1-12	Encoder pulses per revolution	0–10000	2048	PPR	★
F1-13	Encoder wire-breaking detection time	0–10.0	1.0	s	★
F1-14	Stator resistance (asynchronous motor)	0.000–30.000	Model dependent	Ω	★
F1-15	Rotor resistance (asynchronous motor)	0.000–30.000	Model dependent	Ω	★
F1-16	Leakage inductance (asynchronous motor)	0.00–300.00	Model dependent	mH	★
F1-17	Mutual inductance (asynchronous motor)	0.1–3000.0	Model dependent	mH	★
F1-18	Magnetizing current (asynchronous motor)	0.01–300.00	Model dependent	A	★
F1-19	Shaft Q inductance (torque)	0.00–650.00	3.00	mH	★
F1-20	Shaft D inductance (excitation)	0.00–650.00	3.00	mH	★
F1-21	Back EMF	0–65535	0	-	★
F1-25	Motor type	0: Asynchronous motor 1: Synchronous motor	1	-	★

Function Code	Parameter Name	Setting Range	Default	Unit	Property
Group F2: Vector control parameters					
F2-00	Speed loop proportional gain KP1	0–100	40	-	★
F2-01	Speed loop integral time TI1	0.01–10.00	0.60	s	★
F2-02	Switchover frequency 1	0.00 to F2-05	2.00	Hz	★
F2-03	Speed loop proportional gain KP2	0–100	35	-	★
F2-04	Speed loop integral time TI2	0.01–10.00	0.80	s	★
F2-05	Switchover frequency 2	F2-02 to F0-06	5.00	Hz	★
F2-06	Current loop KP1 (torque)	10–500	60	-	★
F2-07	Current loop KI1 (torque)	10–500	30	-	★
F2-08	Torque upper limit	0.0–200.0	150.0	%	★
F2-10	Elevator running direction	0: Direction unchanged 1: Direction reversed	0	-	★
F2-11	Zero servo current coefficient	0.20–50.0	15	-	★
F2-12	Zero servo speed loop KP	0.00–2.00	0.5	-	★
F2-13	Zero servo speed loop KI	0.00–2.00	0.6	-	★
F2-16	Torque acceleration time	1–500	1	ms	★
F2-17	Torque deceleration time	1–500	350	ms	★
F2-18	Startup acceleration time	0.000–1.500	0.000	s	★
Group F3: Running control parameters					
F3-00	Startup speed	0.000–0.030	0.000	m/s	★
F3-01	Startup holding time	0.000–0.500	0.000	s	★
F3-02	Acceleration rate	0.200–1.500	0.600	m/s ²	★
F3-03	Acceleration start jerk time	0.300–4.000	2.500	s	★
F3-04	Acceleration end jerk time	0.300–4.000	2.500	s	★
F3-05	Deceleration rate	0.200–1.500	0.600	m/s ²	★

Function Code	Parameter Name	Setting Range	Default	Unit	Property
F3-06	Deceleration end jerk time	0.300–4.000	2.500	s	★
F3-07	Deceleration start jerk time	0.300–4.000	2.500	s	★
F3-08	Special deceleration rate	0.200–1.500	0.900	m/s ²	★
F3-09	Pre-deceleration distance	0–90.0	0.0	mm	★
F3-10	Re-leveling speed	0.000–0.080	0.040	m/s	★
F3-11	Inspection speed	0.100–0.630	0.250	m/s	★
F3-12	Position of up slow-down 1	0.000–300.00	0.00	m	★
F3-13	Position of down slow-down 1	0.000–300.00	0.00	m	★
F3-14	Position of up slow-down 2	0.000–300.00	0.00	m	★
F3-15	Position of down slow-down 2	0.000–300.00	0.00	m	★
F3-16	Position of up slow-down 3	0.000–300.00	0.00	m	★
F3-17	Position of down slow-down 3	0.000–300.00	0.00	m	★
F3-18	Zero-speed control time at startup	0.000–1.000	0.200	s	★
F3-19	Brake release delay	0.000–2.000	0.600	s	★
F3-20	Zero-speed control time at end	0.000–1.000	0.300	s	★
F3-21	Low-speed re-leveling speed	0.080 to F3-11	0.100	m/s	★
F3-22	Acceleration rate at emergency evacuation	0.100–1.300	0.100	m/s ²	★
F3-24	Program function selection	0: Reserved 1: Slip experiment enabled	0	-	★
Group F4: Floor parameters					
F4-00	Leveling adjustment	0–60	30	mm	★
F4-01	Current floor	F6-01 to F6-00	1	-	★
F4-02	High byte of current floor position	0–65535	1	Pulses	●
F4-03	Low byte of current floor position	0–65535	34464	Pulses	●

Function Code	Parameter Name	Setting Range	Default	Unit	Property
F4-04	Length 1 of leveling plate	0-65535	0	Pulses	★
F4-05	Length 2 of leveling plate	0-65535	0	Pulses	★
F4-06	High byte of floor height 1	0-65535	0	Pulses	★
F4-07	Low byte of floor height 1	0-65535	0	Pulses	★
F4-08	High byte of floor height 2	0-65535	0	Pulses	★
F4-09	Low byte of floor height 2	0-65535	0	Pulses	★
F4-10	High byte of floor height 3	0-65535	0	Pulses	★
F4-11	Low byte of floor height 3	0-65535	0	Pulses	★
F4-12	High byte of floor height 4	0-65535	0	Pulses	★
F4-13	Low byte of floor height 4	0-65535	0	Pulses	★
F4-14	High byte of floor height 5	0-65535	0	Pulses	★
F4-15	Low byte of floor height 5	0-65535	0	Pulses	★
F4-16	High byte of floor height 6	0-65535	0	Pulses	★
F4-17	Low byte of floor height 6	0-65535	0	Pulses	★
F4-18	High byte of floor height 7	0-65535	0	Pulses	★
F4-19	Low byte of floor height 7	0-65535	0	Pulses	★
F4-20	High byte of floor height 8	0-65535	0	Pulses	★
F4-21	Low byte of floor height 8	0-65535	0	Pulses	★
F4-22	High byte of floor height 9	0-65535	0	Pulses	★
F4-23	Low byte of floor height 9	0-65535	0	Pulses	★
F4-24	High byte of floor height 10	0-65535	0	Pulses	★

Function Code	Parameter Name	Setting Range	Default	Unit	Property
F4-25	Low byte of floor height 10	0-65535	0	Pulses	★
Floor height 11 to floor height 37					
F4-80	High byte of floor height 38	0-65535	0	Pulses	★
F4-81	Low byte of floor height 38	0-65535	0	Pulses	★
F4-82	High byte of floor height 39	0-65535	0	Pulses	★
F4-83	Low byte of floor height 39	0-65535	0	Pulses	★
Group F5: Terminal function parameters					
F5-00	Attendant/Automatic switchover time	3-200	3	s	★
F5-01	X1 function selection	08/40: Inspection signal 09/41: Inspection up signal	33	-	★
F5-02	X2 function selection	10/42: Inspection down signal 11/43: Fire emergency signal	35	-	★
F5-03	X3 function selection	12/44: Up limit signal 13/45: Down limit signal	34	-	★
F5-04	X4 function selection	14/46: Overload signal 15/47: Full-load signal 16/48: Up slow-down 1 signal	4	-	★
F5-05	X5 function selection	17/49: Down slow-down 1 signal	5	-	★
F5-06	X6 function selection	18/50: Up slow-down 2 signal 19/51: Down slow-down 2 signal	38	-	★
F5-07	X7 function selection	20/52: Up slow-down 3 signal 21/53: Down slow-down 3 signal	39	-	★
F5-08	X8 function selection	(To be continued)	22	-	★

Function Code	Parameter Name	Setting Range	Default	Unit	Property
F5-09	X9 function selection	22/54: Shorting door lock circuit contactor feedback	40	-	★
F5-10	X10 function selection	23/55: Firefighter switch signal	09	-	★
F5-11	X11 function selection	24/56: Door machine 1 light curtain signal	10	-	★
F5-12	X12 function selection	25/57: Door machine 2 light curtain signal 26/58: Brake travel switch 1	44	-	★
F5-13	X13 function selection	27/59: UPS valid signal 28/60: Elevator lock signal	45	-	★
F5-14	X14 function selection	29/61: Safety circuit 2	48	-	★
F5-15	X15 function selection	30/62: Shorting PMSM stator feedback signal 31/63: Door lock circuit 2 feedback signal	49	-	★
F5-16	X16 function selection	32/64: Reserved	50	-	★
F5-17	X17 function selection	65/97: Door machine 1 safety edge signal 66/98: Door machine 2 safety edge signal	51	-	★
F5-18	X18 function selection	67/99: Motor overheat signal	00	-	★
F5-19	X19 function selection	68/100: Earthquake signal 69/101: Back door forbidden signal	00	-	★
F5-20	X20 function selection	70/102: Light-load signal 71/103: Half-load signal	00	-	★
F5-21	X21 function selection	72/104: Fire emergency floor switchover signal	00	-	★
F5-22	X22 function selection	76/108: Door 1 open input 77/109: Door 2 open input	00	-	★
F5-23	X23 function selection	78/110: Brake travel switch 2 input	00	-	★
F5-24	X24 function selection	(End)	00	-	★
F5-25	CTB input type	0-511	320	-	★

Function Code	Parameter Name	Setting Range	Default	Unit	Property
F5-26	Y1 function selection	0: Invalid 1: RUN contactor control 2: Brake contactor control 3: Shorting door lock circuit contactor control	1	-	★
F5-27	Y2 function selection	4: Fire emergency floor arrival signal feedback 5: Door machine 1 open 6: Door machine 1 close 7: Door machine 2 open 8: Door machine 2 close	2	-	★
F5-28	Y3 function selection	9: Brake and RUN contactors healthy 10: Fault state 11: Running monitor	3	-	★
F5-29	Y4 function selection	12: Shorting PMSM stator contactor 13: Emergency evacuation automatic switchover 14: System healthy	4	-	★
F5-30	Y5 function selection	15: Emergency buzzer control 16: Higher-voltage startup of brake 17: Elevator running in up direction	0	-	★
F5-31	Y6 function selection	18: Lamp/Fan running 19: Medical sterilization 20: Non-door zone stop 21: Electric lock 22: Non-service state	0	-	★
F5-32	Communication state display	Monitoring of CANbus and Modbus communication states	-	-	●

Function Code	Parameter Name	Setting Range	Default	Unit	Property
F5-33	Terminal program control	Bit3: Elevator fire emergency requirement for Hong Kong Bit4: Arrival gong disabled at night Bit6: Door lock disconnected at inspection switched over to normal running Bit7: Fault code not displayed on the keypad Bit8: Door open command cancelled immediately at door open limit Bit9: Car stop and zero-speed torque holding at abnormal brake feedback	0	-	★
F5-34	Terminal state display	Monitoring of I/O terminals on MCB	-	-	●
F5-35	Terminal state display	Monitoring of I/O terminals on CTB, CCB and HOP	-	-	●
F5-36	Load cell input selection	0: Invalid 1: CTB digital input 2: CTB analog input 3: MCB analog input	1	-	★
F5-37	X25 function selection	0: No function	0	-	★
F5-38	X26 function selection	4: Safety circuit signal	0	-	★
F5-39	X27 function selection	5: Door lock circuit signal	0	-	★
Group F6: Basic elevator parameters					
F6-00	Top floor of the elevator	F6-01 to 40	9	-	★
F6-01	Bottom floor of the elevator	1 to F6-00	1	-	★
F6-02	Parking floor	F6-01 to F6-00	1	-	★
F6-03	Fire emergency floor	F6-01 to F6-00	1	-	★
F6-04	Elevator lock floor	F6-01 to F6-00	1	-	★
F6-05	Service floors 1	0-65535	65535	-	★
F6-06	Service floors 2	0-65535	65535	-	★

Function Code	Parameter Name	Setting Range	Default	Unit	Property
F6-07	Number of elevators in parallel/group mode	1-8	1	-	★
F6-08	Elevator No.	1-8	1	-	★
F6-09	Elevator program control	Bit0: Dispersed waiting Bit3: Parallel/Group control implemented at CAN2 Bit4: Group control in compatibility with NICE3000 Bit6: Clear floor number and display direction in advance Bit8: Unidirectional hall call (single hall call button) Bit 9: Not detecting analog wire breaking Bit10: Err30 judgment at re-leveling cancellation Bit14: Time interval detection of safety circuit 2 and door lock circuit 2	0	-	★
F6-10	Leveling sensor filter time	10-50	14	ms	★

Function Code	Parameter Name	Setting Range	Default	Unit	Property
F6-11	Elevator function selection	Bit1: Disabling returning to base floor for verification Bit2: Cancelling auto sequential arrange of hall call floor addresses to be displayed Bit5: Current detection valid at startup for synchronous motor Bit6: Reversing MCB lamp output Bit7: Door open valid at non-door zone in the inspection state Bit8: Door open and close once after inspection turned to normal Bit10: Buzzer not tweet upon re-leveling Bit11: Super short floor function Bit13: Err53 fault auto reset Bit14: Up slow-down not reset for super short floor Bit15: Down slow-down not reset for super short floor	8448	-	★
F6-12	VIP floor	0 to F6-00	0	-	★
F6-13	Security floor	0 to F6-00	0	-	★
F6-14	Start time of down collective selective 1	00.00–23.59	00.00	HH.MM	☆
F6-15	End time of down collective selective 1	00.00–23.59	00.00	HH.MM	☆
F6-16	Start time of down collective selective 2	00.00–23.59	00.00	HH.MM	☆
F6-17	End time of down collective selective 2	00.00–23.59	00.00	HH.MM	☆
F6-18	Start time of time-based floor service 1	00.00–23.59	00.00	HH.MM	☆
F6-19	End time of time-based floor service 1	00.00–23.59	00.00	HH.MM	☆

Function Code	Parameter Name	Setting Range	Default	Unit	Property
F6-20	Service floor 1 of time-based floor service 1	0-65535	65535	-	☆
F6-21	Service floor 2 of time-based floor service 1	0-65535	65535	-	☆
F6-22	Start time of time-based floor service 2	00.00-23.59	00.00	HH.MM	☆
F6-23	End time of time-based floor service 2	00.00-23.59	00.00	HH.MM	☆
F6-24	Service floor 1 of time-based floor service 2	0-65535	65535	-	☆
F6-25	Service floor 2 of time-based floor service 2	0-65535	65535	-	☆
F6-26	Peak 1 start time	00.00-23.59	00.00	HH.MM	☆
F6-27	Peak 1 end time	00.00-23.59	00.00	HH.MM	☆
F6-28	Peak 1 floor	F6-01 to F6-00	1	-	★
F6-29	Peak 2 start time	00.00-23.59	00.00	HH.MM	☆
F6-30	Peak 2 end time	00.00-23.59	00.00	HH.MM	☆
F6-31	Peak 2 floor	F6-01 to F6-00	1	-	★
F6-35	Service floor 3	0-65535	65535	-	☆
F6-36	Service floor 3 of time-based floor service 1	0-65535	65535	-	☆
F6-37	Service floor 3 of time-based floor service 2	0-65535	65535	-	☆
F6-38	Elevator lock start time	00.00-23.59	00.00	HH.MM	☆
F6-39	Elevator lock end time	00.00-23.59	00.00	HH.MM	☆

Function Code	Parameter Name	Setting Range	Default	Unit	Property
F6-40	Program control selection 1	Bit0: Disability function Bit1: Soft limit function Bit2: JP16 input used as back door selection Bit3: JP16 input used as the back door open signal Bit4: Opening only one door of opposite doors under manual control Bit5: Timed elevator lock Bit6: Manual door Bit7: Reserved Bit9: Disabling reverse floor number clear Bit10: Displaying next arriving floor number Bit11: Responding to car calls first Bit12: Car call assisted command in single door used as disability function Bit13: Folding command used as disability function and back door function Bit14: Car call command folding Bit15: JP20 used for switchover to back door	0	-	★

Function Code	Parameter Name	Setting Range	Default	Unit	Property
F6-41	Program control selection 2	Bit2: Inspection to stop due to slow-down 1 Bit4: Buzzer tweet during door open delay Bit6: Cancelling door open delay Bit8: Elevator lock at door open Bit9: Display available at elevator lock Bit10: Elevator lock in the attendant state Bit11: Blinking at arrival (within the time set in F6-47) Bit12: Door re-open during door open delay Bit13: Door re-open after car call of the present floor	0	-	★
F6-42	Program control selection 3	Bit1: Cancelling door open/close command at delay after door open/close limit Bit2: Not judging door lock state at door close output Bit3: Door close command output during running Bit4: Returning to base floor for verification at first-time power-on Bit5: Landing at nearest floor at elevator lock	0	-	★

Function Code	Parameter Name	Setting Range	Default	Unit	Property
F6-43	Attendant function selection	Bit0: Calls cancelled after entering attendant state Bit1: Not responding to hall calls Bit2: Attendant/ Automatic state switchover Bit3: Door close at jogging Bit4: Automatic door close Bit5: Buzzer tweeting at intervals in attendant state Bit6: Buzzer tweeting at intervals in attendant state Bit7: Car call button blinking to prompt	0	-	★

Function Code	Parameter Name	Setting Range	Default	Unit	Property
F6-44	Fire emergency function selection	Bit3: Arrival gong output in inspection or fire emergency state Bit4: Multiple car calls registered in fire emergency state Bit5: Retentive at power failure in fire emergency state Bit6: Closing door by holding down the door close button Bit7: Reserved Bit8: Door close at car call registering Bit9: Displaying hall calls in fire emergency state Bit10: Firefighter forced running Bit11: Exiting fire emergency state for firefighter Bit12: Not clearing car calls at reverse door open in firefighter running state Bit14: Opening door by holding down the door open button Bit15: Automatic door open in fire emergency floor	16456	-	★

Function Code	Parameter Name	Setting Range	Default	Unit	Property
F6-45	Emergency evacuation function selection	Bit0-Bit1: Direction determine mode (00: Automatically calculating direction; 01: Load direction determining; 10: Direction of nearest landing floor) Bit2: Stopping at evacuation parking floor Bit3: Reserved Bit4: Compensation at startup Bit8: Emergency running time protection Bit10: Emergency buzzer output Bit12: Shorting stator braking mode switched over to controller drive Bit13: Mode of shorting stator braking mode switched over to controller drive Bit14: Emergency evacuation exit mode Bit15: Function selection of shorting stator braking mode	0	-	★
F6-46	VIP function selection	Bit0: VIP enabled by hall call (at VIP floor) Bit1: VIP enabled by terminal Bit8: Number of VIP car calls limited	0	s	★
F6-47	Blinking advance time	0.0–15.0	0	s	☆
F6-48	Emergency evacuation switching speed	0.010–0.630	0.010	m/s	★
F6-49	Evacuation parking floor	0 to F6-01	0	-	★
Group F7: Test function parameters					
F7-00	Car call floor registered	0 to F6-00	0	-	☆
F7-01	Up call floor registered	0 to F6-00	0	-	☆

Function Code	Parameter Name	Setting Range	Default	Unit	Property
F7-02	Down call floor registered	0 to F6-00	0	-	☆
F7-03	Random running times	0–60000	0	-	☆
F7-04	Hall call enabled	0: Yes 1: No	0	-	☆
F7-05	Door open enabled	0: Yes 1: No	0	-	☆
F7-06	Overload function	0: Disabled 1: Enabled	0	-	☆
F7-07	Limit switch	0: Enabled 1: Disabled	0	-	☆
F7-08	Time interval of random running	0–1000	0	s	☆
Group F8: Enhanced function parameters					
F8-00	Load for load cell auto-tuning	0–100	0	%	★
F8-01	Pre-torque selection	0: Pre-torque invalid 1: Load cell pre-torque compensation 2: Automatic pre-torque compensation	0	-	★
F8-02	Pre-torque offset	0.0–100.0	50.0	%	★
F8-03	Drive gain	0.00–2.00	0.60	-	★
F8-04	Brake gain	0.00–2.00	0.60	-	★
F8-05	Current car load	0–1023	0	-	●
F8-06	Car no-load load	0–1023	0	-	★
F8-07	Car full-load load	0–1023	100	-	★
F8-08	Anti-nuisance function	0: Anti-nuisance function disabled 1: Nuisance judged by load cell 2: Nuisance judged by light curtain 4: Nuisance judged by light-load signal	0	-	☆
F8-09	Emergency evacuation operation speed at power failure	0.000 to F3-11	0.050	m/s	★

Function Code	Parameter Name	Setting Range	Default	Unit	Property
F8-10	Emergency evacuation operation mode at power failure	0: Motor not running 1: UPS 2: 48 V battery power supply	0	-	★
F8-11	Brake apply delay	0.200–1.500	0.200	s	☆
F8-12	Fire emergency floor 2	0 to F6-00	0	-	☆
F8-14	HCB communication setting	Bit4: Energy saving of HCB communication	0	-	☆
F8-16	Start address of hall call auxiliary command	0–40	0	-	☆
F8-17	Hall call address check	0–1	0	-	☆
Group F9: Time parameters					
F9-00	Idle time before returning to base floor	0–240	10	min	☆
F9-01	Time for fan and lamp to be turned off	0–240	2	min	☆
F9-02	Motor running time limit	0–45	45	s	★
F9-03	Clock: year	2000–2100	Current year	YYYY	☆
F9-04	Clock: month	1–12	Current month	MM	☆
F9-05	Clock: day	1–31	Current day	DD	☆
F9-06	Clock: hour	0–23	Current hour	HH	☆
F9-07	Clock: minute	0–59	Current minute	MM	☆
F9-09	Accumulative running time	0–65535	0	h	●
F9-11	High byte of running times	0–9999	0	-	●
F9-12	Low byte of running times	0–9999	0	-	●
F9-13	Maintenance notification period	0–99	0	day	★

Function Code	Parameter Name	Setting Range	Default	Unit	Property
Group FA: Keypad setting parameters					
FA-00	Keypad display selection	0: Reversed display of physical floor 1: Positive display of physical floor 2: Reversed display of hall call floor 3: Positive display of hall call floor	3	-	☆
FA-01	Display in running state	1-65535	65535	-	☆
FA-02	Display in stop state	1-65535	65535	-	☆
FA-03	Current encoder angle	0.0-359.9	0.0	Degree (°)	●
FA-05	Control board software (ZK)	0-65535	0	-	●
FA-06	Drive board software (DSP)	0-65535	0	-	●
FA-07	Heatsink temperature	0-100	0	°C	●
FA-11	Pre-torque current	0.0-200.0	0	%	●
FA-12	Logic information	0-65535	0	-	●
FA-13	Curve information	0-65535	0	-	●
FA-14	Set speed	0.000-4.000	0	m/s	●
FA-15	Feedback speed	0.000-4.000	0	m/s	●
FA-16	Bus voltage	0-999.9	0	V	●
FA-17	Present position	0.00-300.0	0	m	●
FA-18	Output current	0.0-999.9	0	A	●
FA-19	Output frequency	0.00-99.99	0	Hz	●
FA-20	Torque current	0.0-999.9	0	A	●
FA-21	Output voltage	0-999.9	0	V	●
FA-22	Output torque	0-100	0	%	●
FA-23	Output power	0.00-99.99	0	kW	●
FA-24	Communication interference	0-65535	0	-	●
FA-26	Input state 1	0-65535	0	-	●

Function Code	Parameter Name	Setting Range	Default	Unit	Property
FA-27	Input state 2	0-65535	0	-	●
FA-28	Input state 3	0-65535	0	-	●
FA-30	Input state 5	0-65535	0	-	●
FA-31	Output state 1	0-65535	0	-	●
FA-32	Output state 2	0-65535	0	-	●
FA-33	Car input state	0-65535	0	-	●
FA-34	Car output state	0-65535	0	-	●
FA-35	Hall state	0-65535	0	-	●
FA-36	System state 1	0-65535	0	-	●
FA-37	System state 2	0-65535	0	-	●
FA-46	Hall call communication state 1	0-65535 (floors 1-16)	0	-	●
FA-47	Hall call communication state 2	0-65535 (floors 17-32)	0	-	●
FA-48	Hall call communication state 3	0-65535 (floors 33-40)	0	-	●
Group Fb: Door function parameters					
Fb-00	Number of door machine(s)	1-2	1	-	☆
Fb-01	CTB software	00-999	0	-	●
Fb-02	Service floors 1 of door machine 1	0-65535	65535	-	☆
Fb-03	Service floors 2 of door machine 1	0-65535	65535	-	☆
Fb-04	Service floors 1 of door machine 2	0-65535	65535	-	☆
Fb-05	Service floors 2 of door machine 2	0-65535	65535	-	☆
Fb-06	Door open protection time	5-99	10	s	☆
Fb-07	Arrival gong output delay	0-1000	0	ms	☆
Fb-08	Door close protection time	5-99	15	s	☆
Fb-09	Door re-open times	0-20	0	-	☆

Function Code	Parameter Name	Setting Range	Default	Unit	Property
Fb-10	Door state of standby elevator	0: Closing the door as normal at base floor 1: Waiting with door open at base floor 2: Waiting with door open at each floor	0	-	☆
Fb-11	Door open holding time for hall call	1-1000	5	s	☆
Fb-12	Door open holding time for car call	1-1000	3	s	☆
Fb-13	Door open holding time at base floor	1-1000	10	s	☆
Fb-14	Door open delay	10-1000	30	s	☆
Fb-15	Special door open holding time	10-1000	30	s	☆
Fb-16	Manual door open holding time	1-60	5	s	☆
Fb-17	Holding time for forced door close	5-180	120	s	☆
Fb-18	Service floors 3 of door machine 1	0-65535	65535	-	☆
Fb-19	Service floors 3 of door machine 2	0-65535	65535	-	☆
Group FC: Protection function parameters					
FC-00	Program control for protection function	Bit0: Short-circuit to ground detection at power-on Bit2: Decelerating to stop at valid light curtain Bit9: Mode without door open/close limit	0	-	★

Function Code	Parameter Name	Setting Range	Default	Unit	Property
FC-01	Program control 2 for protection function	Bit0: Overload protection Bit1: Canceling protection at output phase loss Bit2: Canceling over-modulation function Bit4: Light curtain judgment at door close limit Bit5: Canceling SPI communication judgment Bit14: Canceling protection at input phase loss	65	-	★
FC-02	Overload protection coefficient	0.50–10.00	1.00	-	★
FC-03	Overload pre-warning coefficient	50%–100%	80%	-	★
FC-04	Opposite door selection	0–3	0	-	★
FC-06	Designated fault	0–99	0	-	☆
FC-07	Designated fault code	0–9999	0	-	●
FC-08	Designated fault subcode	0–65535	0	-	●
FC-09	Designated fault month and day	0–1231	0	MM.DD	●
FC-10	Designated fault hour and minute	0–23.59	0	HH.MM	●
FC-11	Logic information of designated fault	0–65535	0	-	●
FC-12	Curve information of designated fault	0–65535	0	-	●
FC-13	Set speed upon designated fault	0.000–4.000	0	m/s	●
FC-14	Feedback speed upon designated fault	0.000–4.000	0	m/s	●
FC-15	Bus voltage upon designated fault	0.0–999.9	0	v	●
FC-16	Current position upon designated fault	0.0–300.0	0	m	●
FC-17	Output current upon designated fault	0.0–999.9	0	A	●

Function Code	Parameter Name	Setting Range	Default	Unit	Property
FC-18	Output frequency upon designated fault	0.00–99.99	0	Hz	●
FC-19	Torque current upon designated fault	0.0–999.9	0	A	●
FC-20	1st fault code	0–9999	0	-	●
FC-21	1st fault subcode	0–65535	0	-	●
FC-22	1st fault month and day	0–1231	0	MM.DD	●
FC-23	1st fault hour and minute	0–23.59	0	HH.MM	●
FC-24	2nd fault code	0–9999	0	-	●
FC-25	2nd fault subcode	0–65535	0	-	●
FC-26	2nd fault month and day	0–1231	0	MM.DD	●
FC-27	2nd fault hour and minute	0–23.59	0	HH.MM	●
FC-28	3rd fault code	0–9999	0	-	●
FC-29	3rd fault subcode	0–65535	0	-	●
FC-30	3rd fault month and day	0–1231	0	MM.DD	●
FC-31	3rd fault hour and minute	0–23.59	0	HH.MM	●
FC-32	4th fault code	0–9999	0	-	●
FC-33	4th fault subcode	0–65535	0	-	●
FC-34	4th fault month and day	0–1231	0	MM.DD	●
FC-35	4th fault hour and minute	0–23.59	0	HH.MM	●
...					
FC-56	10th fault code	0–9999	0	-	●
FC-57	10th fault subcode	0–65535	0	-	●
FC-58	10th fault month and day	0–1231	0	MM.DD	●
FC-59	10th fault hour and minute	0–23.59	0	HH.MM	●
FC-60	Latest fault code	0–9999	0	-	●
FC-61	Latest fault subcode	0–65535	0	-	●
FC-62	Latest fault month and day	0–1231	0	MM.DD	●

Function Code	Parameter Name	Setting Range	Default	Unit	Property
FC-63	Latest fault hour and minute	0–23.59	0	HH.MM	●
FC-64	Logic information of latest fault	0–65535	0	-	●
FC-65	Curve information of latest fault	0–65535	0	-	●
FC-66	Set speed upon latest fault	0.000–4.000	0	m/s	●
FC-67	Feedback speed upon latest fault	0.000–4.000	0	m/s	●
FC-68	Bus voltage upon latest fault	0.0–999.9	0	v	●
FC-69	Current position upon latest fault	0.0–300.0	0	m	●
FC-70	Output current upon latest fault	0–999.9	0	A	●
FC-71	Output frequency upon latest fault	0.00–99.99	0	Hz	●
FC-72	Torque current upon latest fault	0.0–999.9	0	A	●
Group Fd: Communication parameters					
Fd-00	Baud rate	0: 9600 1: 38400	0	bit/s	★
Fd-02	Local address	0–127 0: Broadcast address	1	-	★
Fd-03	Communication response delay	0–20	10	ms	★
Fd-04	Communication timeout	0.0–60.0	0.0	s	★
Fd-05	Re-leveling stop delay	0.00–2.00	0.00	s	★

Function Code	Parameter Name	Setting Range	Default	Unit	Property
Fd-07	HCB:JP1 input	0: Reserved NO/NC input: 1/33: Elevator lock signal 2/34: Fire emergency signal	1	-	★
Fd-08	HCB:JP2 input	3/35: Current floor forbidden 4/36: VIP floor signal 5/37: Security floor signal 6/38: Door close button input signal 7/39: Second fire emergency floor signal	2	-	★
Fd-09	HCB:JP1 output	0: Invalid 1: Up arrival indicator 2: Down arrival indicator 3: Fault output 4: Non-door zone stop output	1	-	★
Fd-10	HCB:JP2 output	5: Non-service state output 6: Door close button indicator output	2	-	★
Fd-11	HCB-B:JP1 input	0: Reserved NO/NC input:	0	-	★
Fd-12	HCB-B:JP2 input	1/33: Light-load signal	0	-	★
Fd-13	HCB-B:JP3 input	2/34: Half-load signal 3/35: Door 2 selection	0	-	★
Fd-14	HCB-B:JP4 input	4/36: Door 2 restricted (back door forbidden)	0	-	★
Fd-15	HCB-B:JP5 input	5/37: Door 1 safety edge 6/38: Door 2 safety edge	0	-	★
Fd-16	HCB-B:JP6 input	7/39: Single/Double door selection	0	-	★

Function Code	Parameter Name	Setting Range	Default	Unit	Property
Fd-17	HCB-B:A1 output	0: Reserved	0	-	★
Fd-18	HCB-B:A2 output	1: Fault output	0	-	★
Fd-19	HCB-B:B1 output	2: Non-door zone stop output	0	-	★
Fd-20	HCB-B:B2 output		0	-	★
Fd-21	HCB-B:C1 output	3: Non-service state output	0	-	★
Fd-22	HCB-B:C2 output	4: Fire emergency output	0	-	★
Fd-23	HCB-B:C3 output	5: Power failure emergency output	0	-	★
Fd-24	HCB-B:C4 output		0	-	★
Fd-25	HCB-B:C5 output	6: Door lock valid	0	-	★
Fd-26	HCB-B:C6 output	7: Night output signal	0	-	★
Group FE: Elevator function parameters					
FE-00	Collective selective mode	0: Full collective selective 1: Down collective selective 2: Up collective selective	0	-	★
FE-01	Floor 1 display	The two high digits indicate the display code of the ten's digit, and the two low digits indicate the display code of the unit's digit.	1901	-	☆
FE-02	Floor 2 display	00: Display "0" 01: Display "1" 02: Display "2"	1902	-	☆
FE-03	Floor 3 display	03: Display "3" 04: Display "4" 05: Display "5"	1903	-	☆
FE-04	Floor 4 display	06: Display "6" 07: Display "7" 08: Display "8" 09: Display "9"	1904	-	☆
FE-05	Floor 5 display	10: Display "A" 11: Display "B" 12: Display "G" 13: Display "H"	1905	-	☆
FE-06	Floor 6 display	14: Display "L" 15: Display "M" 16: Display "P" (To be continued)	1906	-	☆

Function Code	Parameter Name	Setting Range	Default	Unit	Property
FE-07	Floor 7 display	17: Display "R"	1907	-	☆
FE-08	Floor 8 display	18: Display "-"	1908	-	☆
FE-09	Floor 9 display	19: No display	1909	-	☆
FE-10	Floor 10 display	20: Display "12"	0100	-	☆
FE-11	Floor 11 display	21: Display "13"	0101	-	☆
FE-12	Floor 12 display	22: Display "23"	0102	-	☆
FE-13	Floor 13 display	23: Display "C"	0103	-	☆
FE-14	Floor 14 display	24: Display "D"	0104	-	☆
FE-15	Floor 15 display	25: Display "E"	0105	-	☆
Floor 16 to floor 30 display		26: Display "F"			
		27: Display "I"			
FE-31	Floor 31 display	28: Display "J"	0301	-	☆
FE-35	Floor 32 display	29: Display "K"	0302	-	☆
FE-36	Floor 33 display	30: Display "N"	0303	-	☆
FE-37	Floor 34 display	31: Display "O"	0304	-	☆
FE-38	Floor 35 display	32: Display "Q"	0305	-	☆
FE-39	Floor 36 display	33: Display "S"	0306	-	☆
FE-40	Floor 37 display	34: Display "T"	0307	-	☆
FE-41	Floor 38 display	35: Display "U"	0308	-	☆
FE-42	Floor 39 display	36: Display "V"	0309	-	☆
FE-43	Floor 40 display	37: Display "W"	0400	-	☆
FE-52	Highest digit selection 1	38: Display "X"	0	-	☆
FE-53	Highest digit selection 2	39: Display "Y"	0	-	☆
FE-54	Highest digit selection 3	40: Display "Z"	0	-	☆
FE-55	Highest digit selection 4	41: Display "15"	0	-	☆
FE-56	Highest digit selection 5	42: Display "17"	0	-	☆
		43: Display "19"	0	-	☆
		(End)	0	-	☆

Function Code	Parameter Name	Setting Range	Default	Unit	Property
FE-32	Elevator function selection 1	Bit2: Re-leveling function Bit3: Door pre-open function Bit4: Stuck hall call cancellation Bit5: Night security floor function Bit6: Down collective selective peak service Bit7: Parallel/Group control peak service Bit8: Time-based service floor function Bit9: VIP function Bit11: Car call deletion Bit12: Hall call deletion Bit15: Reserved	34816	-	☆
FE-33	Elevator function selection 2	Bit1: Door open holding at open limit Bit2: Door close command not output upon door close limit Bit4: Auto reset for RUN and brake contactor stuck Bit5: Slow-down switch stuck detection Bit7: Forced door close Bit8: NO/NC output selection of shorting motor stator contactor Bit9: Immediate stop upon re-leveling Bit13: High-speed elevator protection function Bit15: Opposite door independent control	36	-	☆

Function Code	Parameter Name	Setting Range	Default	Unit	Property	
Group Fr: Leveling adjustment parameters						
Fr-00	Leveling adjustment function	0: Disabled 1: Enabled	0	-	★	
Fr-01	Leveling adjustment record 1	00000–60060	30030	mm	★	
Fr-02	Leveling adjustment record 2		30030	mm	★	
...			...			
Fr-20	Leveling adjustment record 20		30030	mm	★	
Group FF: Factory parameters						
Group FP: User parameters						
FP-00	User password	0–65535	0	-	☆	
FP-01	Parameter update	0: No operation 1: Restore default settings 2: Clear fault records	0	-	★	
FP-02	User-defined parameter display	0: Invalid 1: Valid	0	-	★	



Description of Function Codes

Chapter 7 Description of Function Codes

Group F0: Basic Parameters

Function Code	Parameter Name	Setting Range	Default	Unit	Property
F0-00	Control mode	<ul style="list-style-type: none"> • 0: Sensorless vector control (SVC) • 1: Closed-loop vector control (CLVC) • 2: Voltage/Frequency (V/F) control 	1	-	★

It is used to set the control mode of the system.

- 0: Sensorless vector control (SVC)

It is applicable to low-speed running during no-load commissioning of the asynchronous motor, fault judgment at inspection, and synchronous motor running on special conditions.

- 1: Closed-loop vector control (CLVC)

It is applicable to normal running in distance control.



- 2: Voltage/Frequency (V/F) control

It is applicable to equipment detection where the ratio between the voltage and the frequency is fixed, control is simple, and the low-frequency output torque feature is poor.

Function Code	Parameter Name	Setting Range	Default	Unit	Property
F0-01	Command source selection	0: Operation panel control 1: Distance control	1	-	★

It is used to set the source of running commands and running speed references.

- 0: Operation panel control

The controller is operated by pressing  and  on the operation panel, and the running speed is set by F0-02 (Running speed under operation panel control). This method is applicable only to the test or motor no-load auto-tuning.

- 1: Distance control

This method is used in the NICE series integrated elevator controller. During inspection, the elevator runs at the speed set in F3-11. During normal running, the controller automatically calculates the speed and running curve for the elevator based on the distance between the current floor and the target floor within the rated elevator speed, implementing direct travel ride.

Function Code	Parameter Name	Setting Range	Default	Unit	Property
F0-02	Running speed under operation panel control	0.050 to F0-04	0.050	m/s	☆

It is used to set the running speed in the operation panel control mode.

Note that this function is enabled only when F0-01 is set to 0 (Operation panel control). You can change the running speed of the elevator by modifying this parameter during running

Function Code	Parameter Name	Setting Range	Default	Unit	Property
F0-03	Maximum running speed	0.250 to F0-04	1.600	m/s	★

It is used to set the actual maximum running speed of the elevator. The value must be smaller than the rated elevator speed.

Function Code	Parameter Name	Setting Range	Default	Unit	Property
F0-04	Rated elevator speed	0.250–4.000	1.600	m/s	★

It is used to set the nominal rated speed of the elevator. The value of this parameter is dependent on the elevator mechanism and traction motor.

Note

F0-03 is the actual running speed within the elevator speed range set in F0-04. For example, for a certain elevator, if F0-04 is 1.750 m/s and the actually required maximum running speed is 1.600 m/s, set F0-03 to 1.600 m/s.

Function Code	Parameter Name	Setting Range	Default	Unit	Property
F0-05	Rated elevator load	300–9999	1000	kg	★

It is used to set the rated elevator load. This parameter is used for the anti- nuisance function.

Function Code	Parameter Name	Setting Range	Default	Unit	Property
F0-06	Maximum frequency	20.00–99.00	50.00	Hz	★

It is used to set the maximum output frequency of the system. This value must be larger than the rated motor frequency.

Function Code	Parameter Name	Setting Range	Default	Unit	Property
F0-07	Carrier frequency	0.5–16.0	6.0	kHz	★

It is used to set the carrier frequency of the controller.

The carrier frequency is closely related to the motor noise during running. When it is generally set above 6 kHz, mute running is achieved. It is recommended to set the carrier frequency to the lowest within the allowable noise, which reduces the controller loss and radio frequency interference.

- If the carrier frequency is low, output current has high harmonics, and the power loss and temperature rise of the motor increase.

- If the carrier frequency is high, power loss and temperature rise of the motor declines. However, the system has an increase in power loss, temperature rise and interference.

Adjusting the carrier frequency will exert influences on the aspects listed in the following table.

Table 7-1 Influences of carrier frequency adjustment

Carrier frequency	Low	High
Motor noise	Large	Small
Output current waveform	Bad	Good
Motor temperature rise	High	Low
Controller temperature rise	Low	High
Leakage current	Small	Large
External radiation interference	Small	Large

Note

On certain environment conditions (the heatsink temperature is too high), the system will reduce the carrier frequency to provide overheat protection for the controller, preventing the controller from being damaged due to overheat. If the temperature cannot reduce in this case, the controller reports the overheat fault.

Group F1: Motor Parameter

Function Code	Parameter Name	Setting Range	Default	Unit	Property
F1-00	Encoder type	0: SIN/COS encoder, absolute encoder 1: UVW encoder 2: ABZ incremental encoder	0	-	★

It is used to set the encoder type matching the motor.

When F1-25 is set to 1 (Synchronous motor), set this parameter correctly before auto-tuning; otherwise, the motor cannot run properly.

When F1-25 is set to 0 (Asynchronous motor), this parameter is automatically changed to 2. You need not modify it manually.

Function Code	Parameter Name	Setting Range	Default	Unit	Property
F1-01	Rated motor power	0.7–75.0	Model dependent	kW	★
F1-02	Rated motor voltage	0–600	Model dependent	V	★
F1-03	Rated motor current	0.00–655.00	Model dependent	A	★

Function Code	Parameter Name	Setting Range	Default	Unit	Property
F1-04	Rated motor frequency	0.00–99.00	Model dependent	Hz	★
F1-05	Rated motor rotational speed	0–3000	Model dependent	RPM	★

Set these parameters according to the motor nameplate.

Ensure that these motor parameters are set correctly. Incorrect setting affects the motor auto-tuning and the vector control effect.

Function Code	Parameter Name	Setting Range	Default	Unit	Property
F1-06	Encoder initial angle (synchronous motor)	0.0–359.9	0	Degree (°)	★
F1-07	Encoder angle at power-off (synchronous motor)	0.0–359.9	0	Degree (°)	★
F1-08	Synchronous motor wiring mode	0–15	0	-	★

These parameters are obtained by means of motor auto-tuning.

F1-06 specifies the encoder angle at zero point. After multiple times of auto-tuning, compare the obtained values, and the value deviation of F1-06 shall be within $\pm 5^\circ$.

F1-07 specifies the angle of the magnetic pole when the motor is powered off. The value is recorded at power-off and is used for comparison at next power-on.

F1-08 specifies the motor wiring mode, that is, whether the output phase sequence of the drive board is consistent with the UVW phase sequence of the motor. If the value obtained by means of no-load auto-tuning is an even number, the phase sequence is correct. If the value is an odd number, the sequence is incorrect; in this case, exchange any two of UWW phases of the motor.

Note

With-load auto-tuning of the synchronous motor can be performed only when the UVW phase sequence of the motor is consistent with the output phase sequence of the controller.

Function Code	Parameter Name	Setting Range	Default	Unit	Property
F1-09	Current filter time (synchronous motor)	0–3	0	-	★

It is used to set the current filter time, which suppress the periodic vertical jitter. Increase the value in ascending order of 0.5 to achieve the optimum effect.

Function Code	Parameter Name	Setting Range	Default	Unit	Property
F1-10	Encoder verification selection	0–65535	0	-	★

It is used to set encoder signal verification. This parameter is set by the manufacturer, and you need not modify it generally.

Function Code	Parameter Name	Setting Range	Default	Unit	Property
F1-11	Auto-tuning mode	0: No operation 1: With-load auto-tuning 2: No-load auto-tuning 3: Shaft auto-tuning	0	-	★

It is used to select the auto-tuning mode.

"With-load auto-tuning" is static auto-tuning for the asynchronous motor and rotary auto-tuning for the synchronous motor. "No-load auto-tuning" is complete auto-tuning, by which all motor parameters can be obtained.

When F1-11 is set to 2 (No-load auto-tuning), the motor must be completely disconnected from the load; otherwise, the auto-tuning effect will be affected. When TUNE is displayed on the operation panel, you need to manually release the brake before starting auto-tuning. For details on the auto-tuning process, see the description in section 5.1.

Function Code	Parameter Name	Setting Range	Default	Unit	Property
F1-12	Encoder pulses per revolution	0–10000	2048	PPR	★

It is used to set the pulses per revolution of the encoder (according to the encoder nameplate).

This parameter is critical to CLVC. Set the encoder nominal value in this parameter. Otherwise, the elevator may not run properly. When the feedback pulses received by the system is data after frequency division by other equipment, set the frequency-division value rather than the encoder nominal value in this parameter. For example, if the pulses per revolution of the encoder is 8192 and is sent to the system after 1/4 frequency division, set this parameter to 2048 ($8192/4 = 2048$).

F0-04 (Rated elevator speed), F1-05 (Rated motor rotational speed), and F1-12 (Encoder pulses per revolution) determine whether the elevator can run properly. If any of these parameters is changed, shaft auto-tuning must be performed again.

Function Code	Parameter Name	Setting Range	Default	Unit	Property
F1-13	Encoder wire-breaking detection time	0–10.0	1.0	s	★

This parameter is used to set the time that a wire-break fault lasts before being detected.

After the elevator starts running at non-zero speed, if there is no encoder signal input within the time set in this parameter, the system prompts the encoder fault and stops running.

When the value is smaller than 0.5s, this function is disabled.

Function Code	Parameter Name	Setting Range	Default	Unit	Property
F1-14	Stator resistance (asynchronous motor)	0.000–30.000	Model dependent	Ω	★
F1-15	Rotor resistance (asynchronous motor)	0.000–30.000	Model dependent	Ω	★
F1-16	Leakage inductance (asynchronous motor)	0.00–300.00	Model dependent	mH	★

Function Code	Parameter Name	Setting Range	Default	Unit	Property
F1-17	Mutual inductance (asynchronous motor)	0.1–3000.0	Model dependent	mH	★
F1-18	Magnetizing current (asynchronous motor)	0.01–300.00	Model dependent	A	★

These parameters are obtained by means of motor auto-tuning. After the motor auto-tuning is completed successfully, the values of these parameters are updated automatically.

If motor auto-tuning cannot be performed onsite, manually enter the values by referring to data of the motor with the same nameplate parameters.

Each time F1-01 (Rated motor power) of the asynchronous motor is modified, these parameters automatically resume to the default values for the standard motor.

Function Code	Parameter Name	Setting Range	Default	Unit	Property
F1-19	Shaft Q inductance (torque)	0.00–650.00	3.00	mH	★
F1-20	Shaft D inductance (excitation)	0.00–650.00	3.00	mH	★
F1-21	Back EMF	0–65535	0	-	★

These parameters are obtained by means of motor auto-tuning.

Function Code	Parameter Name	Setting Range	Default	Unit	Property
F1-25	Motor type	0: Asynchronous motor 1: Synchronous motor	1	-	★

It is used to set the motor type. This parameter must be set correctly before motor auto-tuning; otherwise, the motor auto-tuning cannot be performed.

Group F2: Vector Control Parameters

Function Code	Parameter Name	Setting Range	Default	Unit	Property
F2-00	Speed loop proportional gain KP1	0–100	40	-	★
F2-01	Speed loop integral time TI1	0.01–10.00	0.60	s	★
F2-02	Switchover frequency 1	0.00 to F2-05	2.00	Hz	★

F2-00 and F2-01 are PI regulation parameters when the running frequency is smaller than the value of F2-02 (Switchover frequency 1).

Function Code	Parameter Name	Setting Range	Default	Unit	Property
F2-03	Speed loop proportional gain KP2	0–100	35	-	★
F2-04	Speed loop integral time TI2	0.01–10.00	0.80	s	★
F2-05	Switchover frequency 2	F2-02 to F0-06	5.00	Hz	★

F2-03 and F2-04 are PI regulation parameters when the running frequency is larger than the value of F2-05 (Switchover frequency 2).

If the running frequency is between F2-02 and F2-05, the speed loop PI parameters are obtained from the weighted average value of the two groups of PI parameters (F2-00, F2-01 and F2-03, F2-04), as shown in Figure 7-1.

Figure 7-1 Relationship between running frequencies and PI parameters

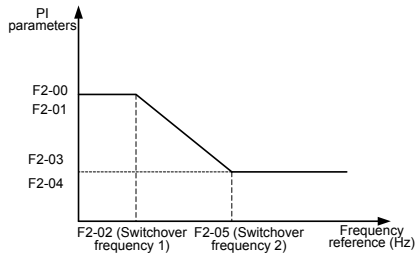

The speed dynamic response characteristics in vector control can be adjusted by setting the proportional gain and integral time of the speed regulator.

To achieve a faster system response, increase the proportional gain and reduce the integral time. Be aware that this may lead to system oscillation.

The recommended adjustment method is as follows:

If the default setting cannot meet the requirements, make proper adjustment. Increase the proportional gain first to ensure that the system does not oscillate, and then reduce the integral time to ensure that the system has quick response and small overshoot.

If both F2-02 (Switchover frequency 1) and F2-05 (Switchover frequency 2) are 0, only F2-03 and F2-04 are valid.

Function Code	Parameter Name	Setting Range	Default	Unit	Property
F2-06	Current loop KP1 (torque)	10–500	60	-	★
F2-07	Current loop K11 (torque)	10–500	30	-	★

These two parameters are regulation parameters for the torque axis current loop.

These parameters are used as the torque axis current regulator in vector control. The best values of the parameters matching the motor characteristics are obtained by means of motor auto-tuning. You need not modify them generally.

Function Code	Parameter Name	Setting Range	Default	Unit	Property
F2-08	Torque upper limit	0.0–200.0	150.0	%	★

It is used to set the torque upper limit of the motor. The value 100% corresponds to the rated output torque of the adaptable motor.

Function Code	Parameter Name	Setting Range	Default	Unit	Property
F2-10	Elevator running direction	0–1	0	-	★

It is used to set the elevator running direction.

The values are as follows:

- 0: Direction unchanged
- 1: Direction reversed

You can modify this parameter to reverse the running direction (without changing the wiring of the motor).

When you perform inspection running for the first time after motor auto-tuning is successful, check whether the actual motor running direction is consistent with the inspection command direction. If not, change the motor running direction by setting F2-10 to consistent with the inspection command direction.

Pay attention to the setting of this parameter when restoring the default setting.

Function Code	Parameter Name	Setting Range	Default	Unit	Property
F2-11	Zero servo current coefficient	0.20–50.0	15	-	★
F2-12	Zero servo speed loop KP	0.00–2.00	0.5	-	★
F2-13	Zero servo speed loop KI	0.00–2.00	0.6	-	★

These parameters are used to adjust automatic pre-torque compensation in the case of no-load-cell. The no-load-cell startup function is enabled when F8-01 is set to 2.

Decrease the values of these parameters in the case of car lurch at startup, and increase the values in the case of rollback at startup. For details, see the description of section 5.1.5.

Function Code	Parameter Name	Setting Range	Default	Unit	Property
F2-16	Torque acceleration time	1–500	1	ms	★
F2-17	Torque deceleration time	1–500	350	ms	★

These two parameters are used to set the acceleration time and deceleration time of the torque current.

Due to different characteristics, the motor may have an abnormal sound when the current is withdrawn at stop. In this case, you can increase the torque deceleration time properly to eliminate the abnormal sound.

Function Code	Parameter Name	Setting Range	Default	Unit	Property
F2-18	Startup acceleration time	0.000–1.500	0.000	s	★

It is used to set the acceleration time of the startup speed. It is used with F3-00. For details, see Figure 7-2.

Group F3: Running Control Parameters

Function Code	Parameter Name	Setting Range	Default	Unit	Property
F3-00	Startup speed	0.000–0.030	0.000	m/s	★
F3-01	Startup holding time	0.000–0.500	0.000	s	★

These two parameters are used to set the startup speed and startup speed holding time. For details, see Figure 7-2.

The parameters may reduce the terrace feeling at startup due to static friction between the guide rail and the guide shoes.

Function Code	Parameter Name	Setting Range	Default	Unit	Property
F3-02	Acceleration rate	0.200–1.500	0.600	m/s ²	★
F3-03	Acceleration start jerk time	0.300–4.000	2.500	s	★
F3-04	Acceleration end jerk time	0.300–4.000	2.500	s	★

These parameters are used to set the running curve during acceleration of the elevator.

Function Code	Parameter Name	Setting Range	Default	Unit	Property
F3-05	Deceleration rate	0.200–1.500	0.600	m/s ²	★
F3-06	Deceleration end jerk time	0.300–4.000	2.500	s	★
F3-07	Deceleration start jerk time	0.300–4.000	2.500	s	★

These parameters are used to set the running curve during deceleration of the elevator.

- F3-02 (F3-05) is the acceleration rate (deceleration rate) in the straight-line acceleration process (deceleration process) of the S curve.
- F3-03 (F3-07) is the time for the rate to increase from 0 to the value set in F3-02 (F3-05) in the end jerk segment of the S curve. The larger the value is, the smoother the jerk is.
- F3-04 (F3-06) is the time for the rate to decrease from the value set in F3-02 (F3-05) to 0 in the start jerk segment of the S curve. The larger the value is, the smoother the jerk is.

Figure 7-2 Setting the running curve

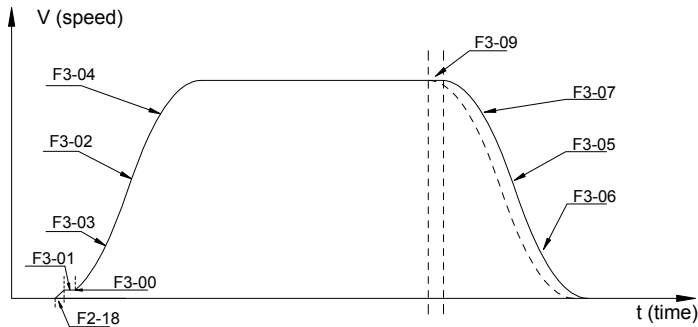

Function Code	Parameter Name	Setting Range	Default	Unit	Property
F3-08	Special deceleration rate	0.200–1.500	0.900	m/s ²	★

It is used to set the deceleration rate in elevator slow-down, inspection, and shaft auto-tuning.

This parameter is not used during normal running. It is used only when the elevator position is abnormal or the slow-down signal is abnormal, preventing over travel top terminal or over travel bottom terminal.

Function Code	Parameter Name	Setting Range	Default	Unit	Property
F3-09	Pre-deceleration distance	0–90.0	0.0	mm	★

It is used to set the pre-deceleration distance of the elevator in distance control, as shown in Figure 7-2. This function is to eliminate the effect of encoder signal loss or leveling signal delay.

Function Code	Parameter Name	Setting Range	Default	Unit	Property
F3-10	Re-leveling speed	0.000–0.080	0.040	m/s	★

is used to set the elevator speed during re-leveling.

This parameter is valid only when the pre-open module (MCTC-SCB-A) is added to implement the re-leveling function (set in FE-32).

Function Code	Parameter Name	Setting Range	Default	Unit	Property
F3-11	Inspection speed	0.100–0.630	0.250	m/s	★

It is used to set the elevator speed during inspection and shaft auto-tuning.

Function Code	Parameter Name	Setting Range	Default	Unit	Property
F3-12	Position of up slow-down 1	0.000–300.00	0.00	m	★
F3-13	Position of down slow-down 1	0.000–300.00	0.00	m	★
F3-14	Position of up slow-down 2	0.000–300.00	0.00	m	★
F3-15	Position of down slow-down 2	0.000–300.00	0.00	m	★
F3-16	Position of up slow-down 3	0.000–300.00	0.00	m	★
F3-17	Position of down slow-down 3	0.000–300.00	0.00	m	★

These parameters specify the positions of all slow-down switches relative to the bottom leveling position, and the positions are automatically recorded during shaft auto-tuning. For the installation positions of the slow-down switches, see the description of section 3.8.2.

The NICE3000^{new} integrated elevator controller supports a maximum of three pairs of slow-down switches. From two sides of the shaft to the middle, slow-down 1, slow-down 2, and slow-down 3 are installed in order; that is, slow-down 1 is installed near the terminal floor. There may be only one pair of slow-sown switches for the low-speed elevator, and two or three pairs of slow-down switches for the high-speed elevator.

The system automatically detects the speed when the elevator reaches a slow-down switch. If the detected speed or position is abnormal, the system enables the elevator to slow down at the special deceleration rate set in F3-08, preventing over travel top terminal or over travel bottom terminal.

Function Code	Parameter Name	Setting Range	Default	Unit	Property
F3-18	Zero-speed control time at startup	0.000–1.000	0.200	s	★
F3-19	Brake release delay	0.000–2.000	0.600	s	★
F3-20	Zero-speed control time at end	0.000–1.000	0.300	s	★

These parameters are used to set the time related to the zero-speed holding current output and braking action delay.

- F3-18 (Zero-speed control time at startup) specifies the time from output of the RUN contactor to output of the brake contactor, during which the controller performs excitation on the motor and outputs zero-speed current with large startup torque.

- F3-19 (Brake release delay) specifies the time from the moment when the system sends the brake release command to the moment when the brake is completely released, during which the system retains the zero-speed torque current output.
- F3-20 (Zero-speed control time at end) specifies the zero-speed output time when the running curve ends.
- F8-11 (Brake apply delay) specifies the time from the moment when the system sends the brake apply command to the moment when the brake is completely applied, during which the system retains the zero-speed torque current output.

Figure 7-3 Running time sequence

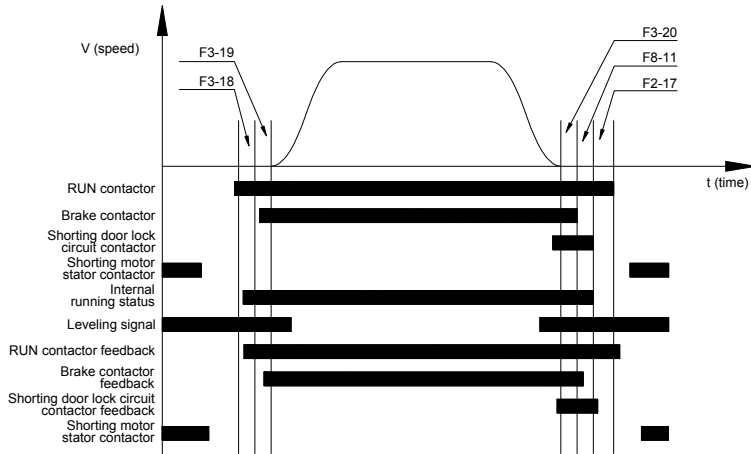

Function Code	Parameter Name	Setting Range	Default	Unit	Property
F3-21	Low-speed re-leveling speed	0.080 to F3-11	0.100	m/s	★

It is used to set the elevator speed of returning to the leveling position at normal non-leveling stop.

Function Code	Parameter Name	Setting Range	Default	Unit	Property
F3-22	Acceleration rate at emergency evacuation	0.100–1.300	0.100	m/s ²	★

It is used to set the acceleration rate at emergency evacuation.

Function Code	Parameter Name	Setting Range	Default	Unit	Property
F3-24	Program function selection	0: Reserved 1: Slip experiment enabled	0	-	★

This parameter is used when the motor slip experiment is performed during elevator acceptance. If the slip experiment onsite is not successful, set this parameter to 1 to enable the slip experiment function. After the experiment is completed, restore the parameter to disable the function.

Group F4: Floor Parameters

Function Code	Parameter Name	Setting Range	Default	Unit	Property
F4-00	Leveling adjustment	0–60	30	mm	★

It is used to adjust the leveling accuracy at elevator stop. If over-leveling occurs at all floors during elevator stop, decrease the value of this parameter properly. If under-leveling occurs at all floors during elevator stop, increase the value of this parameter properly.

This parameter takes effect to leveling of all floors. Therefore, if leveling at a single floor is inaccurate, adjust the position of the leveling plate.

The NICE3000^{new} has the advanced distance control algorithm and adopts many methods to ensure reliability of direct travel ride. Generally you need not modify this parameter.

Function Code	Parameter Name	Setting Range	Default	Unit	Property
F4-01	Current floor	F6-01 to F6-00	1	-	★

This parameter indicates the current floor of the elevator car.

The system automatically changes the value of this parameter during running, and corrects it at leveling position (door open limit) after the up slow-down and down slow-down switches act. At non-bottom floor and top-floor leveling, you can also manually modify this parameter, but the value must be consistent with the actual current floor.

Function Code	Parameter Name	Setting Range	Default	Unit	Property
F4-02	High byte of current floor position	0–65535	1	Pulses	●
F4-03	Low byte of current floor position	0–65535	34464	Pulses	●

These two parameters indicate the absolute pulses of the current position of the elevator car relative to the bottom leveling position.

The position data of the NICE3000^{new} in the shaft is recorded in pulses. Each position is expressed by a 32-bit binary number, where the high 16 bits indicate the high byte of the floor position, and the low 16 bits indicate the low byte of the floor position.

Function Code	Parameter Name	Setting Range	Default	Unit	Property
F4-04	Length 1 of leveling plate	0–65535	0	mm	★
F4-05	Length 2 of leveling plate	0–65535	0	mm	★

These two parameters respectively indicate the pulses corresponding to the length of the magnetic value and the length between two leveling sensors. They are automatically recorded during shaft auto-tuning.

Function Code	Parameter Name	Setting Range	Default	Unit	Property
F4-06	High byte of floor height 1	0–65535	0	Pulses	★
F4-07	Low byte of floor height 1	0–65535	0	Pulses	★
...(Floor height 2 to floor height 38)					
F4-82	High byte of floor height 39	0–65535	0	Pulses	★
F4-83	Low byte of floor height 39	0–65535	0	Pulses	★

These parameters indicate the pulses corresponding to the floor height i (between the leveling plates of floor n and floor $i+1$). Each floor height is expressed by a 32-bit binary number, where the high 16 bits indicate the high byte of the floor height, and the low 16 bits indicate the low byte of the floor height. On normal conditions, the floor height i of each floor is almost the same.

Group F5: Terminal Function Parameters

Function Code	Parameter Name	Setting Range	Default	Unit	Property
F5-00	Attendant/Automatic switchover time	3–200	3	s	★

If there is a hall call at current floor in attendant state, the system automatically switches over to the automatic (normal) state after the time set in this parameter. After this running is completed, the system automatically restores to the attendant state (Bit2 of F6-43 must be set to 1). When the value of this parameter is smaller than 5, this function is disabled, and the system is in the normal attendant state.

Function Code	Parameter Name	Setting Range	Default	Unit	Property
F5-01	X1 function selection	0–127	33	-	★
F5-02	X2 function selection		35	-	★
F5-03	X3 function selection		34	-	★
	
F5-23	X23 function selection		00	-	★
F5-24	X24 function selection		00	-	★

These parameters are used to set the functions of input terminals X1 to X24.

Note

Functions 04/36 (Safety circuit feedback NO/NC input), 05/37 (Door lock circuit feedback NO/NC input), 06/38 (Main contactor feedback NO/NC input), 07/39 (Brake feedback contactor NO/NC input), 26/58 (Brake contactor feedback 2 NO/NC input) can be repeatedly allocated to the input terminals.

Terminals X1 to X24 are digital inputs, and are allocated with corresponding functions based on the input signals. All these terminals share the COM terminal. After the 24 V voltage is input, the corresponding input terminal indicator becomes ON. The functions are described as follows:

00: Invalid

Even if there is signal input to the terminal, the system has no response. You can allocate this function to terminals that are not used to prevent mis-function.

01: Up leveling signal 02: Down leveling signal 03: Door zone signal

The NICE3000^{new} system determines the elevator leveling position based on the leveling sensor signal. The system supports three types of leveling configuration: single door zone sensor, up and down leveling sensors, and door zone sensor plus the up/down leveling sensor.

The following table describes the sequence of received signals for the three types of leveling configurations.

Leveling Configuration			Signal Receiving Sequence	
Up leveling sensor	Down leveling sensor	Door zone sensor	Up direction	Down direction
No	No	Yes	Door zone signal	
Yes	Yes	No	Up leveling signal → Down leveling signal	Down leveling signal → Up leveling signal
Yes	Yes	Yes	Up leveling signal → Door zone signal → Down leveling signal	Down leveling signal → Door zone signal → leveling signal

If the leveling signal is abnormal (stuck or unavailable), the system reports fault Err22.

04: Safety circuit feedback signal 05: Door lock circuit feedback signal

29: Safety circuit 2 feedback signal 31: Door lock circuit 2 feedback signal

The safety circuit is important to safe and reliable running of the elevator, and the door lock circuit ensures that the hall door and car door are closed before the elevator starts to run. Valid feedback signals of the safety circuit and door lock circuit are necessary to elevator running.

It is recommended that these signals are set to NO input. If they are set to NC input, the system considers the input active even though there is no input. In this case, the actual state of the safety circuit cannot be detected, which may cause potential safety risks.

06: RUN contactor feedback signal 07: Brake contactor feedback signal

26: Brake travel switch input signal 78: Brake travel switch 2 input signal

The system sends commands to the RUN and brake contactors and automatically detects the feedback from the RUN and brake contactors. If the commands and the feedback are inconsistent, the system reports a fault.

08: Inspection signal 09: Inspection up signal 10: Inspection down signal

When the Automatic/Inspection switch is set to the Inspection position, the elevator enters the inspection state; in this case, the system cancels all automatic running including the automatic door operations. When the inspection up signal or inspection down signal is valid, the elevator runs at the inspection speed.

11: Fire emergency signal

When the fire emergency switch is turned on, the elevator enters the fire emergency state, and immediately cancels the registered hall calls and car calls. The elevator stops at the nearest floor without opening the door, and then directly runs to the fire emergency floor and automatically opens the door after arrival.

12: Up limit signal 13: Down limit signal

The up limit signal and down limit signal are used as the stop switches at the terminal floor to prevent over travel top terminal or over travel bottom terminal when the elevator runs over the leveling position of the terminal floor but does not stop.

14: Overload signal

When the elevator load exceeds 110% of the rated load during normal use, the elevator enters the overload state. Then the overload buzzer beeps, the overload indicator in the car becomes ON, and the elevator door keeps open. The overload signal becomes invalid when the door lock is applied. If the running with 110% of the rated load is required during inspection, you can set F7-06 to 1 to allow overload running (note that this function has potential safety risks and use it with caution).

It is recommended that the overload signal be set to NC input. If it is set to NO, the system cannot detect the overload state when the overload switch is damaged or the connection is broken, and the elevator running in this case may cause potential safety risks. It is also recommended that the up limit signal, down limit signal, and slow-down signal are set to NC.

15: Full-load signal

When the elevator load is 80% to 110% of the rated load, the HOP displays the full-load state, and the elevator does not respond to hall calls.

Note

When terminal X on the MCB is used for input of the overload and full-load signals, ensure that F5-36 has been set to 0.

16: Up slow-down 1 signal 17: Down slow-down 1 signal**18: Up slow-down 2 signal 19: Down slow-down 2 signal****20: Up slow-down 3 signal 21: Down slow-down 3 signal**

The slow-down signals are used to enable the elevator to stop at the slow-down speed when the car position is abnormal, which is an important method to guarantee elevator safety. The system automatically records the positions of the switches in group F3 during shaft auto-tuning.

22: Shorting door lock circuit contactor feedback

It is the feedback signal when the door lock circuit is shorted at if the function of door pre-open upon arrival or re-leveling at door open is enabled for the elevator configured with the pre-open module. This is to ensure safety during the elevator running.

23: Firefighter switch signal

It is the firefighter switch signal and is used to enable the firefighter running. After the elevator returns to the fire emergency floor, the elevator enters the firefighter running state if the firefighter signal is active.

24: Door machine 1 light curtain signal 25: Door machine 2 light curtain signal

They are used to detect the light curtain signals of door machine 1 and door machine 2 (if existing).

27: UPS valid signal

It is the emergency running signal at power failure. If it is active, it indicates that the elevator is running for emergency evacuation at power failure. For more details, see section 5.2.1.

28: Elevator lock signal

If this signal is active, the elevator enters the locked state, returns to the elevator lock floor and does not respond to any calls until the signal becomes inactive. It has the same function as the hall call elevator lock signal.

30: Shorting PMSM stator feedback signal

The shorting PMSM stator contactor protects the elevator from falling at high speed in the case of brake failure. This signal is used to monitor whether the shorting PMSM stator contactor is normal.

65: Door machine 1 safety edge signal 66: Door machine 2 safety edge signal

They are used to detect the safety edge signal state of door machine 1 and door machine 2 (if existing).

67: Motor overheat signal

If this signal remains active for more than 2s, the controller stops output and reports fault Err39 to prompt motor overheat. After this signal becomes inactive, Err39 is reset automatically and the system resumes to normal operation.

68: Earthquake signal

If this signal remains active for more than 2s, the elevator enters the earthquake stop state, stops at the nearest landing floor and opens the door. Then the elevator starts running again after the earthquake signal becomes inactive.

69: Back door forbidden signal

If double door machines are applied, it is used to prohibit the use of door machine 2.

70: Light-load signal

It is used for nuisance judgment in the anti-nuisance function. If Bit2 in F8-08 is set to 1, the system performs nuisance judgment by using the light-load switch. The load below 30% of the rated load is regarded as light load.

71: Half-load signal

It is used for allocation of elevators in parallel or group mode and judgment of the emergency running direction at power failure.

72: Fire emergency floor switchover signal

76: Door 1 open input 77: Door 2 open input

The NICE3000^{new} supports two fire emergency floors. By default, the elevator stops at fire emergency floor 1 in fire emergency state. If this signal is active, the elevator stops at fire emergency floor 2 in fire emergency state.

Function Code	Parameter Name	Setting Range	Default	Unit	Property
F5-25	CTB input type	0-511	320	-	★

It is used to define the input signal type (NO/NC) of the CTB by binary bit.

For example, the input signal types of the CTB of an elevator are set as follows:

Bit	Parameter Name	Default	Bit	Parameter Name	Default
Bit0	Door machine 1 light curtain	0	Bit5	Door machine 2 close limit	0
Bit1	Door machine 2 light curtain	0	Bit6	Full-load signal (digital)	1
Bit2	Door machine 1 open limit	0	Bit7	Overload signal (digital)	0
Bit3	Door machine 2 open limit	0	Bit8	Light-load signal (digital)	1
Bit4	Door machine 1 close limit	0	0: NC input; 1: NO input		

Function Code	Parameter Name	Setting Range	Default	Unit	Property
F5-26	Y1 function selection	0-31	1	-	★
F5-27	Y2 function selection		2	-	★
F5-28	Y3 function selection		3	-	★
F5-29	Y4 function selection		4	-	★
F5-30	Y5 function selection		0	-	★
F5-31	Y6 function selection		0	-	★

These parameters are used to set the functions of relay output terminals Y1 to Y6.

00: Invalid

The terminal has no function.

01: RUN contactor control 02: Brake contactor control 03: Shorting door lock circuit contactor control

The terminal with one of these functions controls whether the contactor is opened or closed.

04: Fire emergency floor arrival signal feedback

In the fire emergency state, the system sends the feedback signal for monitoring after the elevator stops at the fire emergency floor.

05: Door machine 1 open 06: Door machine 1 close 07: Door machine 2 open 08: Door machine 2 close

The terminal with one of these functions is used to control open and close of door 1 or 2.

09: Brake and RUN contactors healthy

When the brake and RUN contactors operate properly (non-Err36/Err37 state), the system sends the feedback signal for monitoring.

10: Fault state

The terminal with the function has output when the system is in the level-3, level-4 or level-5 fault state.

11: Running monitor

The terminal with the function has output when the controller is running.

12: Shorting PMSM stator contactor

When the shorting PMSM stator contactor is applied in synchronous motor, the terminal with the function is used to control whether the contactor is closed or opened. For details, see section 5.2.1.

13: Emergency evacuation automatic switchover

When detecting that the bus voltage declines to a certain value after power failure occurs on the mains supply, the controller outputs this signal and uses the battery for temporary power supply, implementing emergency evacuation running.

Only Y6/M6 can be allocated with this function because the controller needs to depend on its residual power to drive the relay at power failure of the mains supply.

14: System healthy

The terminal with the function has output when the system operates properly.

15: Emergency buzzer control

The terminal with the function has output when the system is in the emergency evacuation running state. The buzzer tweets to prompt.

16: Higher-voltage startup of brake

This function is used for the brake that keeps the release state with voltage reduction. The terminal with this function keeps the output for 4s to release the brake, and then the voltage is reduced to keep the brake release state.

17: Elevator running in up direction

The terminal with the function has output when the elevator runs in the up direction.

18: Lamp/Fan running

It is used for the lamp/fan running output, the same as the energy saving control output of the CTB.

19: Medical sterilization

It is used to control the output of the ultraviolet sterilizing lamp signal. After the elevator stops running and the lamp/fan stops operating, the medical sterilization output is started.

20: Non-door zone stop

The terminal with this function has output when the elevator stops at the non-door zone.

21: Electric lock

It is used to control applying and releasing of the electric lock in the case of manual door.

22: Non-service state

It is output when the elevator is in the non-service state and cannot respond to hall calls.

Function Code	Parameter Name	Setting Range	Default	Unit	Property
F5-32	Communication state display	Monitoring of CANbus and Modbus communication states	-	-	●

It is used to monitor the state of CANbus communication with the CTB and Modbus communication with the HOP.

When you enter the menu of F5-32, the LEDs on the operation panel indicate the current HOP communication state. The LEDs are arranged as 5, 4, 3, 2, 1 from left to right.

Figure 7-4 Communication state monitoring

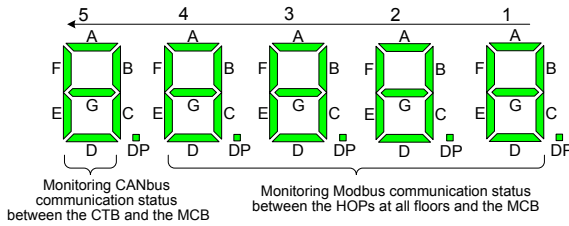

Each segment of the LEDs is defined in the following table.

Table 7-2 Definition of LED segments

LED No.	Corresponding Normal Modbus Communication Address of LED								Meaning of Segment ON
	A	B	C	D	E	F	G	DP	HOP Modbus Communication Normal
1	1	2	3	4	5	6	7	8	
2	9	10	11	12	13	14	15	16	
3	17	18	19	20	21	22	23	24	
4	25	26	27	28	29	30	31	Reserved	
LED No.	Corresponding Abnormal Modbus Communication Address of LED								Meaning of Segment OFF
	A	B	C	D	E	F	G	DP	HOP Modbus Communication Abnormal
1	1	2	3	4	5	6	7	8	
2	9	10	11	12	13	14	15	16	
3	17	18	19	20	21	22	23	24	
4	25	26	27	28	29	30	31	Reserved	
LED No.	CTB CANbus Communication State								Number Displayed by the LED
5	<p style="text-align: center;">Best communication status → Communication interrupted</p> <p style="text-align: center;">0 1 2 3 4 5 6 7 8 9</p> <p style="text-align: center;">Communication status from strong to weak</p>								

For example, if the LEDs are shown as the following figure, it indicates that the Modbus communication of addresses 1, 5, 6, 7, 12, 15, 16, 18, 19, 21, 22, 23, 25, 26 and 27 are abnormal. The Modbus communication of other addresses is normal. The CANbus communication state displayed by the LED is 3, indicating normal communication.

Figure 7-5 Example of LED display indicating the communication state

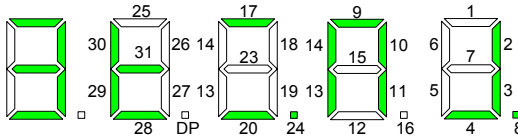

Function Code	Parameter Name	Setting Range	Default	Unit	Property
F5-33	Terminal program control	0-65535	0	-	★

It is used to set the elevator functions. Whether a function is enabled is indicated by a binary bit: "1" indicates that the function is enabled, and "0" indicates that the function is disabled. The functions defined by the binary bits are described in the following table.

Table 7-3 Functions indicated by bits of F5-33

Bit	Function	Description	Default
Bit3	Elevator fire emergency requirement for Hong Kong	If it is enabled, the fire emergency functions in F6-44 applied to Hong Kong become enabled automatically.	0
Bit4	Arrival gong disabled at night	The arrival gong is disabled from 22:00 p.m. to 7:00 a.m.	0
Bit6	Door lock disconnected at inspection switched over to normal running	The door lock is additionally disconnected once when the inspection state is switched over to the normal running state.	0
Bit7	Fault code not displayed on the keypad	The keypad does not blink to display the fault code.	0
Bit8	Door open command cancelled immediately at door open limit	The system immediately cancels the door open command after receiving the door open limit.	0
Bit9	Car stop and zero-speed torque holding at abnormal brake feedback	When the brake feedback is abnormal, the elevator arrives at the door-zone position and stops. The door keeps closed, and the system holds torque output as long as possible. After the system is overloaded, there is no torque output, and the elevator may fall in this case. Be cautious of using this function.	0

Function Code	Parameter Name	Setting Range	Default	Unit	Property
F5-34	Terminal state display	Monitoring of I/O terminals on MCB	-	-	●
F5-35	Terminal state display	Monitoring of I/O terminals on CTB, CCB and HOP	-	-	●

These parameters are used to monitor the state of all I/O terminals of the system.

The LEDs of F5-34/F5-35 are arranged as 5, 4, 3, 2, 1 from left to right.

Figure 7-6 Monitoring of all I/O terminals

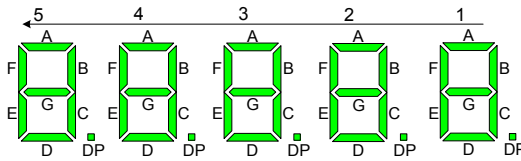

Each segment of the LEDs is defined in the following table.

Table 7-4 Definition of LED segments

F5-34			F5-35		
No.	Segment	Indication	No.	Segment	Indication
1	A	-	1	A	Light curtain 1
	B	Up leveling signal		B	Light curtain 2
	C	Down leveling signal		C	Door 1 open limit
	D	Door zone signal		D	Door 2 open limit
	E	Safety circuit feedback 1		E	Door 1 close limit
	F	Door lock circuit feedback 1		F	Door 2 close limit
	G	RUN contactor feedback		G	Full-load signal
	DP	Brake contactor feedback 1		DP	Overload signal
2	A	Inspection signal	2	A	Door open button
	B	Inspection up signal		B	Door close button
	C	Inspection down signal		C	Door open delay button
	D	Fire emergency signal		D	Direct travel ride signal
	E	Up limit signal		E	Attendant signal
	F	Down limit signal		F	Direction change signal
	G	Overload signal		G	Independent running signal
	DP	Full-load signal		DP	Firefighter operation signal
3	A	Up slow-down 1 signal	3	A	Door open output 1
	B	Down slow-down 1 signal		B	Door close output 1
	C	Up slow-down 2 signal		C	Door lock signal
	D	Down slow-down 2 signal		D	Door open output 2
	E	Up slow-down 3 signal		E	Door close output 2
	F	Down slow-down 3 signal		F	Door lock signal
	G	Shorting door lock circuit contactor feedback		G	Up arrival gong
	DP	Firefighter running signal		DP	Down arrival gong

F5-34			F5-35		
No.	Segment	Indication	No.	Segment	Indication
4	A	Door machine 1 light curtain	4	A	Door open button display
	B	Door machine 2 light curtain		B	Door close button display
	C	Brake contactor feedback 2		C	Door open delay button display
	D	UPS input		D	Non-door zone stop
	E	Elevator lock input		E	Reserved
	F	Safety circuit feedback 2		F	Buzzer output
	G	Shorting PMSM stator contactor feedback		G	Reserved
	DP	Door lock circuit feedback 2		DP	Energy saving sign
5	A	Reserved	5	A	System light curtain state 1
	B	RUN contactor output		B	System light curtain state 2
	C	Brake contactor output		C	Hall call elevator lock input
	D	Shorting door lock circuit contactor control		D	Hall call fire emergency input
	E	Fire emergency floor arrival signal		E	Full-load signal
	F	-		F	Overload signal
	DP	-		DP	-

Function Code	Parameter Name	Setting Range	Default	Unit	Property
F5-36	Load cell input selection	0-3	1	-	★

It is used to set the channel of setting the elevator load cell signal. When a load cell device is used, set this parameter correctly first.

The values are as follows:

- 0: Invalid
- 1: CTB digital input
- 2: CTB analog input
- 3: MCB analog input

Function Code	Parameter Name	Setting Range	Default	Unit	Property
F5-37	X25 function selection	0: No function	0	-	★
F5-38	X26 function selection	4: Safety circuit signal	0	-	★
F5-39	X27 function selection	5: Door lock circuit signal	0	-	★

These parameters are used to set the functions of heavy-current detection input terminals X25 to X27.

The functions 0, 4, and 5 can be repeatedly allocated to terminals. If X25 to X27 are not used, cancel the setting of these parameters.

Group F6: Basic Elevator Parameters

Function Code	Parameter Name	Setting Range	Default	Unit	Property
F6-00	Top floor of the elevator	F6-01 to 40	9	-	★
F6-01	Bottom floor of the elevator	1 to F6-00	1	-	★

These two parameters are used to set the top floor and bottom floor of the elevator, determined by the number of actually installed leveling plates.

Function Code	Parameter Name	Setting Range	Default	Unit	Property
F6-02	Parking floor	F6-01 to F6-00	1	-	★

When the idle time of the elevator exceeds the value set in F9-00, the elevator returns to the parking floor automatically.

Function Code	Parameter Name	Setting Range	Default	Unit	Property
F6-03	Fire emergency floor	F6-01 to F6-00	1	-	★

When entering the state of returning to the fire emergency floor, the elevator returns to this floor.

Function Code	Parameter Name	Setting Range	Default	Unit	Property
F6-04	Elevator lock floor	F6-01 to F6-00	1	-	★

When entering the elevator lock state, the elevator returns to this floor.

Function Code	Parameter Name	Setting Range	Default	Unit	Property
F6-05	Service floors 1	0–65535 (floors 1–16)	65535	-	★
F6-06	Service floors 2	0–65535 (floors 17–32)	65535	-	★
F6-35	Service floors 3	0–65535 (floors 33–40)	65535	-	★

These parameters are used to set the service floors among floors 1–40. F6-05 (Service floors 1) corresponds to floors 1–16. F6-06 (Service floors 2) corresponds to floors 17–32. F6-35 (Service floors 3) corresponds to floors 33–40.

Set these parameters as follows:

Whether service floors of a parameter are allowed is indicated by a 16-bit binary number. The 16 bits respectively correspond to 16 floors from low to high. "1" indicates that the elevator will respond to calls of this floor, and "0" indicates that the elevator will not respond to calls of this floor.

For example, the service floors of a 16-floor elevator are listed in the following table.

Table 7-5 Service floors of a 16-floor elevator

Bit	Floor	Whether Service	Setting	Bit	Floor	Whether Service	Setting
Bit0	Floor 1	Allowed	1	Bit8	Floor 9	Forbidden	0
Bit1	Floor 2	Forbidden	0	Bit9	Floor 10	Allowed	1

Bit	Floor	Whether Service	Setting	Bit	Floor	Whether Service	Setting
Bit2	Floor 3	Allowed	1	Bit10	Floor 11	Allowed	1
Bit3	Floor 4	Allowed	1	Bit11	Floor 12	Forbidden	0
Bit4	Floor 5	Allowed	1	Bit12	Floor 13	Allowed	1
Bit5	Floor 6	Allowed	1	Bit13	Floor 14	Allowed	1
Bit6	Floor 7	Allowed	1	Bit14	Floor 15	Allowed	1
Bit7	Floor 8	Forbidden	0	Bit15	Floor 16	Allowed	1

The binary number indicated by the preceding table is 1111011001111101. The decimal equivalent of this binary number is 63101. Then set F6-05 to 63101.

Function Code	Parameter Name	Setting Range	Default	Unit	Property
F6-07	Number of elevators in parallel/group mode	1–8	1	-	★
F6-08	Elevator No.	1–8	1	-	★

These parameters are used to set the number of elevators and elevator No. in parallel/group mode.

Note

- If F6-07 is set to 1, the setting of F6-08 becomes invalid.
- Elevator No.1 is the master elevator in parallel/group mode and completes the most parallel logics.

Function Code	Parameter Name	Setting Range	Default	Unit	Property
F6-09	Elevator program control	0–65535	0	-	★

It is used to select the required elevator functions. Whether a function is enabled is indicated by a binary bit: "1" indicates that the function is enabled, and "0" indicates that the function is disabled.

The functions defined by the binary bits are described in the following table.

Table 7-6 Functions indicated by bits of F6-09

Bit	Function	Description	Default
Bit0	Dispersed waiting	In single elevator or parallel/group mode, if this function is enabled, an idle elevator will not return to the base floor. In group mode, this function is used together with the group control board to implement dispersed waiting.	0
Bit3	Parallel/Group control implemented at CAN2	This function is enabled when the parallel/group mode is implemented at CAN2.	0

Bit	Function	Description	Default
Bit4	Group control in compatibility with NICE3000	This function is used when the NICE3000 is involved in the group control system. The setting of this bit must be the same as that for all the other elevators in the group.	0
Bit6	Clear floor number and display direction in advance	The displayed floor number is cleared before the elevator reaches the target floor. If the elevator needs to change the direction, the changed direction is displayed in advance.	0
Bit8	Single hall call button	It is applied to applications where there is only one hall call button.	0
Bit9	Not detecting analog wire breaking	The system does not detect analog wire breaking during normal running.	0
Bit10	Err30 judgment at re-leveling cancellation	It indicates Err30 judgment when re-leveling is cancelled.	0
Bit14	Time interval detection of safety circuit 2 and door lock circuit 2	If the states of safety circuits 1 and 2 or the states of door lock circuits 1 and 2 are inconsistent, the system will prohibit running. After the states restore normal, the system is powered on again and starts running.	0

Function Code	Parameter Name	Setting Range	Default	Unit	Property
F6-10	Leveling sensor filter time	10-50	14	ms	★

It indicates the delay time from the moment when the leveling sensor acts to the moment when the leveling signal becomes active. You need not modify it.

Function Code	Parameter Name	Setting Range	Default	Unit	Property
F6-11	Elevator function selection	0-65535	8448	-	★

It is used to set the elevator functions. "1" indicates that the function is enabled, and "0" indicates that the function is disabled.

The functions defined by the binary bits are described in the following table.

Table 7-7 Functions indicated by bits of F6-11

Bit	Function	Description	Default
Bit1	Disabling returning to base floor for verification	The function of returning to base floor for verification due to large deviation of the car position is disabled.	0
Bit2	Cancelling auto sequential arrange of hall call floor addresses to be displayed	If the display of a floor in group FE is set to 1, the following floors to be displayed are automatically arranged in the ascending order.	0
Bit5	Current detection valid at startup for synchronous motor	The controller performs output current detection when the synchronous motor is started up. If the current is abnormal, the output will be locked and the running will be forbidden.	0

Bit	Function	Description	Default
Bit6	Reversing MCB lamp output	After this function is enabled, the MCB lamp output logic is reversed.	0
Bit7	Door open valid at non-door zone in the inspection state	In the inspection state, you can open/close the door by pressing the door open/close button at the non-door zone.	0
Bit8	Door open and close once after inspection turned to normal	The elevator door opens and closes once after the system turns from first-time inspection to normal running.	1
Bit10	Buzzer not tweet upon re-leveling	The buzzer inside the car does not tweet upon re-leveling.	0
Bit11	Super short floor function	The controller cannot perform shaft-tuning if the floor height is less than 500 mm. After this function is enabled, shaft-tuning can be performed normally.	0
Bit12	Fault auto reset	The controller automatically resets the faults once every hour.	0
Bit13	Err53 fault auto reset	When Err53 is reported, if the conditions of door open limit valid and door lock release are satisfied, the controller resets Err53 automatically. A maximum of three times of auto reset is allowed.	1
Bit14	Up slow-down not reset for super short floor	If this function is enabled, the up slow-down 1 signal does not reset floor display. The down slow-down 1 signal still resets floor display. This is valid only when the customized super short floor function is enabled.	0
Bit15	Down slow-down not reset for super short floor	If this function is enabled, the down slow-down 1 signal does not reset floor display. The up slow-down 1 signal still resets floor display. This is valid only when the customized super short floor function is enabled.	0

Function Code	Parameter Name	Setting Range	Default	Unit	Property
F6-12	VIP floor	0 to F6-00	0	-	★

It is used to set the VIP floor. For details, see section 5.2.4.

Function Code	Parameter Name	Setting Range	Default	Unit	Property
F6-13	Security floor	0 to F6-00	0	-	★

It is used to set the security floor of the elevator. If the security signal is active or it is during the night security period, the elevator runs to the security floor first every time, stops and opens the door, and then runs to the target floor.

The elevator can be made to stop at the security floor in the following two ways:

- Fd-07/Fd-08 is set to 5 (Security signal). If the security signal is active, the elevator enters the security state.
- The night security floor function is enabled (FE-32 Bit5 = 2), the elevator enters the security state from 22:00 p.m. to 6:00 a.m.

Function Code	Parameter Name	Setting Range	Default	Unit	Property
F6-14	Start time of down collective selective 1	00.00–23.59	00.00	HH.MM	☆
F6-15	End time of down collective selective 1	00.00–23.59	00.00	HH.MM	☆
F6-16	Start time of down collective selective 2	00.00–23.59	00.00	HH.MM	☆
F6-17	End time of down collective selective 2	00.00–23.59	00.00	HH.MM	☆

These four parameters define the time periods of down collective selective 1 and down collective selective 2, during which, the elevator responds to only downward hall calls.

Function Code	Parameter Name	Setting Range	Default	Unit	Property
F6-18	Start time of time-based floor service 1	00.00–23.59	00.00	HH.MM	☆
F6-19	End time of time-based floor service 1	00.00–23.59	00.00	HH.MM	☆
F6-20	Service floor 1 of time-based floor service 1	0–65535	65535	-	☆
F6-21	Service floor 2 of time-based floor service 1	0–65535	65535	-	☆
F6-36	Service floor 3 of time-based floor service 1	0–65535	65535	-	☆
F6-22	Start time of time-based floor service 2	00.00–23.59	00.00	HH.MM	☆
F6-23	End time of time-based floor service 2	00.00–23.59	00.00	HH.MM	☆
F6-24	Service floor 1 of time-based floor service 2	0–65535	65535	-	☆
F6-25	Service floor 2 of time-based floor service 2	0–65535	65535	-	☆
F6-37	Service floor 3 of time-based floor service 2	0–65535	65535	-	☆

These parameters define the time periods of two groups of time-based services and corresponding service floors.

Service floor 1 corresponds to floors 1–16, service floor 2 corresponds to floors 17–32, and service floor 3 corresponds to floors 33–30.

In the time period of time-based service 1 (set by F6-18 and F6-19), the elevator responds to the service floors set by F6-20, F6-21 and F6-36 but ignores the service floors set by F6-05, F6-06 and F5-35. The setting of time-based service floors is the same as that of service floors in F6-05.

Note

During the time-based floor service period, the settings of F6-05, F6-06 and F5-35 are invalid.

If the two periods of time-based floor service 1 and time-based floor service 2 are overlapped, the system implements time-based floor service 1 because it has higher priority level.

Function Code	Parameter Name	Setting Range	Default	Unit	Property
F6-26	Peak 1 start time	00.00–23.59	00.00	HH.MM	☆
F6-27	Peak 1 end time	00.00–23.59	00.00	HH.MM	☆
F6-28	Peak 1 floor	F6-01 to F6-00	1	-	★
F6-29	Peak 2 start time	00.00–23.59	00.00	HH.MM	☆
F6-30	Peak 2 end time	00.00–23.59	00.00	HH.MM	☆
F6-31	Peak 2 floor	F6-01 to F6-00	1	-	★

These parameters define two peak time periods in parallel/group mode and corresponding floors. During a peak time period, if there are more than three car calls from the peak floor, the elevator enters the peak service state. At the moment, the car calls from the peak floor are valid all the time. The elevator returns to this floor if it is idle.

Function Code	Parameter Name	Setting Range	Default	Unit	Property
F6-38	Elevator lock start time	00.00–23.59	00.00	HH.MM	☆
F6-39	Elevator lock end time	00.00–23.59	00.00	HH.MM	☆

These two parameters define the elevator lock time period, during which automatic elevator lock has the same effect as elevator lock by means of the elevator lock switch.

Function Code	Parameter Name	Setting Range	Default	Unit	Property
F6-40	Program control selection 1	0–65535	0	-	★
F6-41	Program control selection 2	0–65535	0	-	★
F6-42	Program control selection 3	0–65535	0	-	★

These parameters are used to set program control functions. "1" indicates that the function is enabled, and "0" indicates that the function is disabled.

The functions defined by the binary bits are described in the following table.

Table 7-8 Functions indicated by the bits of F6-40 to F6-42

F6-40 Program Control Selection 1			
Bit	Function	Description	Default
Bit0	Disability function	It is used to enable or disable the disability function.	0
Bit1	Soft limit function	When the up slow-down and down leveling signals are active and the up leveling signal is inactive, the system considers that the up limit is performed. It is the same for the down limit signal.	0
Bit2	JP16 input used as back door selection	This function is enabled if the opposite door function is used. When JP16 has input, the elevator opens only the back door. When IP16 has no input, the elevator opens only the front door.	0
Bit3	JP16 input used as the back door open signal	JP16 is used for the input of the back door open signal.	0

F6-40 Program Control Selection 1			
Bit	Function	Description	Default
Bit4	Opening only one door of opposite doors under manual control	This function is enabled only in the opposite door control mode 2 (hall call independent, opposite-door manual control). In this case, only one door opens each time while the other door must stay in the door close limit state. In group Fd, the HCB-B extended input includes "Single/Double door selection". If this input is active, both doors open if there is a car call.	0
Bit5	Timed elevator lock	F6-38/F6-39 is valid only when this function is enabled.	0
Bit6	Manual door	This function is used for the elevator with manual door.	0
Bit7	Reserved	-	0
Bit8	Reserved	-	0
Bit9	Disabling reverse floor number clear	The system clears all the current car calls every time the elevator changes the direction by default. When this function is enabled, the function of clearing reverse floor numbers is disabled.	0
Bit10	Displaying next arriving floor number	The next floor to be arrived at is displayed during elevator running.	0
Bit11	Responding to car calls first	The system responds to hall calls only after executing all car calls.	0
Bit12	Car call assisted command in single door used as disability function	You can set the auxiliary command terminal (CN8) on the CTB for input of the disability calls (folding command not required).	0
Bit13	Folding command used as disability function and back door function	It is valid only when the function of Bit14 is enabled. Bit13 = 1: Disability Bit13 = 0: Back door	0
Bit14	Car call command folding	Function disabled: CN7 is used for front door calls or ordinary calls, and CN8 is used for back door calls or disability calls. Function enabled: For CN7 and CN8, inputs 1 to 16 are used for front door calls or ordinary calls, and inputs 17 to 32 are used for back door calls or disability calls.	0
Bit15	JP20 used for switchover to back door	JP20 is used for input of switchover between the front door and the back door.	0

F6-41 Program Control Selection 2			
Bit	Function	Description	Default
Bit0	Reserved	-	0
Bit1	Reserved	-	0
Bit2	Inspection to stop due to slow-down 1	During inspection running, if the slow-down 1 acts, the system decelerates to stop.	0
Bit3	Reserved	-	0
Bit4	Buzzer tweet during door open delay	The buzzer will tweet when the door open delay time set in Fb-14 is reached.	0
Bit5	Reserved	-	0
Bit6	Cancelling door open delay	Door open delay is cancelled when the door open delay button is pressed again.	0
Bit7	Reserved	-	0
Bit8	Elevator lock at door open	In the elevator lock state, the elevator keeps the door open at the elevator lock floor.	0
Bit9	Display available at elevator lock	In the elevator lock state, hall calls are displayed normally.	0
Bit10	Elevator lock in the attendant state	The elevator is locked properly in the attendant state.	0
Bit11	Blinking at arrival	The car display blinks when the elevator arrives at a floor. The blinking advance time is set in F6-47.	0
Bit12	Door re-open during door open delay	The door re-opens if the door open delay input is active during door close.	0
Bit13	Door re-open after car call of the present floor	The door re-opens if the car call of the present floor is valid during door close.	0
F6-42 Program Control Selection 3			
Bit	Function	Description	Default
Bit0	Reserved	-	0
Bit1	Cancelling door open/close command at delay after door open/close limit	If this function is enabled, the door open/close command is cancelled at the delay of 1s after door open/close limit.	0
Bit2	Not judging door lock state at door close output	On normal conditions, the system determines that the door is completely closed only when the door close limit signal is active and the door lock is applied. If this function is enabled, the system need not judge the door lock state.	0
Bit3	Door close command output during running	The door close command is output continuously during the elevator running.	0
Bit4	Returning to base floor for verification at first-time power-on	The elevator runs to the bottom floor for verification at power-on for the first time.	0
Bit5	Landing at nearest floor at elevator lock	If the elevator lock signal is active, the elevator clears all car calls and hall calls and lands at the nearest floor.	0

Function Code	Parameter Name	Setting Range	Default	Unit	Property
F6-43	Attendant function selection	0–65535	0	-	★

It is used to select the attendant-related elevator functions. "1" indicates that the function is enabled, and "0" indicates that the function is disabled.

The functions defined by the binary bits are described in the following table.

Table 7-9 Attendant-related functions indicated by bits of F6-43

F6-43 Attendant Function Selection			
Bit	Function	Description	Default
Bit0	Calls cancelled after entering attendant state	All car calls and hall calls are cancelled after the system enters the attendant state for the first time.	0
Bit1	Not responding to hall calls	The car blinks inside, prompting there is hall call, but the system does not respond.	0
Bit2	Attendant/Automatic state switchover	If this function is enabled, the setting of F5-00 (Attendant/Normal switchover time) is valid.	0
Bit3	Door close at jogging	The elevator door closes after the attendant presses the door close button manually.	0
Bit4	Automatic door close	It is the same as the normal state. After the door open holding time is reached, the door closes automatically.	0
Bit5	Buzzer tweeting at intervals in attendant state	When the hall call floor and the car call floor are different, the buzzer tweets 2.5s at intervals.	0
Bit6	Continuous buzzer tweeting in attendant state	When the hall call floor and the car call floor are different, the buzzer tweets continuously.	0
Bit7	Car call button blinking to prompt	When the hall call input is active, the car call button for the corresponding floor blinks to give a prompt.	0

Function Code	Parameter Name	Setting Range	Default	Unit	Property
F6-44	Fire emergency function selection	0–65535	16456	-	★

It is used to select the fire emergency functions. "1" indicates that the function is enabled, and "0" indicates that the function is disabled.

The functions defined by the binary bits are described in the following table.

Table 7-10 Fire emergency functions indicated by bits of F6-44

F6-44 Fire Emergency Function Selection			
Bit	Function	Description	Default
Bit0 to Bit2	Reserved	-	0
Bit3	Arrival gong output in inspection or fire emergency state	The arrival gong is output in the inspection or fire emergency state.	0
Bit4	Multiple car calls registered in fire emergency state	Multiple car calls can be registered in the fire emergency state. If this function is disabled, only one car call can be registered.	0
Bit5	Retentive at power failure in fire emergency state	In the fire emergency state, the current system and car state will be memorized at power failure and be resumed after the system is powered on again.	0
Bit6	Closing door by holding down the door close button	In the fire emergency state, the door close process can be completed only by holding down the door close button until the door close limit is reached. Otherwise, it will be switched over to door open automatically.	0
Bit7	Reserved	-	0
Bit8	Door close at car call registering	The elevator enters the door close process automatically if a car call is registered.	0
Bit9	Displaying hall calls in fire emergency state	Hall calls are displayed in the fire emergency state.	0
Bit10	Firefighter forced running	JP22 is used for firefighter forced running input. In the firefighter running state, when the JP22 input switch and the door close button are enabled simultaneously, the buzzer tweets and the system outputs the door close signal. If the door lock is not enabled within 10s, the system outputs the shorting door lock circuit contactor signal, and the elevator starts running (used together with SCB-A).	0
Bit11	Exiting fire emergency state for firefighter	The system can exit the fire emergency state only after the elevator arrives at the fire emergency floor.	0
Bit12	Not clearing car calls at reverse door open in firefighter running state	In the firefighter running state, the car calls that have been registered are not cleared at reverse door open.	0
Bit13	Reserved	-	0
Bit14	Opening door by holding down the door open button	In the fire emergency state, the door open process can be completed only by holding down the door open button until the door open limit is reached. Otherwise, it will be switched over to door close automatically.	0
Bit15	Automatic door open in fire emergency floor	The door opens automatically after the elevator arrives at the fire emergency floor.	0

Function Code	Parameter Name	Setting Range	Default	Unit	Property
F6-45	Emergency evacuation function selection	0–65535	0	-	★

It is used to select the emergency evacuation-related functions. "1" indicates that the function is enabled, and "0" indicates that the function is disabled.

The functions defined by the binary bits are described in the following table.

Table 7-11 Emergency evacuation functions indicated by bits of F6-45

F6-45 Emergency Evacuation Function Selection								
Bit	Function	Description					Default	
Bit0	Direction determine mode	0	Automatically calculating direction	1	Load direction determining (based on load cell data or half-load signal)	1	Direction of nearest landing floor	0
Bit1		0		0		0		0
Bit2	Stopping at evacuation parking floor	During evacuation running, the elevator arrives at the evacuation parking floor set in F6-49 (it must be a non-zero value and is a service floor). Otherwise, the elevator stops at the nearest floor.					0	
Bit3	Reserved	-					0	
Bit4	Compensation at startup	The non-load-cell startup is still valid in the process of evacuation running.					0	
Bit5 to Bit7	Reserved	-					0	
Bit8	Emergency running time protection	If the elevator does not arrive at the required floor after 50s emergency evacuation running time, Err33 is reported. In this case, the function of switching over shorting stator braking mode to controller drive based on the time setting cannot be implemented.					0	
Bit9	Reserved	-					0	
Bit10	Emergency buzzer output	The buzzer tweets at intervals in the emergency evacuation running state.					0	
Bit11	Reserved	-					0	
Bit12	Shorting stator braking mode switched over to controller drive	It enables the function of switching over shorting stator braking mode to controller drive.					0	
Bit13	Mode of shorting stator braking mode switched over to controller drive	0	Time setting If the time of the shorting stator braking mode exceeds 50s, the controller starts to drive the elevator.			0		
		1	Speed setting If the speed is still smaller than the value of F6-48 after 10s in the shorting stator braking mode, the controller starts to drive the elevator.					

F6-45 Emergency Evacuation Function Selection						
Bit	Function	Description			Default	
Bit14	Emergency evacuation exit mode	0	The system exits emergency evacuation when receiving the door open limit signal from the elevator that arrives at the target floor.			0
		1	The system exits emergency evacuation when receiving the door close limit signal from the elevator that arrives at the target floor.			
Bit15	Function selection of shorting stator braking mode	It enables the function. When this function is enabled, the setting of related function codes becomes effective.			0	

Function Code	Parameter Name	Setting Range	Default	Unit	Property
F6-46	VIP function selection	0–65535	0	-	★

It is used to select the elevator VIP function. "1" indicates that the function is enabled, and "0" indicates that the function is disabled.

The functions defined by the binary bits are described in the following table.

Table 7-12 VIP functions indicated by bits of F6-46

F6-46 VIP Function Selection					
Bit	Function	Description			Default
Bit0	VIP enabled by hall call (at VIP floor)	After this function is enabled, the system enters VIP running.			0
Bit1	VIP enabled by terminal	After the terminal for VIP hall call becomes ON, the system enters VIP running.			0
Bit2-Bit7	Reserved	-			0
Bit8	Number of VIP car calls limited	If this function is enabled, only one car call can be selected simultaneously in the VIP state.			0

Function Code	Parameter Name	Setting Range	Default	Unit	Property
F6-47	Blinking advance time	0.0–15.0	0	s	☆

It is used to set the blinking advance time when the elevator arrives the floor required by the car call.

Function Code	Parameter Name	Setting Range	Default	Unit	Property
F6-48	Emergency evacuation switching speed	0.010–0.630	0.010	m/s	★

It is used to set the switching speed at shorting stator braking mode switched over to controller drive via speed setting.

Function Code	Parameter Name	Setting Range	Default	Unit	Property
F6-49	Evacuation parking floor	0 to F6-01	0	-	★

It is used to set the evacuation parking floor when Bit2 (Stopping at evacuation parking floor) in F6-45 is enabled.

Group F7: Test Function Parameters

This group of parameters is specialized for elevator commissioning.

Follow the instructions for normal-speed commissioning:

1. Before the commissioning, ensure that the shaft is unobstructed and the related parameters have been set properly.
2. Run the elevator to the middle floor of the shaft at the inspection speed so as to prevent wrong running direction.
3. Perform single-floor command commissioning and then perform multi-floor command commissioning.
4. After the commissioning is complete, check that the parameters in this group are set properly.

Function Code	Parameter Name	Setting Range	Default	Unit	Property
F7-00	Car call floor registered	0 to F6-00	0	-	☆
F7-01	Up call floor registered	0 to F6-00	0	-	☆
F7-02	Down call floor registered	0 to F6-00	0	-	☆

These parameters are used to set the destination floors at elevator commissioning or repairing. They can be respectively used as the car call button, hall call up button and hall call down button. They remain valid after the commissioning command is input, and become invalid until they are set to 0 or the system suffers power failure.

Function Code	Parameter Name	Setting Range	Default	Unit	Property
F7-03	Random running times	0–60000	0	-	☆

It is used to set the random running times of the system.

The NICE3000^{new} has the random automatic running function. If the setting of F7-03 is greater than 60000, the system keeps implementing random automatic running until you set F7-03 to 0.

You can set the time interval between two times of random running in F7-08.

Function Code	Parameter Name	Setting Range	Default	Unit	Property
F7-04	Hall call enabled	0: Yes 1: No	0	-	☆

It is used to enable the hall call function.

- 0: Yes (hall call allowed)
- 1: No (hall call forbidden)

Function Code	Parameter Name	Setting Range	Default	Unit	Property
F7-05	Door open enabled	0: Yes 1: No	0	-	☆

It is used to enable the door open function.

- 0: Yes (door open allowed)
- 1: No (door open forbidden)

Note

Continuous running of the elevator without opening the door accelerates overheating of the controller module. Long-time use in such mode may cause overheat protection, and therefore, use the function with caution.

Function Code	Parameter Name	Setting Range	Default	Unit	Property
F7-06	Overload function	0: Disabled 1: Enabled	0	-	☆

It is used to enable the overload function.

Note

This function is used only in the heavy-load test. Once the test is complete, prohibit overload running immediately.

Function Code	Parameter Name	Setting Range	Default	Unit	Property
F7-07	Limit switch	0: Enabled 1: Disabled	0	-	☆

It is used to enable the limit switch function.

Note

The limit switch is disabled only in the test of the final limit switch. Use the function with caution.

Function Code	Parameter Name	Setting Range	Default	Unit	Property
F7-08	Time interval of random running	0-1000	0	s	☆

It is used to set the time interval between two times of random running.

Group F8: Enhanced Function Parameters

Function Code	Parameter Name	Setting Range	Default	Unit	Property
F8-00	Load for load cell auto-tuning	0-100	0	%	★

It is used to set the load for load cell auto-tuning.

To perform load cell auto-tuning, do as follows:

1. Ensure that F8-01 is set to 0 and F5-36 is set to 2 or 3 to make the system allow load cell auto tuning.
2. Stop the elevator at any floor, with the car in the no-load state. Set F8-00 to 0 and press .
3. Put N% load in the car. Then set F8-00 to N and press the ENTER key.

For example, if you put 500 kg load in the elevator with rated load of 1000 kg, set F8-00 to 50.

After the load-cell auto-tuning is completed, the corresponding no-load and full-load data will be recorded in F8-06 and F8-07. You can also manually input the data according to the actual situation.

Function Code	Parameter Name	Setting Range	Default	Unit	Property
F8-01	Pre-torque selection	0–2	0	-	★

It is used to set the pre-torque compensation mode at startup of the elevator.

The values are as follows:

- 0: Pre-torque invalid
Load cell auto-tuning is allowed.
- 1: Load cell pre-torque compensation
With a load cell, the system implements the pre-torque compensation function.
- 2: Automatic pre-torque compensation
The system automatically adjusts the compensated torque at startup without a load cell.

If F8-01 is set to 1, the system outputs the torque matching the load in advance to ensure the riding comfort at startup. The output torque is limited by F2-08 (Torque upper limit). When the load torque is greater than the set torque upper limit, the output torque of the system is the torque upper limit.

Function Code	Parameter Name	Setting Range	Default	Unit	Property
F8-02	Pre-torque offset	0.0–100.0	50.0	%	★

It is used to set the pre-torque offset. It is actually the balance coefficient of the elevator, indicating the percentage of the car load to the rated load when the counterweight and the car weight are balanced.

Function Code	Parameter Name	Setting Range	Default	Unit	Property
F8-03	Drive gain	0.00–2.00	0.60	-	★
F8-04	Brake gain	0.00–2.00	0.60	-	★

These two parameters are used to set the pre-torque gain when the elevator runs on the drive side or the brake side.

For details, see section 5.1.5.

Function Code	Parameter Name	Setting Range	Default	Unit	Property
F8-05	Current car load	0–1023	0	-	●

This parameter is readable and reflects the load situation in the car. The value is sampled by the NICE3000^{new} by using a load cell. This parameter is used to judge overload or full-load, or calculate the torque current for load cell pre-torque compensation.

Function Code	Parameter Name	Setting Range	Default	Unit	Property
F8-06	Car no-load load	0–1023	0	-	★
F8-07	Car full-load load	0–1023	100	-	★

These two parameters respectively specify the car no-load load and full-load load. They are AD sampling values.

Note

If F8-06 = F8-07, the full-load and overload become invalid.

Function Code	Parameter Name	Setting Range	Default	Unit	Property
F8-08	Anti-nuisance function	0, 1, 2, 4	0	-	☆

It is the criteria for judging whether nuisance exists.

The values are as follows:

- 0: Anti-nuisance function disabled
- 1: Nuisance judged by load cell

A load cell is required. The system judges whether nuisance exists by comparing the load cell data and the number of car calls.

- 2: Nuisance judged by light curtain

The system determines that nuisance exists when the light curtain does not act after the elevator stops at arrival for three consecutive times.

- 4: Nuisance judged by light-load signal

If the light-load signal is active, the system determines that nuisance exists when the number of car calls is greater than a certain value.

When the system determines that the elevator is in the nuisance state, it cancels all car calls. In this case, call calls need to be registered again.

Function Code	Parameter Name	Setting Range	Default	Unit	Property
F8-09	Emergency evacuation operation speed at power failure	0.000 to F3-11	0.050	m/s	★

It is used to set the speed for emergency evacuation operation at power failure.

Function Code	Parameter Name	Setting Range	Default	Unit	Property
F8-10	Emergency evacuation operation mode at power failure	0–2	0	-	★

It is used to set the emergency evacuation operation mode at power failure.

- 0: Motor not running
- 1: UPS
- 2: 48 V battery power supply

For details, see section 5.2.1.

Function Code	Parameter Name	Setting Range	Default	Unit	Property
F8-11	Brake apply delay	0.200–1.500	0.200	s	★

It is used to set the time from the moment when the system sends the brake apply command to the moment when the brake is completely applied. For details, see Figure 7-3.

Function Code	Parameter Name	Setting Range	Default	Unit	Property
F8-12	Fire emergency floor 2	0 to F6-00	0	-	★

It is used to set the second fire emergency floor. The switchover between fire emergency floor 1 and fire emergency floor 2 is implemented by means of input from the MCB. When this signal is input, the elevator enters the fire emergency state and returns to this floor.

Function Code	Parameter Name	Setting Range	Default	Unit	Property
F8-16	Start address of hall call auxiliary command	0–40	0	-	☆

It is used to set the start address of hall calls from the back door.

Address of a hall call from the back door = Address of a hall call from the front door at the same floor + F8-16

Function Code	Parameter Name	Setting Range	Default	Unit	Property
F8-17	Hall call address check	0–1	0	-	☆

If it is valid, the HCB no longer displays the current floor information of the car but displays the set address of itself, convenient for inspection in the case of wrong floor address setting.

Group F9: Time Parameters

Function Code	Parameter Name	Setting Range	Default	Unit	Property
F9-00	Idle time before returning to base floor	0–240	10	min	☆

It is used to set the idle time of the elevator before returning to the base floor.

When the idle time of the elevator exceeds the setting of this parameter, the elevator returns to the base floor.

If this parameter is set to 0, it becomes invalid.

Function Code	Parameter Name	Setting Range	Default	Unit	Property
F9-01	Time for fan and lamp to be turned off	0–240	2	min	☆

It is used to set the time that fan and lamp stays ON before being turned off automatically.

If there is no running command in the automatic running state, the system turns off the fan and lamp automatically after the time set in this parameter.

If this parameter is set to 0, it becomes invalid.

Function Code	Parameter Name	Setting Range	Default	Unit	Property
F9-02	Motor running time limit	0–45	45	s	★

It is used to set the running time limit of the motor.

In normal running state, if the continuous motor running time in the same direction between two adjacent floors exceeds the setting of this parameter but no leveling signal is received, the system will perform protection.

This parameter is mainly used for over-time protection in the case of steel rope slipping on the traction sheave.

If this parameter is set to a value smaller than 3s, it becomes invalid.

Function Code	Parameter Name	Setting Range	Default	Unit	Property
F9-03	Clock: year	2000–2100	Current year	YYYY	☆
F9-04	Clock: month	1–12	Current month	MM	☆
F9-05	Clock: day	1–31	Current day	DD	☆
F9-06	Clock: hour	0–23	Current hour	HH	☆
F9-07	Clock: minute	0–59	Current minute	MM	☆

These parameters are used to set the current date and time of the system.

Timekeeping is supported at power failure. You need to set the current system time correctly so that functions related to the time can be implemented.

Function Code	Parameter Name	Setting Range	Default	Unit	Property
F9-09	Accumulative running time	0–65535	0	h	●
F9-11	High byte of running times	0–9999	0	-	●
F9-12	Low byte of running times	0–9999	0	-	●

These parameters are used to view the actual accumulative running time and running times of the elevator.

Running times of the elevator = F9-11 x 10000 + F9-12.

Function Code	Parameter Name	Setting Range	Default	Unit	Property
F9-13	Maintenance notification period	0–99	0	day	★

It is the forced maintenance notification function. When this parameter is set to a non-zero value, this function is enabled, and the system starts to count the days. If there is no power-off operation during the counting and the counted days reach the value of this parameter, the elevator enters the parking state and the system reports Err08, notifying that the elevator must be maintained and cannot run. Maintenance personnel need to power off and maintain the elevator, and then the system clears the value to 0 and starts counting again.

If this parameter is set to 0, this function is disabled.

Group FA: Keypad Setting Parameters

Function Code	Parameter Name	Setting Range	Default	Unit	Property
FA-00	Keypad display selection	0–3	3	-	☆

The NICE3000^{new} system has three buttons and three 7-segment LEDs on the MCB. You can change the display content through the setting of this parameter.

- 0: Reversed display of physical floor
- 1: Positive display of physical floor
- 2: Reversed display of hall call floor
- 3: Positive display of hall call floor

Function Code	Parameter Name	Setting Range	Default	Unit	Property
FA-01	Display in running state	1–65535	65535	-	☆

It is used to set the running parameters displayed on the keypad when the elevator is in the running state.

A total of 16 running parameters can be displayed during running, each respectively corresponding to the 16 binary bits of FA-01. "1" indicates that the parameter is displayed, while "0" indicates that the parameter is not displayed. You can switch over the displayed parameter by pressing the shift button and set whether to display this parameter according to your own using habit.

The 16 binary bits correspond to the running parameters listed in the following table.

Table 7-13 Running parameters corresponding to 16 bits of FA-01

Bit	Parameter Name	Default	Bit	Parameter Name	Default
Bit0	Running speed	1	Bit8	Output terminal	1
Bit1	Set speed	1	Bit9	Current floor	1
Bit2	Bus voltage	1	Bit10	Current position	1
Bit3	Output voltage	1	Bit11	Car load	1
Bit4	Output current	1	Bit12	CTB input state	1
Bit5	Output frequency	1	Bit13	CTB output state	1

Bit	Parameter Name	Default	Bit	Parameter Name	Default
Bit6	Input terminal low bits	1	Bit14	System state	1
Bit7	Input terminal high bits	1	Bit15	Pre-toque current	1

Function Code	Parameter Name	Setting Range	Default	Unit	Property
FA-02	Display in stop state	1-65535	65535	-	☆

It is used to set the parameters displayed on the keypad when the elevator is in the stop state.

A total of 16 parameters can be displayed at stop. The use is the same as that of FA-01.

The 16 binary bits correspond to the stop parameters listed in the following table.

Table 7-14 Stop parameters corresponding to 16 bits of FA-02

Bit	Parameter Name	Default	Bit	Parameter Name	Default
Bit0	Set speed	1	Bit8	Slow-down distance at rated speed	1
Bit1	Bus voltage	1	Bit9	CTB input state	1
Bit2	Input terminal low bits	1	Bit10	CTB output state	1
Bit3	Input terminal high bits	1	Bit11	System state	1
Bit4	Output terminal	1	Bit12	Reserved	0
Bit5	Current floor	1	Bit13	Reserved	0
Bit6	Current position	1	Bit14	Reserved	0
Bit7	Car load	1	Bit15	Reserved	0

The running and stop parameters of the NICE3000^{new} system are the important references for engineers to perform commissioning on site. The parameters are described as follows:

- 1) Running speed: indicates the actual running speed of the elevator.
Its maximum value is F0-03 (Maximum running speed), in unit of m/s.
- 2) Set speed: indicates the set speed of the NICE3000^{new} system during elevator running. It is the running speed calculated by the system theoretically at which the elevator should run. Its unit is m/s.
- 3) Bus voltage: indicates the DC bus voltage of the NICE3000^{new} system, in unit of m/s.
- 4) Output voltage: indicates the effective value of the equivalent voltage of the PWM wave output by the NICE3000^{new} system, in unit of V.
- 5) Output current: indicates the effective value of the actual current when the NICE3000^{new} system drives the motor to turn, in unit of A.
- 6) Output frequency: indicates the actual frequency of the motor during running. It has a fixed corresponding relationship with the running speed. The unit is Hz.
- 7) Input terminal low bits: indicate the meaning of input terminals by bit. "1" indicates that the signal is active.

A total of 16 bits are defined as below:

Bit	Meaning	Bit	Meaning
Bit0	Reserved	Bit8	Inspection signal
Bit1	Up leveling signal	Bit9	Inspection up signal
Bit2	Down leveling signal	Bit10	Inspection down signal
Bit3	Door zone signal	Bit11	Fire emergency signal
Bit4	Safety circuit feedback 1	Bit12	Up limit signal
Bit5	Door lock circuit feedback 1	Bit13	Down limit signal
Bit6	RUN contactor feedback	Bit14	Overload signal
Bit7	Brake contactor feedback 1	Bit15	Full-load signal

- 8) Input terminal high bits: indicate the meaning of input terminals by bit. "1" indicates that the signal is active.

A total of 16 bits are defined as below:

Bit	Meaning	Bit	Meaning
Bit0	Up slow-down 1 signal	Bit8	Door machine 1 light curtain
Bit1	Down slow-down 1 signal	Bit9	Door machine 2 light curtain
Bit2	Up slow-down 2 signal	Bit10	Brake output feedback 2
Bit3	Down slow-down 2 signal	Bit11	UPS input
Bit4	Up slow-down 3 signal	Bit12	Elevator lock input
Bit5	Down slow-down 3 signal	Bit13	Safety circuit feedback 2
Bit6	Shorting door lock circuit contactor output feedback	Bit14	Synchronous motor self-locked feedback
Bit7	Motor overheat signal	Bit15	Door lock circuit feedback 2

- 9) Output terminal: indicates the meaning of output terminals by bit. "1" indicates that the signal is active.

A total of 16 bits are defined as below:

Bit	Meaning	Bit	Meaning
Bit0	Reserved	Bit8	Door machine 2 close
Bit1	RUN contactor output	Bit9	Contactor healthy
Bit2	Brake contactor output	Bit10	Fault state
Bit3	Shorting door lock circuit contactor output	Bit11	System in running state
Bit4	Fire emergency floor arrival signal	Bit12	Reserved
Bit5	Door machine 1 open	Bit13	Reserved
Bit6	Door machine 1 close	Bit14	Reserved
Bit7	Door machine 2 open	Bit15	Emergency leveling buzzer output

- 10) Current floor: indicates the information of the physical floor where the elevator is located. It is the same as the value of F4-01.
- 11) Current position: indicates the absolute distance from the current elevator car to the leveling flag of the first floor, in unit of m.
- 12) Car load: indicates the percentage of the car load to the rated load judged by the NICE3000^{new} system based on data from the sensor, in unit of %.
- 13) CTB input state: indicates the meaning of CTB inputs by bit. "1" indicates that the signal is active.

A total of 16 bits are defined as below:

Bit	Meaning	Bit	Meaning
Bit0	Light curtain 1	Bit8	Door open button
Bit1	Light curtain 2	Bit9	Door close button
Bit2	Door open limit 1	Bit10	Door open delay button
Bit3	Door open limit 2	Bit11	Direct travel ride signal
Bit4	Door close limit 1	Bit12	Attendant signal
Bit5	Door close limit 2	Bit13	Direction change signal
Bit6	Full-load signal	Bit14	Independent running signal
Bit7	Overload signal	Bit15	Firefighter operation signal

- 14) CTB output state: indicates the meaning of CTB outputs by bit. "1" indicates that the signal is active.

A total of 16 bits are defined as below:

Bit	Meaning	Bit	Meaning
Bit0	Door open output 1	Bit8	Door open button display
Bit1	Door close output 1	Bit9	Door close button display
Bit2	Door lock signal	Bit10	Door open delay button display
Bit3	Door open output 2	Bit11	Non-door zone stop
Bit4	Door close output 2	Bit12	Reserved
Bit5	Door lock signal	Bit13	Buzzer output
Bit6	Up arrival gong signal	Bit14	Reserved
Bit7	Down arrival gong signal	Bit15	Energy saving signal

- 15) System state: indicates the system state by bit. "1" indicates that the signal is active.

A total of 16 bits are defined as below:

Bit	Meaning	Bit	Meaning
Bit0	Light curtain state 1	Bit8	Car state: 1: Door open 2: Door open holding 3: Door close 4: Door close limit 5: Running
Bit1	Light curtain state 2	Bit9	
Bit2	Hall elevator lock (indicated on HCB)	Bit10	
Bit3	Hall fire emergency (indicated on HCB)	Bit11	
Bit4	Elevator state: 0: Inspection 1: Shaft auto-tuning 3: Return to base floor at fire emergency 4: Firefighter operation 6: Attendant operation 7: Automatic (normal)	Bit12	
Bit5		Bit13	Overload
Bit6		Bit14	Reserved
Bit7		Bit15	Reserved

- 16) Pre-torque current: indicates the percentage of the pre-torque current compensated by the NICE3000^{new} system at startup to the rated current, in unit of %.

Function Code	Parameter Name	Setting Range	Default	Unit	Property
FA-03	Current encoder angle	0.0–359.9	0.0	Degree (°)	●

It displays the real-time encoder angle. This parameter cannot be modified.

Function Code	Parameter Name	Setting Range	Default	Unit	Property
FA-05	Control board software	0–65535	0	-	●
FA-06	Drive board software	0–65535	0	-	●

These two parameters respectively display the program version number of the logic control board and the drive control board.

Function Code	Parameter Name	Setting Range	Default	Unit	Property
FA-07	Heatsink temperature	0–100	0	°C	●

It displays the current temperature of the heatsink.

Normally, the heatsink temperature is below 40°C. When the heatsink temperature is too high, the system lowers the carrier frequency automatically to reduce heat dissipation. When the heatsink temperature rises to a certain value, the system reports the module overheat fault and stops running.

Function Code	Parameter Name	Setting Range	Default	Unit	Property
FA-11	Pre-torque current	0.0–200.0	0	%	●

It displays the percentage of pre-torque current to the rated current (positive/negative display, indicating driving or braking).

Function Code	Parameter Name	Setting Range	Default	Unit	Property
FA-12	Logic information	0-65535	0	-	●

It displays the elevator status parameters.

The LEDs are arranged as 5, 4, 3, 2, 1 from left to right. LED 1 shows the state of door 1. LEDs 2 and 3 have no display. LEDs 4 and 5 together show the elevator state.

Figure 7-7 Elevator state display

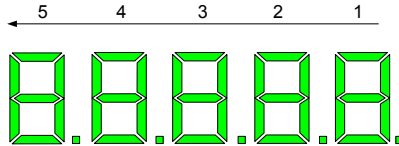

The LEDs are defined in the following table.

Table 7-15 LED display of the elevator state

LED 5		LED 4		LED 3	LED 2	LED 1	
Elevator State				No Display	No Display	Door 1 State	
00	Inspection state	8	Elevator lock	-	-	0	Waiting state
01	Shaft auto-tuning	09	Idle elevator parking			1	Door open state
02	Micro-leveling	10	Re-leveling at inspection speed			2	Door open limit
03	Returning to base floor at fire emergency	11	Emergency evacuation operation			3	Door close state
04	Firefighter operation	12	Motor auto-tuning			4	Door close limit
05	Fault state	13	Keypad control			-	-
06	Attendant operation	14	Base floor check			-	-
07	Automatic running	15	VIP state			-	-

Function Code	Parameter Name	Setting Range	Default	Unit	Property
FA-13	Curve information	0-65535	0	-	●

It displays the system running curve information. LEDs 5, 4 and 3 have no display, while LEDs 2 and 1 show the running curve information.

LED 5	LED 4	LED 3	LED 2		LED 1	
No Display	No Display	No Display	Curve Information			
-	-	-	00	Standby state	09	Deceleration start segment
			01	Zero-speed start segment	10	Linear deceleration segment
			02	Zero-speed holding segment	11	Deceleration end segment
			03	Reserved	12	Zero speed at stop
			04	Startup speed stage	13	Current stop phase
			05	Acceleration start segment	14	Reserved
			06	Linear acceleration segment	15	Stop data processing
			07	Acceleration end segment	16-20	Auto-tuning stage
			08	Stable-speed running segment	21	Emergency operation

Function Code	Parameter Name	Setting Range	Default	Unit	Property
FA-14	Set speed	0.000–4.000	0	m/s	●
FA-15	Feedback speed	0.000–4.000	0	m/s	●
FA-16	Bus voltage	0–999.9	0	V	●
FA-17	Present position	0.00–300.0	0	m	●
FA-18	Output current	0.0–999.9	0	A	●
FA-19	Output frequency	0.00–99.99	0	Hz	●
FA-20	Torque current	0.0–999.9	0	A	●
FA-21	Output voltage	0–999.9	0	V	●
FA-22	Output torque	0–100	0	%	●
FA-23	Output power	0.00–99.99	0	kW	●

These parameters display the current performance state of the system (the output torque and output power supports positive/negative display).

Function Code	Parameter Name	Setting Range	Default	Unit	Property
FA-24	Communication interference	0–65535	0	-	●

It displays the current communication quality of the system, as described in the following table.

Table 7-16 Communication quality display

LED 5		LED 4	LED 3		LED 2		LED 1	
SPI Communication Quality		No Display	CAN2 Communication Quality		Modbus Communication Quality		CAN1 Communication Quality	
0	Good	-	0	Good	0	Good	0	Good
↓	↑		↓	↑	↓	↑	↓	↑
9	Interrupted		9	Interrupted	9	Interrupted	9	Interrupted

0–9 indicates the communication quality. The greater the number is, the larger interference the communication suffers and the poorer the communication quality is.

Function Code	Parameter Name	Setting Range	Default	Unit	Property
FA-26	Input state 1	0–65535	0	-	●
FA-27	Input state 2	0–65535	0	-	●
FA-28	Input state 3	0–65535	0	-	●
FA-30	Input state 5	0–65535	0	-	●
FA-31	Output state 1	0–65535	0	-	●
FA-32	Output state 2	0–65535	0	-	●
FA-33	Car input state	0–65535	0	-	●
FA-34	Car output state	0–65535	0	-	●
FA-35	Hall state	0–65535	0	-	●
FA-36	System state 1	0–65535	0	-	●
FA-37	System state 2	0–65535	0	-	●

The following figure shows an example of the displayed input states.

Figure 7-8 Example of input state display

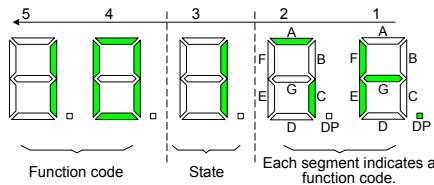

As shown in the preceding figure, the LEDs from right to left are numbered 1, 2, 3, 4, and 5. For FA-26 to FA-37, LEDs 5 and 4 show the function No.; LED 3 shows whether the function is valid (1) or invalid (0); the 16 segments of LEDs 1 and 2 show the states of the 16 functions in this parameter. According to the figure, LEDs 5, 4, and 3 show that function 10 (Inspection down) is 1 (Valid); LEDs 1 and 2 show that besides function 10, functions 4 (Safety circuit feedback), 5 (Door lock circuit feedback), 6 (RUN contactor feedback), 7 (Brake contactor feedback), and 8 (Inspection signal) are valid.

FA-26 Input state 1				FA-28 Input state 3			
No.	Function	No.	Function	No.	Function	No.	Function
0	Reserved	8	Inspection signal	64	Reserved	72	Fire emergency floor switchover
1	Up leveling signal	9	Inspection up	65	Door 1 safety edge signal	73	Reserved
2	Down leveling signal	10	Inspection down	66	Door 2 safety edge signal	74	Reserved
3	Door zone signal	11	Fire emergency signal	67	Motor overheat signal	75	Reserved
4	Safety circuit feedback	12	Up limit signal	68	Earthquake signal	76	Reserved
5	Door lock circuit feedback	13	Down limit signal	69	Back door forbidden	77	Reserved
6	RUN contactor feedback	14	Overload signal	70	Light-load	78	Reserved
7	Brake contactor feedback	15	Full-load signal	71	Half-load	79	Reserved
FA-27 Input state 2				FA-30 Input state 5			
No.	Function	No.	Function	No.	Function	No.	Function
16	Up slow-down 1 signal	24	Door machine 1 light curtain	0	Reserved	8	Reserved
17	Down slow-down 1 signal	25	Door machine 2 light curtain	1	Reserved	9	Reserved
18	Up slow-down 2 signal	26	Brake contactor feedback 2	2	Reserved	10	Reserved
19	Down slow-down 2 signal	27	UPS input	3	Reserved	11	Reserved
20	Up slow-down 3 signal	28	Elevator lock input	4	Higher-voltage safety circuit signal	12	Reserved
21	Down slow-down 3 signal	29	Safety circuit 2 signal	5	Higher-voltage door lock circuit signal	13	Reserved
22	Shorting door lock circuit contactor feedback	30	Shorting motor stator contactor feedback	6	Reserved	14	Reserved
23	Firefighter running signal	31	Door lock circuit 2 feedback	7	Reserved	15	Reserved

FA-31 Output state 1				FA-32 Output state 2			
No.	Function	No.	Function	No.	Function	No.	Function
0	Reserved	8	Door 2 close	16	Higher-voltage startup of brake	24	Reserved
1	RUN contactor output	9	Brake and RUN contactors healthy	17	Elevator running in up direction	25	Reserved
2	Brake contactor output	10	Fault state above level 3	18	Lamp/Fan output	26	Reserved
3	Shorting door lock circuit contactor output	11	Running state	19	Medical sterilization	27	Reserved
4	Fire emergency floor arrival	12	Shorting motor stator contactor output	20	Non-door zone stop	28	Reserved
5	Door 1 open	13	Power failure emergency output	21	Electric lock output	29	Reserved
6	Door 1 close	14	System healthy	22	Non-service state	30	Reserved
7	Door 2 open	15	Emergency leveling tweet	23	Reserved	31	Reserved
FA-33 Car input state				FA-34 Car output state			
No.	Function	No.	Function	No.	Function	No.	Function
0	Reserved	8	Overload input	0	Reserved	8	Down arrival gong
1	Door 1 light curtain	9	Light-load input	1	Door 1 open	9	Reserved
2	Door 2 light curtain	10	Reserved	2	Door 1 close	10	Reserved
3	Door 1 open limit	11	Reserved	3	Forced door close 1	11	Reserved
4	Door 2 open limit	12	Reserved	4	Door 2 open	12	Reserved
5	Door 1 close limit	13	Reserved	5	Door 2 close	13	Reserved
6	Door 2 close limit	14	Reserved	6	Forced door close 2	14	Reserved
7	Full-load input	15	Reserved	7	Up arrival gong	15	Reserved

FA-35 Hall state							
No.	Function	No.	Function	No.	Function	No.	Function
0	Reserved	4	VIP signal	8	Reserved	12	Reserved
1	Elevator lock signal	5	Security signal	9	Reserved	13	Reserved
2	Fire emergency signal	6	Door close button input	10	Reserved	14	Reserved
3	Current floor forbidden	7	Reserved	11	Reserved	15	Reserved
FA-36 System state 1				FA-37 System state 2			
No.	Function	No.	Function	No.	Function	No.	Function
0	Door open 1 button	8	Door open 2 button	0	Up direction display	8	Reserved
1	Door close 1 button	9	Door close 2 button	1	Down direction display	9	Reserved
2	Door open delay 1	10	Door open 2	2	Running state	10	Reserved
3	Direct travel ride switch	11	Reserved	3	System full-load	11	Reserved
4	Attendant switch	12	Reserved	4	System overload	12	Reserved
5	Direction change switch	13	Reserved	5	System half-load	13	Reserved
6	Independent running switch	14	Reserved	6	System light-load	14	Reserved
7	Fire emergency 2 switch	15	Reserved	7	Reserved	15	Reserved

Function Code	Parameter Name	Setting Range	Default	Unit	Property
FA-46	Hall call communication state 1	0-65535	0	-	●
FA-47	Hall call communication state 2	0-65535	0	-	●
FA-48	Hall call communication state 3	0-65535	0	-	●

These parameters display the communication state between HCBs of all floors and the MCB.

FA-46, FA-47, and FA-48 respectively indicate the communication state of floors 1 to 16, 17 to 32, and 33 to 40. As shown in Figure 7-4, LEDs 5 and 4 show the floor address; LED 3 show whether the communication for this floor address is normal ("1" is displayed) or interrupted ("0" is displayed). The communication quality can be viewed from LEDs 1 and 2: The 16 segments show the communication state of 16 floor addresses; ON indicates that the communication is normal, and OFF indicates that the communication is interrupted.

Group Fb: Door Function Parameter

Function Code	Parameter Name	Setting Range	Default	Unit	Property
Fb-00	Number of door machine (s)	1-2	1	-	★

It is used to set the number of door machine(s).

Set this parameter based on actual conditions.

Function Code	Parameter Name	Setting Range	Default	Unit	Property
Fb-01	CTB software	00-999	0	-	●

It displays the software of the CTB connected to the controller.

Function Code	Parameter Name	Setting Range	Default	Unit	Property
Fb-02	Service floors 1 of door machine 1	0-65535	65535	-	☆
Fb-03	Service floors 2 of door machine 1	0-65535	65535	-	☆
Fb-18	Service floors 3 of door machine 1	0-65535	65535	-	☆
Fb-04	Service floors 1 of door machine 2	0-65535	65535	-	☆
Fb-05	Service floors 2 of door machine 2	0-65535	65535	-	☆
Fb-19	Service floors 3 of door machine 2	0-65535	65535	-	☆

These parameters are used to set the service floors of door machine 1 and door machine 2.

Service floors 1 correspond to floors 1-16; service floors 2 correspond to floors 17-32; service floors 3 correspond to floors 33-48. The setting method is the same as that for F6-05.

Function Code	Parameter Name	Setting Range	Default	Unit	Property
Fb-06	Door open protection time	5-99	10	s	☆

It is used to set the door open protection time.

After outputting the door open command, if the system does not receive the door open limit signal after the time set in this parameter, the system re-opens the door. When the door open/close times reach the value set in Fb-09, the system reports fault Err48.

Function Code	Parameter Name	Setting Range	Default	Unit	Property
Fb-07	Arrival gong output delay	0-1000	0	ms	☆

When the value of this parameter is larger than 10 and the car display is switched over to the destination floor, the system outputs the arrival gong after the time set in this parameter. If the value is smaller than 10, the system outputs the arrival gong at stop.

Function Code	Parameter Name	Setting Range	Default	Unit	Property
Fb-08	Door close protection time	5–99	15	s	☆

It is used to set the door close protection time.

After outputting the door close command, if the system does not receive the door close limit signal after the time set in this parameter, the system re-closes the door. When the door open/close times reach the value set in Fb-09, the system reports fault Err49.

Function Code	Parameter Name	Setting Range	Default	Unit	Property
Fb-09	Door re-open times	0–20	0	-	☆

It is used to set the door re-open/re-close times allowed when door open/close is abnormal.

Note

If this parameter is set to 0, it indicates that door re-open is not supported; in this case, the elevator keeps opening/closing the door if it does not receive the door open/close limit signal.

Function Code	Parameter Name	Setting Range	Default	Unit	Property
Fb-10	Door state of standby elevator	0–2	0	-	☆

It is used to set the door state when the elevator is in stop and standby state.

The values are as follows:

- 0: Closing the door as normal at base floor
- 1: Waiting with door open at base floor
- 2: Waiting with door open at each floor

Function Code	Parameter Name	Setting Range	Default	Unit	Property
Fb-11	Door open holding time for hall call	1–1000	5	s	☆

It is used to set the door open holding time when there is a hall call. The elevator closes the door immediately after receiving a door close command.

Function Code	Parameter Name	Setting Range	Default	Unit	Property
Fb-12	Door open holding time for car call	1–1000	3	s	☆

It is used to set the door open holding time when there is a car call. The elevator closes the door immediately after receiving a door close command.

Function Code	Parameter Name	Setting Range	Default	Unit	Property
Fb-13	Door open holding time at base floor	1–1000	10	s	☆

It is used to set the door open holding time after the elevator arrives at the base floor. The elevator closes the door immediately after receiving a door close command.

Function Code	Parameter Name	Setting Range	Default	Unit	Property
Fb-14	Door open delay	10–1000	30	s	☆

It is used to set the door open holding time when there is door open delay input. The elevator closes the door immediately after receiving a door close command.

Function Code	Parameter Name	Setting Range	Default	Unit	Property
Fb-15	Special door open holding time	10–1000	30	s	☆

It is used to set the door open holding time when there is a disability call.

Function Code	Parameter Name	Setting Range	Default	Unit	Property
Fb-16	Manual door open holding time	1–60	5	s	☆

It is used to set the door open limit delay in the case of manual door. This parameter is valid when the manual door function is used.

Function Code	Parameter Name	Setting Range	Default	Unit	Property
Fb-17	Holding time for forced door close	5–180	120	s	☆

It is used to set the holding time before forced door close is implemented.

If the forced door close function is enabled, the system enters the forced door close state and sends a forced door close signal when there is no door close signal after the time set in this parameter is reached.

Group FC: Protection Function Parameters

Function Code	Parameter Name	Setting Range	Default	Unit	Property
FC-00	Program control for protection function	0–65535	0	-	★

It is used to set program control related to protection functions. "1" indicates that the function is enabled, and "0" indicates that the function is disabled.

FC-00 Program control for protection function			
Bit	Function	Description	Default
Bit0	Short-circuit to ground detection at power-on	Whether the motor is short-circuited to ground is detected at power-on. If the motor is short-circuited to ground, the controller blocks the output immediately, and reports the fault.	0
Bit1	Reserved	-	0
Bit2	Decelerating to stop at valid light curtain	During normal-speed running, the elevator decelerates to stop immediately after the light curtain acts, and then runs to the registered destination floor after the light curtain restores. This function is mainly used in the case of manual door.	0

FC-00 Program control for protection function			
Bit	Function	Description	Default
Bit9	Mode without door open/close limit	In this mode, the door open/close limit signal is not required, and the system automatically judges door open/close limit. The system determines that door open limit is implemented 3s after the door open command is output and door close limit is implemented 3s after the door close command is output.	0

Function Code	Parameter Name	Setting Range	Default	Unit	Property
FC-01	Program control 2 for protection function	0–65535	65	-	★

It is used to set program control related to protection functions. "1" indicates that the function is enabled, and "0" indicates that the function is disabled.

FC-01 Program control 2 for protection function			
Bit	Function	Description	Default
Bit0	Overload protection	It sets whether to implement overload protection.	1
Bit1	Canceling protection at output phase loss	It sets whether to implement protection at output phase loss.	0
Bit4	Light curtain judgment at door close limit	At door close limit, the door re-opens if the light curtain is valid.	0
Bit5	Canceling SPI communication judgment	It sets whether to implement wire-breaking detection on SPI communication between the MCB and the drive board.	0
Bit6	Reserved	-	0
Bit8	Reserved	-	0
Bit14	Canceling protection at input phase loss	It sets whether to implement protection at input phase loss.	0

Function Code	Parameter Name	Setting Range	Default	Unit	Property
FC-02	Overload protection coefficient	0.50–10.00	1.00	-	★

After detecting that the output current exceeds (FC-02 x Rated motor current) and the duration lasts the time specified in the inverse time lag curve, the system outputs fault Err11 indicating motor overload.

Function Code	Parameter Name	Setting Range	Default	Unit	Property
FC-03	Overload pre-warning coefficient	50%–100%	80%	-	★

After detecting that the output current exceeds (FC-03 x Rated motor current) and the duration lasts the time specified in the inverse time lag curve, the system outputs a pre-warning signal.

Function Code	Parameter Name	Setting Range	Default	Unit	Property
FC-04	Opposite door selection	0–3	0	-	★

It is used to set opposite door-related control function.

The values are as follows:

- 0: Simultaneous control
- 1: Hall call independent, car call simultaneous
- 2: Hall call independent, car call manual control
- 3: Hall call independent, car call independent

For details on the use of the opposite door, see section 5.2.3.

Function Code	Parameter Name	Setting Range	Default	Unit	Property
FC-06	Designated fault	0–99	0	-	☆

It is used to designate the fault to be monitored.

The designated fault code is saved in parameters of FC-07 to FC-19, and will not be overwritten.

Function Code	Parameter Name	Setting Range	Default	Unit	Property
FC-07	Designated fault code	0–9999	0	-	●
FC-08	Designated fault subcode	0–65535	0	-	●
FC-09	Designated fault month and day	0–1231	0	MM.DD	●
FC-10	Designated fault hour and minute	0–23.59	0	HH.MM	●
FC-11	Logic information of designated fault	0–65535	0	-	●
FC-12	Curve information of designated fault	0–65535	0	-	●
FC-13	Set speed upon designated fault	0.000–4.000	0	m/s	●
FC-14	Feedback speed upon designated fault	0.000–4.000	0	m/s	●
FC-15	Bus voltage upon designated fault	0.0–999.9	0	V	●
FC-16	Current position upon designated fault	0.0–300.0	0	m	●
FC-17	Output current upon designated fault	0.0–999.9	0	A	●
FC-18	Output frequency upon designated fault	0.00–99.99	0	Hz	●
FC-19	Torque current upon designated fault	0.0–999.9	0	A	●

Function Code	Parameter Name	Setting Range	Default	Unit	Property
FC-20	1st fault code	0-9999	0	-	●
FC-21	1st fault subcode	0-65535	0	-	●
FC-22	1st fault month and day	0-1231	0	MM.DD	●
FC-23	1st fault hour and minute	0-23.59	0	HH.MM	●
FC-24	2nd fault code	0-9999	0	-	●
FC-25	2nd fault subcode	0-65535	0	-	●
FC-26	2nd fault month and day	0-1231	0	MM.DD	●
FC-27	2nd fault hour and minute	0-23.59	0	HH.MM	●
...					
FC-56	10th fault code	0-9999	0	-	●
FC-57	10th fault subcode	0-65535	0	-	●
FC-58	10th fault month and day	0-1231	0	MM.DD	●
FC-59	10th fault hour and minute	0-23.59	0	HH.MM	●

These parameters record the latest 10 faults of the elevator.

The fault code is a 4-digit number. The two high digits indicate the floor where the car is located when the fault occurs, and the two low digits indicate the fault code. For example, the 1st fault code is 0835, indicating that when the 1st fault (fault Err35) occurs, the car is near floor 8.

The fault subcode is used to locate the causes of the fault. The specific fault time is recorded in month, day, hour and minute.

Function Code	Parameter Name	Setting Range	Default	Unit	Property
FC-60	Latest fault code	0-9999	0	-	●
FC-61	Latest fault subcode	0-65535	0	-	●
FC-62	Latest fault month and day	0-1231	0	MM.DD	●
FC-63	Latest fault hour and minute	0-23.59	0	HH.MM	●
FC-64	Logic information of latest fault	0-65535	0	-	●
FC-65	Curve information of latest fault	0-65535	0	-	●
FC-66	Set speed upon latest fault	0.000-4.000	0	m/s	●
FC-67	Feedback speed upon latest fault	0.000-4.000	0	m/s	●
FC-68	Bus voltage upon latest fault	0.0-999.9	0	V	●
FC-69	Current position upon latest fault	0.0-300.0	0	m	●
FC-70	Output current upon latest fault	0-999.9	0	A	●
FC-71	Output frequency upon latest fault	0.00-99.99	0	Hz	●
FC-72	Torque current upon latest fault	0.0-999.9	0	A	●

Group Fd: Communication Parameters

Function Code	Parameter Name	Setting Range	Default	Unit	Property
Fd-00	Baud rate	0: 9600 1: 38400	0	bit/s	★
Fd-02	Local address	0–127 0: Broadcast address	1	-	★
Fd-03	Communication response delay	0–20	10	ms	★
Fd-04	Communication timeout	0.0–60.0 0: Invalid	0.0	s	★

These RS232 serial port communication parameters are used for communication with the monitor software in the host computer.

- Fd-00 specifies the baud rate for serial communication. Fd-02 specifies the current address of the controller. The setting of these two parameters must be consistent with the setting of the serial port parameters on the host computer.
- Fd-03 specifies the delay for the controller to send data by means of the serial port.
- Fd-04 specifies the communication timeout time of the serial port. Transmission of each frame must be completed within the time set in Fd-04; otherwise, a communication fault occurs.

Function Code	Parameter Name	Setting Range	Default	Unit	Property
Fd-05	Re-leveling stop delay	0.00–2.00	0.00	s	★

It is used to set the stop delay at re-leveling. After receiving the leveling signal during re-leveling, the elevator stops after the delay set in this parameter.

Function Code	Parameter Name	Setting Range	Default	Unit	Property
Fd-07	HCB:JP1 input	0: Reserved NO/NC input: 1/33: Elevator lock signal 2/34: Fire emergency signal 3/35: Current floor forbidden 4/36: VIP floor signal	1	-	★
Fd-08	HCB:JP2 input	5/37: Security floor signal 6/38: Door close button signal 7/39: Second fire emergency floor signal	2	-	★

These parameters are used to set the functions of pins 2 and 3 of JP1 and JP2 on the HCB. The setting is effective to the HCBs for all floors.

Function Code	Parameter Name	Setting Range	Default	Unit	Property
Fd-09	HCB:JP1 output	0: Invalid 1: Up arrival indicator 2: Down arrival indicator 3: Fault output	1	-	★
Fd-10	HCB:JP2 output	4: Non-door zone stop output 5: Non-service state output 6: Door close button indicator output	2	-	★

These parameters are used to set the functions of pins 1 and 4 of JP1 and JP2 on the HCB. The setting is effective to the HCBs for all floors.

Note

The output load capacity of the HCB is limited, with the output voltage of 24 V and the load power not larger than 1 W.

Function Code	Parameter Name	Setting Range	Default	Unit	Property
Fd-11	HCB-B:JP1 input	0: Reserved	0	-	★
Fd-12	HCB-B:JP2 input	NO/NC input: 1/33: Light-load signal	0	-	★
Fd-13	HCB-B:JP3 input	2/34: Half-load signal 3/35: Door 2 selection	0	-	★
Fd-14	HCB-B:JP4 input	4/36: Door 2 restricted (back door forbidden)	0	-	★
Fd-15	HCB-B:JP5 input	5/37: Door 1 safety edge 6/38: Door 2 safety edge	0	-	★
Fd-16	HCB-B:JP6 input	7/39: Single/Double door selection	0	-	★

These parameters are used to set the functions of pins 2 and 3 of JP1 to JP6 on the HCB-B no-display parallel-serial conversion board. The setting is effective to all HCB-Bs connected to the system.

Function Code	Parameter Name	Setting Range	Default	Unit	Property
Fd-17	HCB-B:A1 output	0: Reserved	0	-	★
Fd-18	HCB-B:A2 output	1: Fault output	0	-	★
Fd-19	HCB-B:B1 output	2: Non-door zone stop output	0	-	★
Fd-20	HCB-B:B2 output	3: Non-service state output	0	-	★
Fd-21	HCB-B:C1 output	4: Fire emergency output	0	-	★
Fd-22	HCB-B:C2 output	5: Power failure emergency output	0	-	★
Fd-23	HCB-B:C3 output	6: Door lock valid	0	-	★
Fd-24	HCB-B:C4 output	7: Night output signal	0	-	★
Fd-25	HCB-B:C5 output		0	-	★
Fd-26	HCB-B:C6 output		0	-	★

These parameters are used to set the functions of four relay outputs and six open-collector outputs on the HCB-B no-display parallel-serial conversion board. The setting is effective to all HCB-Bs connected to the system.

Group FE: Elevator Function Parameters

Function Code	Parameter Name	Setting Range	Default	Unit	Property
FE-00	Collective selective mode	0–2	0	-	★

It is used to set the collective selective mode of the system.

The values are as follows:

- 0: Full collective selective
 The elevator responds to both up and down hall calls.
- 1: Down collective selective
 The elevator responds to down hall calls but does not respond to up hall calls.
- 2: Up collective selective
 The elevator responds to hall up calls but does not respond to hall down calls.

Function Code	Parameter Name	Setting Range		Default	Unit	Property
FE-01	Floor 1 display	00: Display "0"	22: Display "23"	1901	-	☆
FE-02	Floor 2 display	01: Display "1"	23: Display "C"	1902	-	☆
FE-03	Floor 3 display	02: Display "2"	24: Display "D"	1903	-	☆
FE-04	Floor 4 display	03: Display "3"	25: Display "E"	1904	-	☆
FE-05	Floor 5 display	04: Display "4"	26: Display "F"	1905	-	☆
FE-06	Floor 6 display	05: Display "5"	27: Display "I"	1906	-	☆
FE-07	Floor 7 display	06: Display "6"	28: Display "J"	1907	-	☆
FE-08	Floor 8 display	07: Display "7"	29: Display "K"	1908	-	☆
FE-09	Floor 9 display	08: Display "8"	30: Display "N"	1909	-	☆
FE-10	Floor 10 display	09: Display "9"	31: Display "O"	0100	-	☆
Floor 11 to floor 30 display		10: Display "A"	32: Display "Q"	...		
FE-31	Floor 31 display	11: Display "B"	33: Display "S"	0301	-	☆
FE-35	Floor 32 display	12: Display "G"	34: Display "T"	0302	-	☆
FE-36	Floor 33 display	13: Display "H"	35: Display "U"	0303	-	☆
FE-37	Floor 34 display	14: Display "L"	36: Display "V"	0304	-	☆
FE-38	Floor 35 display	15: Display "M"	37: Display "W"	0305	-	☆
FE-39	Floor 36 display	16: Display "P"	38: Display "X"	0306	-	☆
FE-40	Floor 37 display	17: Display "R"	39: Display "Y"	0307	-	☆
FE-41	Floor 38 display	18: Display "-"	40: Display "Z"	0308	-	☆
FE-42	Floor 39 display	19: No display	41: Display "15"	0309	-	☆
FE-43	Floor 40 display	20: Display "12"	42: Display "17"	0400	-	☆
		21: Display "13"	43: Display "19"			

These parameters are used to set the display of each floor. The setting range is 0000–9999, where the two high digits indicate the display code of the ten's digit, and the two low digits indicate the display code of the unit's digit.

Function Code	Parameter Name	Setting Range	Default	Unit	Property
FE-52	Highest digit selection 1	0–4099	0	-	☆
FE-53	Highest digit selection 2		0	-	☆
FE-54	Highest digit selection 3		0	-	☆
FE-55	Highest digit selection 4		0	-	☆
FE-56	Highest digit selection 5		0	-	☆

These parameters are used to set special floor display.

When the 2-digit display cannot meet the requirement, you can add the third-digit display by setting these parameters. In the values of these parameters, the two high digits indicate the floor address that requires special display, and the two low digits indicate the display content.

For example, if floor 18 needs to be displayed as "17A", set FE-18 to 0710 (display "7A"), and then set the highest digit display, that is, FE-52 to 1801 (indicating that the highest digit display of floor address 18 is "1").

Function Code	Parameter Name	Setting Range	Default	Unit	Property
FE-32	Elevator function selection 1	0–65535	34816	-	☆

It is used to set the elevator functions. "1" indicates that the function is enabled, and "0" indicates that the function is disabled.

FE-32 Elevator function selection 1			
Bit	Function	Description	Default
Bit0	Reserved	-	0
Bit1	Reserved	-	0
Bit2	Re-leveling function	The elevator performs re-leveling at a low speed with door open. An external shorting door lock circuit contactor needs to be used together.	0
Bit3	Door pre-open function	During normal stop, when the elevator speed is smaller than a certain value and the door zone signal is active, the system shorts the door lock by means of the shorting door lock circuit contactor and outputs the door open signal, implementing door pre-open. This improves the elevator use efficiency.	0
Bit4	Stuck hall call cancellation	The system automatically identifies the state of the hall call buttons. If the state is abnormal, the system cancels the stuck hall call.	0
Bit5	Night security floor function	From 10:00 p.m to 6:00 a.m., the elevator runs to the security floor first every time, stops and opens the door, and then runs to the destination floor.	0

FE-32 Elevator function selection 1			
Bit	Function	Description	Default
Bit6	Down collective selective peak service	The peak service at down collective selective is used.	0
Bit7	Parallel/Group control peak service	The peak service is used.	0
Bit8	Time-based service floor function	For details, see the description of related parameters in group F6.	0
Bit9	VIP function	The VIP function is used.	0
Bit10	Reserved	-	0
Bit11	Car call deletion	A call can be deleted by pressing the button twice consecutively.	1
Bit12	Hall call deletion		0
Bit13 to Bit15	Reserved	-	0

Function Code	Parameter Name	Setting Range	Default	Unit	Property
FE-33	Elevator function selection 2	0-65535	36	-	☆

It is used to set the elevator functions. "1" indicates that the function is enabled, and "0" indicates that the function is disabled.

FE-33 Elevator Function Selection 2			
Bit	Function	Description	Default
Bit0	Reserved	-	0
Bit1	Door open holding at open limit	The system still outputs the door open command upon door open limit.	0
Bit2	Door close command not output upon door close limit	The system stops outputting the door close command upon door close limit.	1
Bit3	Reserved	-	0
Bit4	Auto reset for RUN and brake contactor stuck	If the feedback of the RUN and brake contactors is abnormal, faults Err36 and Err37 are reported, and you need to manually reset the system. With this function, the system resets automatically after the fault symptom disappears. A maximum of three auto reset times are supported.	0
Bit5	Slow-down switch stuck detection	The system detects the state of slow-down switches. Once detecting that a slow-down switch is stuck, the system instructs the elevator to slow down immediately and reports a corresponding fault.	1
Bit6	Reserved	-	0

FE-33 Elevator Function Selection 2			
Bit	Function	Description	Default
Bit7	Forced door close	If the door still does not close within the time set in Fb-17 in automatic state, the system outputs the forced door close signal; at this moment, the light curtain becomes invalid and the buzzer tweets.	0
Bit8	NO/NC output selection of shorting motor stator contactor	Bit8 = 0: NC output contactor Bit8 = 1: NO output contactor	0
Bit9	Immediate stop upon re-leveling	The elevator decelerates to stop immediately after receiving a single leveling signal during re-leveling. By default, when receiving a leveling signal, the elevator stops after the re-leveling stop delay set in Fd-05.	0
Bit10 to Bit12	Reserved	-	0
Bit13	High-speed elevator protection function	A maximum allowable speed is set when the car is in the slow-down switch position. When the elevator exceeds the speed at the position, the system outputs a protection signal.	0
Bit14	Reserved	-	0
Bit15	Opposite door independent control	For details, see section 5.2.3.	0

Group Fr: Leveling Adjustment Parameters

Function Code	Parameter Name	Setting Range	Default	Unit	Property
Fr-00	Leveling adjustment function	0: Disabled 1: Enabled	0	-	★

This parameter is used to enable the leveling adjustment function.

Function Code	Parameter Name	Setting Range	Default	Unit	Property	
Fr-01	Leveling adjustment record 1	00000–60060	30030	mm	★	
Fr-02	Leveling adjustment record 2		30030	mm	★	
...			...			
Fr-20	Leveling adjustment record 20		30030	mm	★	

These parameters are used to record the leveling adjustment values. Each parameter records the adjustment information of two floors, and therefore, the adjustment information of 40 floors can be recorded totally.

The method of viewing the record is shown in the following figure.

Figure 7-9 Viewing the leveling adjustment record

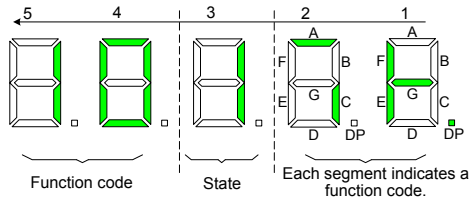

As shown in the preceding figure, the left two LEDs and the right two LEDs respectively show the adjustment bases of floor 1 and floor 2. If the value is larger than 30, it is upward leveling adjustment; if the value is smaller than 30, it is downward leveling adjustment. The default value "30" indicates that there is no leveling adjustment. The maximum adjustment range is ±30 mm.

The leveling adjustment method is as follows:

1. Ensure that shaft auto-tuning is completed successfully, and the elevator runs properly at normal speed.
2. Set Fr-00 to 1 to enable the car leveling adjustment function. Then, the elevator shields hall calls, automatically runs to the top floor, and keeps the door open after arrival. If the elevator is at the top floor, it directly keeps the door open.
3. Go into the car, press the top floor button, and the leveling position is changed 1 mm upward; press the bottom floor button, and the leveling position is changed 1 mm downward. The value is displayed in the car.

Positive value: up arrow + value, negative value: down arrow + value, adjustment range: ±30 mm

4. After completing adjustment for the current floor, press the top floor button and bottom floor button in the car at the same time to save the adjustment result. The car display restores to the normal state. If the leveling position of the current floor need not be adjusted, press the top floor button and bottom floor button in the car at the same time to exit the leveling adjustment state. Then, car calls can be registered.
5. Press the door close button, and press the button for the next floor. The elevator runs to the next floor and keeps the door open after arrival. Then, you can perform leveling adjustment.
6. After completing adjustment for all floors, set Fr-00 to 0 to disable the leveling adjustment function. Otherwise, the elevator cannot be used.

Pay attention to the following precautions during the operation:

1. Each time shaft auto-tuning is performed, all leveling adjustment parameters can be cleared or reserved.
 - a. If you set F1-11 to 3 on the operation panel or F7 to 1 on the keypad, all leveling adjustment parameters are reserved.
 - b. If you set F1-11 to 4 on the operation panel or F-7 to 2 on the keypad, all leveling adjustment parameters are reserved.

2. When the re-leveling function is used, the leveling adjustment function is automatically shielded and cannot be used.

Group FF: Factory Parameters

Group FP: User Parameters

Function Code	Parameter Name	Setting Range	Default	Unit	Property
FP-00	User password	0–65535	0	-	☆

It is used to set the user password.

If it is set to any non-zero number, the password protection function is enabled. After a password has been set and taken effect, you must enter the correct password in order to enter the menu. If the entered password is incorrect, you cannot view or modify parameters.

If FP-00 is set to 00000, the previously set user password is cleared, and the password protection function is disabled.

Remember the password that you set. If the password is set incorrectly or forgotten, contact Monarch to replace the control board.

Function Code	Parameter Name	Setting Range	Default	Unit	Property
FP-01	Parameter update	0–2	0	-	★

It is used to set processing on the parameters.

The values are as follows:

- 0: No operation
- 1: Restore default settings
- 2: Clear fault records

If you set this parameter to 1 (Restore default settings), all parameters except group F1 are restored to the default settings. Be cautious with this setting.

Function Code	Parameter Name	Setting Range	Default	Unit	Property
FP-02	User-defined parameter display	0: Invalid 1: Valid	0	-	★

It is used to set whether to display the parameters that are modified.

When it is set to 1, the parameters that are different from the default setting are displayed.



Troubleshooting

Chapter 8 Troubleshooting

8.1 Maintenance

8.1.1 Routine Maintenance

The influence of the ambient temperature, humidity, dust and vibration will cause the aging of the components inside the controller, which may cause potential faults or reduce the service life of the controller. Therefore, it is necessary to carry out routine and periodic maintenance.

Routine maintenance involves checking:

- Whether abnormal noise exists during motor running
- Whether the motor vibrates excessively
- Whether the installation environment of the controller changes
- Whether the cooling fan works properly
- Whether the controller overheats

Routine cleaning involves:

- Keep the controller clean all the time.
- Remove the dust, especially metal powder on the surface of the controller, to prevent the dust from entering the controller.
- Clear the oil stain on the cooling fan of the controller.

8.1.2 Periodic Inspection

Perform periodic inspection on the items that are difficult to check during running. Periodic inspection involves:

- Check and clean the air filter periodically.
- Check whether the screws become loose.
- Check whether the controller is corroded.
- Check whether the wiring terminals have arc signs.
- Carry out the main circuit insulation test.

Note

Before measuring the insulating resistance with megameter (500 VDC megameter recommended), disconnect the main circuit from the controller. Do not use the insulating resistance meter to test the insulation of the control circuit. The high voltage test need not be performed again because it has been completed before delivery.

8.1.3 Replacement of Vulnerable Components

Vulnerable components of the controller include the cooling fan and filter electrolytic capacitor. Their service life is related to the operating environment and maintenance.

The service life of the two components is listed in the following table.

Table 8-1 Service life of cooling fan and filter electrolytic capacitor

Component	Service Life	Possible Damage Cause	Judging Criteria
Fan	2 to 3 years	<ul style="list-style-type: none"> Bearing worn Blade aging 	<ul style="list-style-type: none"> Check whether there is crack on the blade. Check whether there is abnormal vibration noise upon startup.
Electrolytic capacitor	4 to 5 years	<ul style="list-style-type: none"> Input power supply in poor quality High ambient temperature Frequent load jumping Electrolytic aging 	<ul style="list-style-type: none"> Check whether there is liquid leakage. Check whether the safety valve has projected. Measure the static capacitance. Measure the insulating resistance.

The service life is obtained based on the following conditions:

- Ambient temperature: average 30°C per year
- Load rate: below 80%
- Running time: less than 20 hours per day

8.1.4 Storage of the Controller

For storage of the controller, pay attention to the following two aspects:

- Pack the controller with the original packing box provided by Monarch.
- Long-term storage degrades the electrolytic capacitor. Thus, the controller must be energized once every 2 years, each time lasting at least 5 hours. The input voltage must be increased slowly to the rated value with the regulator.

8.2 Description of Fault Levels

The NICE3000^{new} has almost 60 pieces of alarm information and protective functions. It monitors various input signals, running conditions and feedback signals. If a fault occurs, the system implements the relevant protective function and displays the fault code.

The controller is a complicated electronic control system and the displayed fault information is graded into five levels according to the severity. The faults of different levels are handled according to the following table.

Table 8-2 Fault levels

Category	Action	Remarks
Level 1	<ol style="list-style-type: none"> 1. Display the fault code. 2. Output the fault relay action command. 	1A. The elevator running is not affected on any condition.
Level 2	<ol style="list-style-type: none"> 1. Display fault code. 2. Output the fault relay action command. 3. Continue normal running of the elevator. 	2A. The parallel/group control I function is disabled.
		2B. The door pre-open/re-leveling function is disabled.
Level 3	<ol style="list-style-type: none"> 1. Display the fault code. 2. Output the fault relay action command. 3. Stop output and apply the brake immediately after stop. 	3A. In low-speed running, the elevator stops at special deceleration rate, and cannot restart.
		3B. In low-speed running, the elevator does not stop. In normal-speed running, the elevator stops, and then can start running at low speed after a delay of 3s.
Level 4	<ol style="list-style-type: none"> 1. Display the fault code. 2. Output the fault relay action command. 3. In distance control, the elevator decelerates to stop and cannot run again. 	4A. In low-speed running, the elevator stops under special deceleration rate, and cannot restart.
		4B. In low-speed running, the elevator does not stop. In normal-speed running, the elevator stops, and then can start running at low speed after a delay of 3s.
		4C. In low-speed running, the elevator does not stop. In normal-speed running, the elevator stops, and then can start running at low speed after a delay of 3s.
Level 5	<ol style="list-style-type: none"> 1. Display the fault code. 2. Output the fault relay action command. 3. The elevator stops immediately. 	5A. In low-speed running, the elevator stops immediately and cannot restart.
		5B. In low-speed running, the elevator does not stop. In normal-speed running, the elevator stops, and then can start running at low speed after a delay of 3s.

Note

- A, B, and C are fault sub-category.
- Low-speed running involves inspection, emergency evacuation, shaft auto-tuning, re-leveling, motor auto-tuning, base floor detection, and running in operation panel control.
- Normal-speed running involves automatic running, returning to base floor in fire emergency state, firefighter operation, attendant operation, elevator lock, and elevator parking.

8.3 Fault Information and Troubleshooting

If an alarm is reported, the system performs corresponding processing based on the fault level. You can handle the fault according to the possible causes described in the following table.

Table 8-3 Fault codes and troubleshooting

Fault Code	Name	Possible Causes	Solution	Level
Err02	Over-current during acceleration	<ul style="list-style-type: none"> • The main circuit output is grounded or short circuited. • Motor auto-tuning is performed improperly. • The load is too heavy. • The encoder signal is incorrect. • The UPS running feedback signal is incorrect. 	<ul style="list-style-type: none"> • Check whether the RUN contactor at the controller output side is normal. • Check: <ul style="list-style-type: none"> - Whether the power cable jacket is damaged - Whether the power cable is possibly short circuited to ground - Whether the power cable is connected reliably • Check the insulation of motor power terminals, and check whether the motor winding is short-circuited or grounded. 	5A
Err03	Over-current during deceleration	<ul style="list-style-type: none"> • The main circuit output is grounded or short circuited. • Motor auto-tuning is performed improperly. • The load is too heavy. • The deceleration rate is too short. • The encoder signal is incorrect. 	<ul style="list-style-type: none"> • Check whether shorting PMSM stator causes controller output short circuit. • Check whether motor parameters comply with the nameplate. • Perform motor auto-tuning again. • Check whether the brake keeps released before the fault occurs and whether the brake is stuck mechanically. • Check whether the balance coefficient is correct. • Check whether the encoder wirings are correct. For asynchronous motor, perform SVC and compare the current to judge whether the encoder works properly. <p>(To be continued)</p>	5A

Fault Code	Name	Possible Causes	Solution	Level
Err04	Over-current at constant speed	<ul style="list-style-type: none"> • The main circuit output is grounded or short circuited. • Motor auto-tuning is performed properly. • The load is too heavy. • The encoder is seriously interfered with. 	<ul style="list-style-type: none"> • Check: <ul style="list-style-type: none"> - Whether encoder pulses per revolution (PPR) is set correctly - Whether the encoder signal is interfered with - Whether the encoder cable runs through the duct independently - Whether the cable is too long - Whether the shield is grounded at one end • Check: <ul style="list-style-type: none"> - Whether the encoder is installed reliably - Whether the rotating shaft is connected to the motor shaft reliably - Whether the encoder is stable during normal-speed running • Check whether UPS feedback is valid in the non-UPS running state (Err02). • Check whether the acceleration/deceleration rate is too high (Err02, Err03). <p>(End)</p>	5A

Fault Code	Name	Possible Causes	Solution	Level
Err05	Over-voltage during acceleration	<ul style="list-style-type: none"> • The input voltage is too high. • The regeneration power of the motor is too high. • The braking resistance is too large, or the braking unit fails. • The acceleration rate is too short. 	<ul style="list-style-type: none"> • Adjust the input voltage. Observe whether the bus voltage is normal and whether it rises too quickly during running. • Check for the balance coefficient. • Select a proper braking resistor and check whether the resistance is too large based on the recommended braking resistance table in chapter 3. 	5A
Err06	Over-voltage during deceleration	<ul style="list-style-type: none"> • The input voltage is too high. • The braking resistance is too large, or the braking unit fails. • The deceleration rate is too short. 	<ul style="list-style-type: none"> • Check: <ul style="list-style-type: none"> - Whether the cable connecting the braking resistor is damaged 	5A
Err07	Over-voltage at constant speed	<ul style="list-style-type: none"> • The input voltage is too high. • The braking resistance is too large, or the braking unit fails. 	<ul style="list-style-type: none"> - Whether the cooper wire touches the ground - Whether the connection is reliable 	5A
Err08	Maintenance notification period reached	The elevator is not maintained within the notification period.	<ul style="list-style-type: none"> • Power-off and maintain the elevator. • Disable the maintenance notification function by setting F9-13 to 0. • Contact the agent or Monarch. 	5A
Err09	Under-voltage	<ul style="list-style-type: none"> • Instantaneous power failure occurs on the input power supply. • The input voltage is too low. • The drive control board fails. 	<ul style="list-style-type: none"> • Eliminate external power supply faults and check whether the power fails during running. • Check whether the wiring of all power input cables is secure. • Contact the agent or Monarch. 	5A

Fault Code	Name	Possible Causes	Solution	Level
Err10	Controller overload	<ul style="list-style-type: none"> • The brake circuit is abnormal. • The load is too heavy. • The encoder feedback signal is abnormal. • The motor parameters are incorrect. • A fault occurs on the motor power cables. 	<ul style="list-style-type: none"> • Check the brake circuit and power input. • Reduce the load. • Check whether the encoder feedback signal and setting are correct, and whether the initial angle of the encoder for the PMSM is correct. • Check the motor parameter setting and perform motor auto-tuning. • Check the power cables of the motor (refer to the solution of Err02). 	4A
Err11	Motor overload	<ul style="list-style-type: none"> • FC-02 is set improperly. • The brake circuit is abnormal. • The load is too heavy. 	<ul style="list-style-type: none"> • Adjust the parameter (FC-02 can be set to the default value). • Refer to the solution of Err10. 	3A
Err12	Power supply phase loss	<ul style="list-style-type: none"> • The power input phases are not symmetric. • The drive control board fails. 	<ul style="list-style-type: none"> • Check whether the three phases of power supply are balanced and whether the power voltage is normal. If not, adjust the power input. • Contact the agent or Monarch. 	4A
Err13	Power output phase loss	<ul style="list-style-type: none"> • The output wiring of the main circuit is loose. • The motor is damaged. 	<ul style="list-style-type: none"> • Check the wiring. • Check whether the contactor on the output side is normal. • Eliminate the motor fault. 	4A
Err14	Module overheat	<ul style="list-style-type: none"> • The ambient temperature is too high. • The fan is damaged. • The air filter is blocked. 	<ul style="list-style-type: none"> • Lower the ambient temperature. • Clear the air filter. • Replace the damaged fan. • Check whether the installation clearance of the controller satisfies the requirement. 	5A
Err15	Output abnormal	<ul style="list-style-type: none"> • Braking short-circuit occurs on the output side. • The U, V, W output is abnormal. 	<ul style="list-style-type: none"> • Check wiring of the braking resistor and braking unit is correct, without short-circuit. • Check whether the main contactor works properly. • Contact the agent or Monarch. 	5A

Fault Code	Name	Possible Causes	Solution	Level
Err16	Current control fault	<p>The excitation current deviation is too large.</p> <p>The torque current deviation is too large.</p> <p>The torque limit is exceeded for a very long time.</p>	<ul style="list-style-type: none"> • Check the circuit of the encoder. • The output MCCB becomes OFF. • The values of the current loop parameters are too small. • Perform motor auto-tuning again if the zero-point position is incorrect. • Reduce the load if it too heavy. 	5A
Err17	Reference signal of the encoder incorrect	<p>The deviation between the Z signal position and the absolute position is too large.</p> <p>The deviation between the absolute position angle and the accumulative angle is too large.</p>	<ul style="list-style-type: none"> • Check whether the encoder runs properly. • Check whether the encoder wiring is correct and reliable. • Check whether the PG card wiring is correct. • Check whether the grounding of the control cabinet and the motor is normal. 	5A
Err18	Current detection fault	The drive control board fails.	Contact the agent or Monarch.	5A
Err19	Motor auto-tuning fault	<p>The motor cannot rotate properly.</p> <p>The motor auto-tuning times out.</p> <p>The encoder for the PMSM fails.</p>	<ul style="list-style-type: none"> • Enter the motor parameters correctly. • Check the motor wiring and whether phase loss occurs on the contactor at the output side. • Check the encoder wiring and ensure that the encoder PPR is set properly. • Check whether the brake keeps released during no-load auto-tuning. • Check whether the inspection button is released before the PMSM with-load auto-tuning is finished. 	5A

Fault Code	Name	Possible Causes	Solution	Level
Err20	Speed feedback incorrect	<p>1: AB signals are lost during auto-tuning.</p> <p>3: The phase sequence of the motor is incorrect.</p> <p>4: Z signal cannot be detected during auto-tuning.</p> <p>5: The CD signal cables of the SIN/COS encoder break.</p> <p>7: The UVW cables of the UVW encoder break.</p> <p>8: The deviation between the absolute position angle and the cumulative angle is too large.</p> <p>9: Overspeed occurs or the speed deviation is too large.</p> <p>10/11: AB signals or CD signals of the SIN/COS encoder are interfered with.</p> <p>12: The detected speed is 0 at torque limit.</p> <p>13: AB signals are lost during running.</p> <p>14: Z signal is lost during running.</p> <p>19: The AB analog signal cables break during low-speed running.</p> <p>55: CD signal error or serious Z signal interference occurs during auto-tuning.</p>	<p>3: Exchange any two phases of the motor UVW cables.</p> <p>1, 4, 5, 7, 8, 10, 11, 13, 14, 19: Check that all signal cable wiring of the encoder is correct and secure.</p> <p>9: Check that the setting of F1-00, F1-12, and F1-25 for the synchronous motor is correct.</p> <p>12: Check that there is no mechanical stuck and that the brake has been released during running.</p> <p>55: Check that the grounding is reliable and eliminate interference problems.</p>	5A
Err22	Leveling signal abnormal	<p>101: The leveling signal is active during floor switchover.</p> <p>102: The falling edge of the leveling signal is not detected during elevator startup and floor switchover.</p> <p>103: The leveling position deviation is too large in elevator auto-running state.</p>	<p>101, 102:</p> <ul style="list-style-type: none"> • Check whether the leveling and door zone sensors work properly. • Check the installation verticality and depth of the leveling plates. • Check the leveling signal input points of the MCB. <p>103: Check whether the steel rope slips.</p>	1A

Fault Code	Name	Possible Causes	Solution	Level
Err24	RTC clock fault	101: The RTC clock information of the MCB is abnormal.	101: <ul style="list-style-type: none"> Replace the clock battery. Replace the MCB. 	3B
Err25	Storage data abnormal	101, 102: The storage data of the MCB is abnormal.	101, 102: Contact the agent or Monarch.	4A
Err26	Earthquake signal	101: The earthquake signal is active and the duration exceeds 2s.	101: Check that the earthquake signal is consistent with the parameter setting (NC, NO) of the MCB.	3B
Err29	Shorting PMSM stator feedback abnormal	101: The shorting PMSM stator feedback is abnormal.	101: <ul style="list-style-type: none"> Check that the state (NO, NC) of the feedback contact on the contactor is correct. Check that the contactor and corresponding feedback contact act correctly. Check the coil circuit of the shorting PMSM stator contactor. 	5A
Err30	Elevator position abnormal	101, 102: In the normal-speed running or re-leveling running mode, the running time is smaller than the smaller of F9-02 and (FA-38 + 10), but the leveling signal has no change.	101, 102: <ul style="list-style-type: none"> Check whether the leveling signal cables are connected reliably and whether the signal copper wires may touch the ground or be short circuited with other signal cables. Check whether the distance between two floors is too large, causing too long re-leveling running time. Check whether signal loss exists in the encoder circuits. 	4A

Fault Code	Name	Possible Causes	Solution	Level
Err33	Elevator speed abnormal	101: The detected running speed during normal-speed running exceeds the limit. 102: The speed exceeds the limit during inspection or shaft auto-tuning. 103: The speed exceeds the limit in shorting stator braking mode. 104: The speed exceeds the limit during emergency running. 105: The emergency running time protection function is enabled (set in Bit8 of F6-45), and the running time exceeds 50s, causing the timeout fault.	101: <ul style="list-style-type: none"> • Check whether the encoder is used properly. • Check the setting of motor nameplate parameters. Perform motor auto-tuning again. 102: Attempt to decrease the inspection speed or perform motor auto-tuning again. 103: Check whether the shorting PMSM stator function is enabled. 104, 105: <ul style="list-style-type: none"> • Check whether the emergency power capacity meets the requirements. • Check whether the emergency running speed is set properly. 	5A
Err34	Logic fault	Logic of the MCB is abnormal.	Contact the agent or Monarch.	5A

Fault Code	Name	Possible Causes	Solution	Level
Err35	Shaft auto-tuning data abnormal	<p>101: When shaft auto-tuning is started, the elevator is not at the bottom floor or the down slow-down is invalid,</p> <p>102: The system is not in the inspection state when shaft auto-tuning is performed.</p> <p>103: It is judged upon power-on that shaft auto-tuning is not performed.</p> <p>104: In distance control mode, it is judged at running startup that shaft auto-tuning is not performed.</p> <p>105: The elevator running direction and the pulse change are inconsistent.</p> <p>106, 107, 109, 114: The plate pulse length sensed at up/down leveling is abnormal.</p> <p>108, 110: No leveling signal is received within 45s continuous running.</p> <p>111, 115: The stored floor height is smaller than 50 cm.</p> <p>112: The floor when auto-tuning is completed is not the top floor.</p> <p>113: The pulse check is abnormal.</p>	<p>101: Check that the next slow-down switch is valid, and that F4-01 (Current floor) is set to 1.</p> <p>102: Check that the inspection switch is in inspection state.</p> <p>103, 104: Perform shaft auto-tuning.</p> <p>105: Check whether the elevator running direction is consistent with the pulse change in F4-03: F4-03 increases in up direction and decreases in down direction. If not, change the value of F2-10 to ensure consistency.</p> <p>106, 107, 109, 114:</p> <ul style="list-style-type: none"> • Check that NO/NC setting of the leveling sensor is set correctly • Check whether the leveling plates are inserted properly and whether there is strong power interference if the leveling sensor signal blinks. • Check whether the leveling plate is too long for the asynchronous motor. <p>108, 110: Check whether the running times out: No leveling signal is received when the running time exceeds F9-02.</p> <p>111, 115: Enable the super short floor function if the floor distance is less than 50 cm. If the floor distance is normal, check installation of the leveling plate for this floor and check the sensor.</p> <p>112: Check whether the setting of F6-00 (Top floor of the elevator) is smaller than the actual condition.</p> <p>113: Check whether the signal of the leveling sensor is normal. Perform shaft auto-tuning again.</p>	4C

Fault Code	Name	Possible Causes	Solution	Level
Err36	RUN contactor feedback abnormal	101: The feedback of the RUN contactor is active, but the contactor has no output. 102: The controller outputs the RUN signal but receives no RUN feedback. 103: The startup current of the asynchronous motor is too small. 104: When both feedback signals of the RUN contactor are enabled, their states are inconsistent.	101, 102, 104: <ul style="list-style-type: none"> • Check whether the feedback contact of the contactor acts properly. • Check the signal feature (NO, NC) of the feedback contact. 103: <ul style="list-style-type: none"> • Check whether the output cables UVW of the controller are connected properly. • Check whether the control circuit of the RUN contactor coil is normal. 	5A
Err37	Brake contactor feedback abnormal	101: The output of the brake contactor is inconsistent with the feedback. 102: When both feedback signals of the brake contactor are enabled, their states are inconsistent. 103: The output of the brake contactor is inconsistent with the feedback 2. 104: When both feedback 2 signals of the brake contactor are enabled, their states are inconsistent.	101 to 104: <ul style="list-style-type: none"> • Check whether the brake coil and feedback contact are correct. • Check the signal feature (NO, NC) of the feedback contact. • Check whether the control circuit of the brake contactor coil is normal. 	5A
Err38	Encoder signal abnormal	101: Pulse signal change in F4-03 does not change within the time threshold in of F1-13. 102: The running direction and pulse direction are inconsistent.	101, 102: <ul style="list-style-type: none"> • Check whether the encoder is used correctly. • Exchange phases A and B of the encoder. • Check whether the system and signal cables are grounded reliably. • Check whether cabling between the encoder and the PG card is correct. 	5A
Err39	Motor overheat	101: The motor overheat relay input remains valid for a certain time.	101: <ul style="list-style-type: none"> • Check whether the thermal protection relay is normal. • Check whether the motor is used properly and whether it is damaged. • Improve cooling conditions of the motor. 	3A

Fault Code	Name	Possible Causes	Solution	Level
Err40	Elevator running reached	The set elevator running time is reached.	Check the related parameter, or contact the agent or Monarch.	4B
Err41	Safety circuit disconnected	101: The safety circuit signal becomes OFF.	101: <ul style="list-style-type: none"> • Check the safety circuit switches and their states. • Check whether the external power supply is normal. • Check whether the safety circuit contactor acts properly. • Confirm the signal feature (NO, NC) of the feedback contact of the safety circuit contactor. 	5A
Err42	Door lock disconnected during running	101: The door lock circuit feedback is invalid during the elevator running.	101: <ul style="list-style-type: none"> • Check whether the hall door lock and the car door lock are in good contact. • Check whether the door lock contactor acts properly. • Check the signal feature (NO, NC) of the feedback contact on the door lock contactor. • Check whether the external power supply is normal. 	5A
Err43	Up limit signal abnormal	101: The up limit switch acts when the elevator is running in the up direction.	101: <ul style="list-style-type: none"> • Check the signal feature (NO, NC) of the up limit switch. • Check whether the up limit switch is in good contact. • Check whether the limit switch is installed at a relatively low position and acts even when the elevator arrives at the terminal floor normally. 	4C
Err44	Down limit signal abnormal	101: The down limit switch acts when the elevator is running in the down direction.	101: <ul style="list-style-type: none"> • Check the signal feature (NO, NC) of the down limit switch. • Check whether the down limit switch is in good contact. • Check whether the limit switch is installed at a relatively high position and thus acts even when the elevator arrives at the terminal floor normally. 	4C

Fault Code	Name	Possible Causes	Solution	Level
Err45	Slow-down switch position abnormal	101: The down slow-down distance is insufficient during shaft auto-tuning. 102: The up slow-down distance is insufficient during shaft auto-tuning. 103: The slow-down position is abnormal during normal running. 104, 105: The elevator speed exceeds the maximum speed when slow-down 1 is enabled.	101 to 103: <ul style="list-style-type: none"> • Check whether the up slow-down 1 and the down slow-down 1 are in good contact. • Check the signal feature (NO, NC) of the up slow-down 1 and the down slow-down 1. 104, 105: Ensure that the obtained slow-down distance satisfies the slow-down requirement at the elevator speed.	4B
Err46	Re-leveling abnormal	101: The leveling signal is inactive during re-leveling. 102: The re-leveling running speed exceeds 0.1 m/s. 103: At startup of normal-speed running, the re-leveling state is valid and there is shorting door lock circuit feedback. 104: During re-leveling, no shorting door lock circuit feedback or door lock signal is received 2s after shorting door lock circuit output.	101: Check whether the leveling signal is normal. 102: Check whether the encoder is used properly. 103, 104: <ul style="list-style-type: none"> • Check whether the signal of the leveling sensor is normal. • Check the signal feature (NO, NC) of the feedback contact on the shorting door lock circuit contactor, and check the relay and wiring of the SCB-A board. 	2B
Err47	Shorting door lock circuit contactor abnormal	101: During re-leveling or pre-open running, the shorting door lock circuit contactor outputs for continuous 2s, but the feedback is invalid and the door lock is disconnected. 102: During re-leveling or pre-open running, the shorting door lock circuit contactor has no output, but the feedback is valid for continuous 2s. 103: During re-leveling or pre-open running, the output time of the shorting door lock circuit contactor is larger than 15s.	101, 102: <ul style="list-style-type: none"> • Check the signal feature (NO, NC) of the feedback contact on the shorting door lock circuit contactor. • Check whether the shorting door lock circuit contactor acts properly. 103: <ul style="list-style-type: none"> • Check whether the leveling and re-leveling signals are normal. • Check whether the re-leveling speed is set too low. 	2B

Fault Code	Name	Possible Causes	Solution	Level
Err48	Door open fault	101: The consecutive times that the door does not open to the limit reaches the setting in Fb-13.	101: <ul style="list-style-type: none"> • Check whether the door machine system works properly. • Check whether the CTB is normal. • Check whether the door open limit signal is normal. 	5A
Err49	Door close fault	101: The consecutive times that the door does not open to the limit reaches the setting in Fb-13.	101: <ul style="list-style-type: none"> • Check whether the door machine system works properly. • Check whether the CTB is normal. • Check whether the door lock acts properly. 	5A
Err50	Consecutive loss of leveling signal	Leveling signal stuck or loss occurs for three consecutive times (Err22 is reported for three consecutive times).	<ul style="list-style-type: none"> • Check whether the leveling and door zone sensors work properly. • Check the installation verticality and depth of the leveling plates. • Check the leveling signal input points of the MCB. Check whether the steel rope slips. 	5A
Err51	CAN communication abnormal	101: Feedback data of CANbus communication with the CTB remains incorrect.	101: <ul style="list-style-type: none"> • Check the communication cable connection. • Check the power supply of the CTB. • Check whether the 24 V power supply of the controller is normal. • Check whether strong-power interference on communication exists. 	1A

Fault Code	Name	Possible Causes	Solution	Level
Err52	HCB communication abnormal	101: Feedback data of Modbus communication with the HCB remains incorrect.	101: <ul style="list-style-type: none"> • Check the communication cable connection. • Check whether the 24 V power supply of the controller is normal. • Check whether the HCB addresses are repeated. • Check whether strong-power interference on communication exists. 	1A
Err53	Door lock fault	101: The door lock feedback signal remains active for more than 3s during door open. 102: The multiple door lock feedback signal states are inconsistent for more than 2s.	101: <ul style="list-style-type: none"> • Check whether the door lock circuit is normal. • Check whether the feedback contact of the door lock contactor acts properly. • Check whether the system receives the door open limit signal when the door lock signal is valid. 102: Check whether when the hall door lock signal and the car door lock signal are detected separately, the detected states of the hall door locks and car door lock are inconsistent.	5A
Err54	Overcurrent at inspection startup	The current at startup for inspection exceeds 110% of the rated current.	<ul style="list-style-type: none"> • Reduce the load • Change Bit1 of FC-00 to 1 to cancel the startup current detection function. 	5A
Err55	Stop at another landing floor	101: During automatic running of the elevator, the door open limit is not achieved at the present floor.	101: Check the door open limit signal at the present floor.	1A
Err57	Serial peripheral interface (SPI) communication abnormal	101, 102: The SPI communication is abnormal. No correct data is received with 2s of DSP communication. 103: The MCB does not match the AC drive.	101, 102: Check the wiring between the control board and the drive board. 103: Contact the agent or Monarch.	5A

Fault Code	Name	Possible Causes	Solution	Level
Err58	Shaft position switches abnormal	101: The up slow-down and down slow-down are disconnected simultaneously. 102: The up limit feedback and down limit feedback are disconnected simultaneously.	101, 102: <ul style="list-style-type: none"> • Check whether the states (NO, NC) of the slow-down switches and limit switches are consistent with the parameter setting of the MCB. • Check whether malfunction of the slow-down switches and limit switches exists. 	4B
Err62	Analog input cable broken	The analog input cable of the CTB or the MCB is broken.	<ul style="list-style-type: none"> • Check whether F5-36 is set correctly. • Check whether the analog input cable of the CTB or MCB is connected incorrectly or broken. 	1A

Note

- Fault Err41 is not recorded in the elevator stop state.
 - Fault Err42 is reset automatically when the door lock circuit is shorted or 1s after the fault occurs in the door zone.
 - If faults Err51 and Err52 persist, they are recorded once every one hour.
 - Except the fault code and level, the number (such as 1, 101) indicates the fault subcode.
-
-



EMC

Chapter 9 EMC

9.1 Definition of Terms

1. EMC

Electromagnetic compatibility (EMC) describes the ability of electronic and electrical devices or systems to work properly in the electromagnetic environment and not to generate electromagnetic interference that influences other local devices or systems.

In other words, EMC includes two aspects: The electromagnetic interference generated by a device or system must be restricted within a certain limit; the device or system must have sufficient immunity to the electromagnetic interference in the environment.

2. First environment

Environment that includes domestic premises, it also includes establishments directly connected without intermediate transformers to a low-voltage power supply network which supplies buildings used for domestic purposes

3. Second environment

Environment that includes all establishments other than those directly connected to a low-voltage power supply network which supplies buildings used for domestic purposes

4. Category C1 Controller

Power Drive System (PDS) of rated voltage less than 1 000 V, intended for use in the first environment

5. Category C2 Controller

PDS of rated voltage less than 1 000 V, which is neither a plug in device nor a movable device and, when used in the first environment, is intended to be installed and commissioned only by a professional

6. Category C3 Controller

PDS of rated voltage less than 1 000 V, intended for use in the second environment and not intended for use in the first environment

7. Category C4 Controller

PDS of rated voltage equal to or above 1 000 V, or rated current equal to or above 400 A, or intended for use in complex systems in the second environment

9.2 Introduction to EMC Standard

9.2.1 Installation Environment

The system manufacturer using the controller is responsible for compliance of the system with the European EMC directive. Based on the application of the system, the integrator must ensure that the system complies with standard EN 61800-3: 2004 Category C2, C3 or C4.

The system (machinery or appliance) installed with the controller must also have the CE mark. The system integrator is responsible for compliance of the system with the EMC directive and standard EN 61800-3: 2004 Category C2.



If applied in the first environment, the controller may generate radio interference. Besides the CE compliance described in this chapter, users must take measures to avoid such interference, if necessary.

9.2.2 Requirements on Satisfying the EMC Directive

1. The controller requires an external EMC filter. The recommended filter models are listed in Table 9-1. The cable connecting the filter and the controller should be as short as possible and be not longer than 30 cm. Furthermore, install the filter and the controller on the same metal plate, and ensure that the grounding terminal of the controller and the grounding point of the filter are in good contact with the metal plate.
2. Select the motor and the control cable according to the description of the cable in section 9.4.
3. Install the controller and arrange the cables according to the cabling and grounding in section 9.4.
4. Install an AC reactor to restrict the current harmonics. For the recommended models, see Table 9-2.

9.3 Selection of Peripheral EMC Devices

9.3.1 Installation of EMC Input Filter on Power Input Side

An EMC filter installed between the controller and the power supply can not only restrict the interference of electromagnetic noise in the surrounding environment on the controller, but also prevents the interference from the controller on the surrounding equipment.

The NICE3000^{new} controller satisfies the requirements of category C2 only with an EMC filter installed on the power input side. The installation precautions are as follows:

- Strictly comply with the ratings when using the EMC filter. The EMC filter is category I electric apparatus, and therefore, the metal housing ground of the filter should be in good contact with the metal ground of the installation cabinet on a large area, and requires good conductive continuity. Otherwise, it will result in electric shock or poor EMC effect.
- The grounds of the EMC filter and the PE conductor of the controller must be tied to the same common ground. Otherwise, the EMC effect will be affected seriously.
- The EMC filter should be installed as closely as possible to the power input side of the controller.

The following table lists the recommended manufacturers and models of EMC filters for the NICE3000^{new} controller. Select a proper one based on actual requirements.

Table 9-1 Recommended manufacturers and models of EMC filter

Controller Model	Power Capacity (kVA)	Rated Input Current (A)	AC Input Filter Model (Changzhou Jianli)	AC Input Filter Model (Schaffner)
Three-phase 380 V, range: -15% to 20%				
NICE-L-C-4002	4.0	6.5	DL-10EBK5	FN 3258-7-44
NICE-L-C-4003	5.9	10.5	DL-16EBK5	FN 3258-16-33
NICE-L-C-4005	8.9	14.8	DL-16EBK5	FN 3258-16-33
NICE-L-C-4007	11.0	20.5	DL-25EBK5	FN 3258-30-33
NICE-L-C-4011	17.0	29.0	DL-35EBK5	FN 3258-30-33
NICE-L-C-4015	21.0	36.0	DL-50EBK5	FN 3258-42-33
NICE-L-C-4018	24.0	41.0	DL-50EBK5	FN 3258-42-33
NICE-L-C-4022	30.0	49.5	DL-50EBK5	FN 3258-55-34
NICE-L-C-4030	40.0	62.0	DL-65EBK5	FN 3258-75-34
NICE-L-C-4037	57.0	77.0	DL-80EBK5	FN 3258-100-35
NICE-L-C-4045	69.0	93.0	DL-100EBK5	FN 3258-100-35
NICE-L-C-4055	85	113	DL-130EBK5	FN 3258-130-35
Three-phase 220 V, range: -15% to 20%				
NICE-L-C-2002	4.0	11.0	DL-16EBK5	FN 3258-7-44
NICE-L-C-2003	5.9	17.0	DL-25EBK5	FN 3258-7-44
220-NICE-L-C-4007	17.0	29.0	DL-35EBK5	FN 3258-7-44
220-NICE-L-C-4011	21.0	36.0	DL-50EBK5	FN 3258-16-33
220-NICE-L-C-4015	24.0	41.0	DL-50EBK5	FN 3258-16-33
220-NICE-L-C-4018	30.0	40.0	DL-50EBK5	FN 3258-30-33
220-NICE-L-C-4022	40.0	49.0	DL-50EBK5	FN 3258-30-33
220-NICE-L-C-4030	57.0	61.0	DL-65EBK5	FN 3258-42-33
Single-phase 220 V, range: -15% to 20%				
NICE-L-C-2002	2.3	13.2	DL-20TH1	FN 2090-20-06
NICE-L-C-2003	3.4	17.0	DL-20TH1	FN 2090-20-06
220-NICE-L-C-4007	9.8	29.0	DL-30TH1	FN 2090-30-08
220-NICE-L-C-4011	12.1	36.0	DL-40K3	Consult the manufacturer.
220-NICE-L-C-4015	13.9	41.0	DL-50T3	
220-NICE-L-C-4018	17.3	40.0	DL-50T3	
220-NICE-L-C-4022	23.1	49.0	DL-50T3	
220-NICE-L-C-4030	33.0	61.0	DL-70TH1	

9.3.2 Installation of AC Input Reactor on Power Input Side

An AC input reactor is installed to eliminate the harmonics of the input current. As an optional device, the reactor can be installed externally to meet strict requirements of an application environment for harmonics. The following table lists the recommended manufacturers and models of input reactors.

Table 9-2 Recommended manufacturers and models of AC input reactors

Controller Model	Power Capacity (kVA)	Rated Input Current (A)	AC Input Reactor Model (Inovance)
Three-phase 380 V, range: -15% to 20%			
NICE-L-C-4002	4.0	6.5	MD-ACL-7-4T-222-2%
NICE-L-C-4003	5.9	10.5	MD-ACL-10-4T-372-2%
NICE-L-C-4005	8.9	14.8	MD-ACL-15-4T-552-2%
NICE-L-C-4007	11.0	20.5	MD-ACL-30-4T-113-2%
NICE-L-C-4011	17.0	29.0	MD-ACL-30-4T-113-2%
NICE-L-C-4015	21.0	36.0	MD-ACL-40-4T-153-2%
NICE-L-C-4018	24.0	41.0	MD-ACL-50-4T-183-2%
NICE-L-C-4022	30.0	49.5	MD-ACL-50-4T-183-2%
NICE-L-C-4030	40.0	62.0	MD-ACL-80-4T-303-2%
NICE-L-C-4037	57.0	77.0	MD-ACL-80-4T-303-2%
NICE-L-C-4045	69.0	93.0	MD-ACL-120-4T-453-2%
NICE-L-C-4055	85	113	MD-ACL-120-4T-453-2%
Three-phase 220 V, range: -15% to 20%			
NICE-L-C-2002	4.0	11.0	MD-ACL-15-4T-222-2%
NICE-L-C-2003	5.9	17.0	MD-ACL-30-4T-222-2%
220-NICE-L-C-4007	17.0	29.0	MD-ACL-30-4T-113-2%
220-NICE-L-C-4011	21.0	36.0	MD-ACL-50-4T-113-2%
220-NICE-L-C-4015	24.0	41.0	MD-ACL-50-4T-153-2%
220-NICE-L-C-4018	30.0	40.0	MD-ACL-50-4T-183-2%
220-NICE-L-C-4022	40.0	49.0	MD-ACL-50-4T-183-2%
220-NICE-L-C-4030	57.0	61.0	MD-ACL-80-4T-303-2%

Controller Model	Power Capacity (kVA)	Rated Input Current (A)	AC Input Reactor Model (Inovance)
Single-phase 220 V, range: -15% to 20%			
NICE-L-C-2002	2.3	13.2	Consult the manufacturer.
NICE-L-C-2003	3.4	17.0	
220-NICE-L-C-4007	9.8	29.0	
220-NICE-L-C-4011	12.1	36.0	
220-NICE-L-C-4015	13.9	41.0	
220-NICE-L-C-4018	17.3	40.0	
220-NICE-L-C-4022	23.1	49.0	
220-NICE-L-C-4030	33.0	61.0	

9.4 Shielded Cable

9.4.1 Requirements for the Shielded Cable

The shielded cable must be used to satisfy the EMC requirements. Shielded cables are classified into three-conductor cable and four-conductor cable. If conductivity of the cable shield is not sufficient, add an independent PE cable, or use a four-conductor cable, of which one phase conductor is PE cable.

The three-conductor cable and four-conductor cable are shown in the following figure.

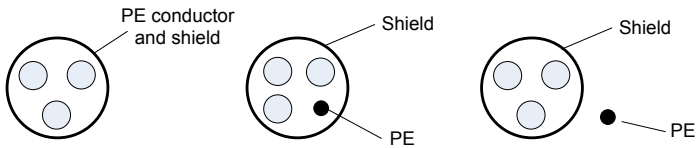

The motor cable and PE shielded conducting wire (twisted shielded) should be as short as possible to reduce electromagnetic radiation and external stray current and capacitive current of the cable.

To suppress emission and conduction of the radio frequency interference effectively, the shield of the shielded cable is copper braid. The braided density of the copper braid should be greater than 90% to enhance the shielding efficiency and conductivity, as shown in the following figure.

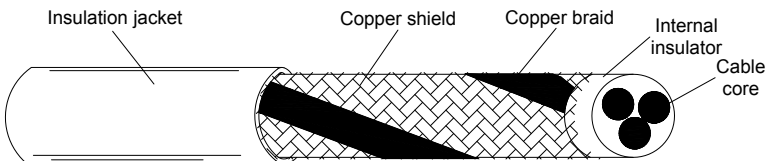

It is recommended that all control cables be shielded. The grounding area of the shielded cable should be as large as possible. A suggested method is to fix the shield on the metal plate using the metal cable clamp so as to achieve good contact, as shown in the following figure.

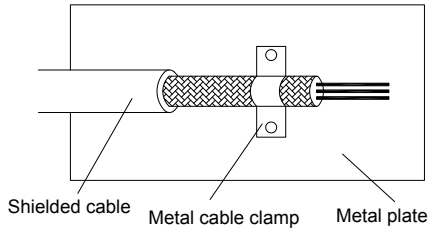

The following figure shows the grounding method of the shielded cable.

Figure 9-1 Grounding of the shielded cable

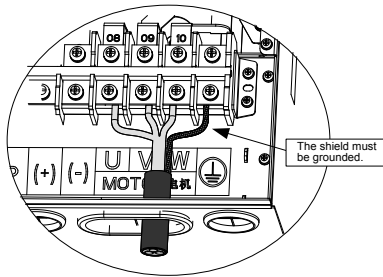

9.4.2 Installation Precautions of the Shielded Cable

- Symmetrical shielded cable is recommended. The four-conductor shielded cable can also be used as an input cable.
- The motor cable and PE shielded conducting wire (twisted shielded) should be as short as possible to reduce electromagnetic radiation and external stray current and capacitive current of the cable. If the motor cable is over 100 meters long, an output filter or reactor is required.
- It is recommended that all control cables be shielded.
- It is recommended that a shielded cable be used as the output power cable of the controller; the cable shield must be well grounded. For devices suffering from interference, shielded twisted pair (STP) cable is recommended as the lead wire and the cable shield must be well grounded.

9.4.3 Cabling Requirement

1. The motor cables must be laid far away from other cables, with recommended distance larger than 0.5 m. The motor cables of several controllers can be laid side by side.
2. It is recommended that the motor cables, power input cables and control cables be laid in different ducts. To avoid electromagnetic interference caused by rapid change of the output voltage of the controller, the motor cables and other cables must not be laid side by side for a long distance.
3. If the control cable must run across the power cable, make sure they are arranged at an angle of close to 90°. Other cables must not run across the controller.
4. The power input and output cables of the controller and weak-current signal cables (such as control cable) should be laid vertically (if possible) rather than in parallel.
5. The cable ducts must be in good connection and well grounded. Aluminium ducts can be used to improve electric potential.
6. The filter and controller should be connected to the cabinet properly, with spraying protection at the installation part and conductive metal in full contact.
7. The motor should be connected to the system (machinery or appliance) properly, with spraying protection at the installation part and conductive metal in full contact.

Figure 9-2 Cabling diagram

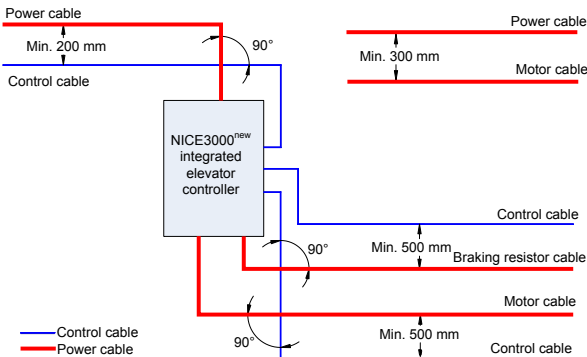

9.5 Solutions to Common EMC Interference Problems

The controller generates very strong interference. Although EMC measures are taken, the interference may still exist due to improper cabling or grounding during use. When the controller interferes with other devices, adopt the following solutions.

Interference Type	Solution
Leakage protection switch tripping	<ul style="list-style-type: none"> • Connect the motor housing to the PE of the controller. • Connect the PE of the controller to the PE of the mains power supply. • Add a safety capacitor to the power input cable. • Add magnetic rings to the input drive cable.
Controller interference during running	<ul style="list-style-type: none"> • Connect the motor housing to the PE of the controller. • Connect the PE of the controller to the PE of the mains voltage. • Add a safety capacitor to the power input cable and wind the cable with magnetic rings. • Add a safety capacitor to the interfered signal port or wind the signal cable with magnetic rings. • Connect the equipment to the common ground.
Communication interference	<ul style="list-style-type: none"> • Connect the motor housing to the PE of the controller. • Connect the PE of the controller to the PE of the mains voltage. • Add a safety capacitor to the power input cable and wind the cable with magnetic rings. • Add a matching resistor between the communication cable source and the load side. • Add a common grounding cable besides the communication cable. • Use a shielded cable as the communication cable and connect the cable shield to the common grounding point.
I/O interference	<ul style="list-style-type: none"> • Enlarge the capacitance at the low-speed DI. A maximum of 0.11 μF capacitance is suggested. • Enlarge the capacitance at the AI. A maximum of 0.22 μF is suggested.

Monarch Warranty Agreement

1. The warranty period of the product is 18 months from date of manufacturing. During the warranty period, if the product fails or is damaged under the condition of normal use by following the instructions, Inovance will be responsible for free maintenance.
2. Within the warranty period, maintenance will be charged for the damages caused by the following reasons:
 - a. Improper use or repair/modification without prior permission
 - b. Fire, flood, abnormal voltage, other disasters and secondary disaster
 - c. Hardware damage caused by dropping or transportation after procurement
 - d. Improper operation
 - e. Damage out of the equipment (for example, external device)
3. If there is any failure or damage to the product, please correctly fill out the Product Warranty Card in detail.
4. The maintenance fee is charged according to the latest Maintenance Price List of Monarch.
5. The Product Warranty Card is not re-issued. Please keep the card and present it to the maintenance personnel when asking for maintenance.
6. If there is any problem during the service, contact Monarch's agent or Monarch directly.
7. This agreement shall be interpreted by Suzhou MONARCH Control Technology Co., Ltd.

Service Department, Suzhou MONARCH Control Technology Co., Ltd.

Address: No.16, Youxiang Road, Yuexi Town, Wuzhong District, Suzhou, P.R.China

P.C.: 215104

Website: <http://www.szmctc.cn>

Monarch Product Warranty Card

Customer information	Address:	
	Company name:	Contact person:
	P.C.:	Tel. or Email:
Product information	Product model:	
	Series No. (Attach here):	
	Name of supplier:	
Failure information (eg. fault code)	(Maintenance time and content):	
	Maintenance person:	

MONARCH

NICE3000^{new}

Integrated Elevator Controller

MONARCH

Suzhou MONARCH Control Technology Co., Ltd.

Add. : No. 16, Youxiang Road, Yuexi Town, Wuzhong District, Suzhou 215104, P. R. China

Tel: +86-512 6879 5207

Fax: +86-512 6285 6720

<http://www.szmctc.com>